

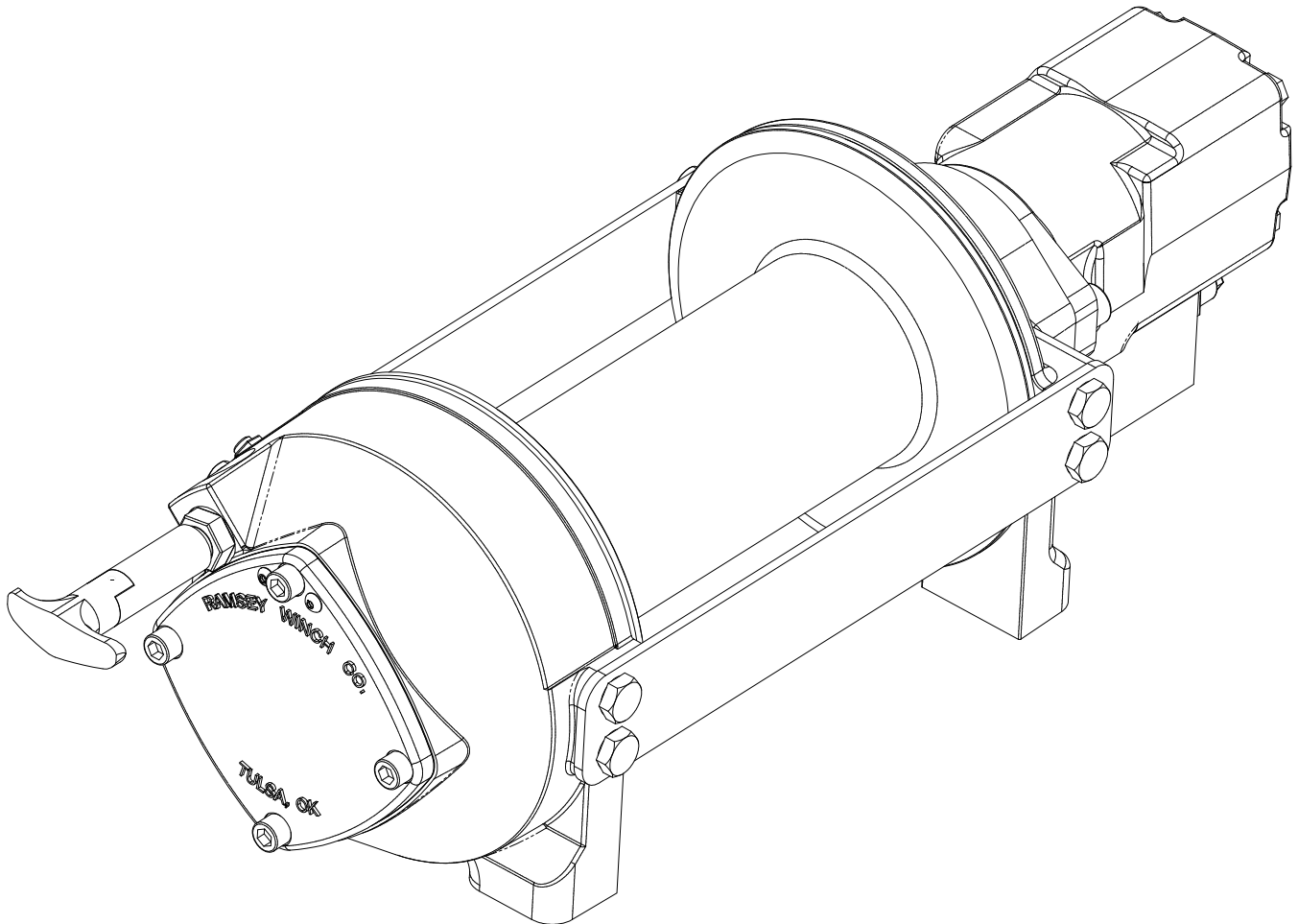

OPERATING, SERVICE AND MAINTENANCE MANUAL



MODEL HD-P10000 PLANETARY WINCH



CAUTION: READ AND UNDERSTAND THIS MANUAL BEFORE INSTALLATION AND OPERATION OF WINCH. SEE WARNINGS!

TABLE OF CONTENTS

INTRODUCTIONS	1
WARRANTY INFORMATION	1
SPECIFICATIONS	1
WARNINGS	1
WINCH MOUNTING	2
CABLE INSTALLATION	3
HYDRAULIC SYSTEM REQUIREMENTS	4
TYPICAL LAYOUT	4
PERFORMANCE CHARTS	4
OPERATION	5
MAINTENANCE	5
TROUBLE SHOOTING GUIDE	6
OVERHAUL INSTRUCTIONS	7-12
DIMENSIONAL DRAWINGS	14-15
PARTS LIST AND PARTS DRAWINGS	16-19
LIMITED WARRANTY	BACK COVER

PLEASE READ THIS MANUAL CAREFULLY

This manual contains useful ideas for obtaining the most efficient operation from your Ramsey Winch, and safety procedures one needs to know before operating a Ramsey Winch. Do not operate this winch until you have carefully read and understand the "WARNING" and "OPERATION" sections of this manual.

WARRANTY INFORMATION

Ramsey Winches are designed and built to exacting specifications. Great care and skill go into every winch we make. If the need should arise, warranty procedure is outlined on the back of your self-addressed postage paid warranty card. Please read and fill out the enclosed warranty card and send it to Ramsey Winch Company. If you have any problems with your winch, please follow instructions for prompt service on all warranty claims. Refer to back page for limited warranty.

SPECIFICATIONS*

Rated Line Pull (lbs.)	10,000
(Kg.)	4,530
Gear Reduction	5.1:1
Weight (without cable) HD-P10000 STD	87 lbs. (39.5 Kg)
HD-P10000 "Y"	82 lbs. (37.2 Kg)
LAYER OF CABLE	1 2 3 4
*Rated line pull lbs.	10,000 8,300 7,100 6200
per layer Kg.	4,530 3,760 3,220 2810

* Cable Capacity per Layer

HD-P10000 (STD. DRUM)	ft.	20	50	80	115
	m	6	15	24	35
HD-P10000 ("Y" DRUM)	ft.	15	30	55	75
	m	4	9	16	22
* Line Speed (at 15 GPM)	FPM	32	38	44	51
	MPM	9.8	11.6	13.4	15.5
* These specifications are based on recommended wire rope of 7/16" (11mm) EIPS cable and a 24.9 cu.in./Rev. motor.					

NOTE: The rated line pulls shown are for the winch only. Consult the wire rope manufacturer for wire rope ratings.

WARNINGS:

A MOTOR SPOOL (OPEN CENTER) DIRECTIONAL CONTROL VALVE IS REQUIRED FOR BRAKE OPERATION.

CLUTCH MUST BE FULLY ENGAGED BEFORE STARTING THE WINCH.

DO NOT DISENGAGE CLUTCH UNDER LOAD.

DO NOT LEAVE CLUTCH ENGAGED WHEN WINCH IS NOT IN USE.

STAY OUT FROM UNDER AND AWAY FROM RAISED LOADS.

STAND CLEAR OF CABLE WHILE PULLING. DO NOT TRY TO GUIDE CABLE.

DO NOT EXCEED MAXIMUM LINE PULL RATINGS SHOWN IN TABLE.

DO NOT USE WINCH TO LIFT, SUPPORT, OR OTHERWISE TRANSPORT PERSONNEL.

A MINIMUM OF 5 WRAPS OF CABLE AROUND THE DRUM BARREL IS NECESSARY TO HOLD THE LOAD. CABLE CLAMP (SETSCREW) IS NOT DESIGNED TO HOLD LOAD.

IN CAR CARRIER APPLICATIONS, AFTER PULLING VEHICLE ON CARRIER, BE SURE TO SECURE VEHICLE TO CARRIER BED. DO NOT MAINTAIN LOAD ON WINCH CABLE WHILE TRANSPORTING VEHICLE. DO NOT USE WINCH AS A TIEDOWN.

WHEN PULLING A HEAVY LOAD PLACE A BLANKET, JACKET, OR TARPAULIN OVER THE CABLE FIVE OR SIX FEET FROM THE HOOK.

AVOID CONDITIONS WHERE LOAD SHIFTS OR JERKS OCCUR, AS THEY MAY INDICATE A DANGEROUS SITUATION.

WINCH MOUNTING

ESSENTIAL MOUNTING INSTRUCTIONS TO MAINTAIN ALIGNMENT OF PLANETARY WINCH COMPONENTS:

It is most important that this winch be mounted securely so that the three major sections (the motor end, the cable drum, and the gear housing end) are properly aligned. Excessive bushing wear and difficulty in freespooling are usually symptoms of misalignment.

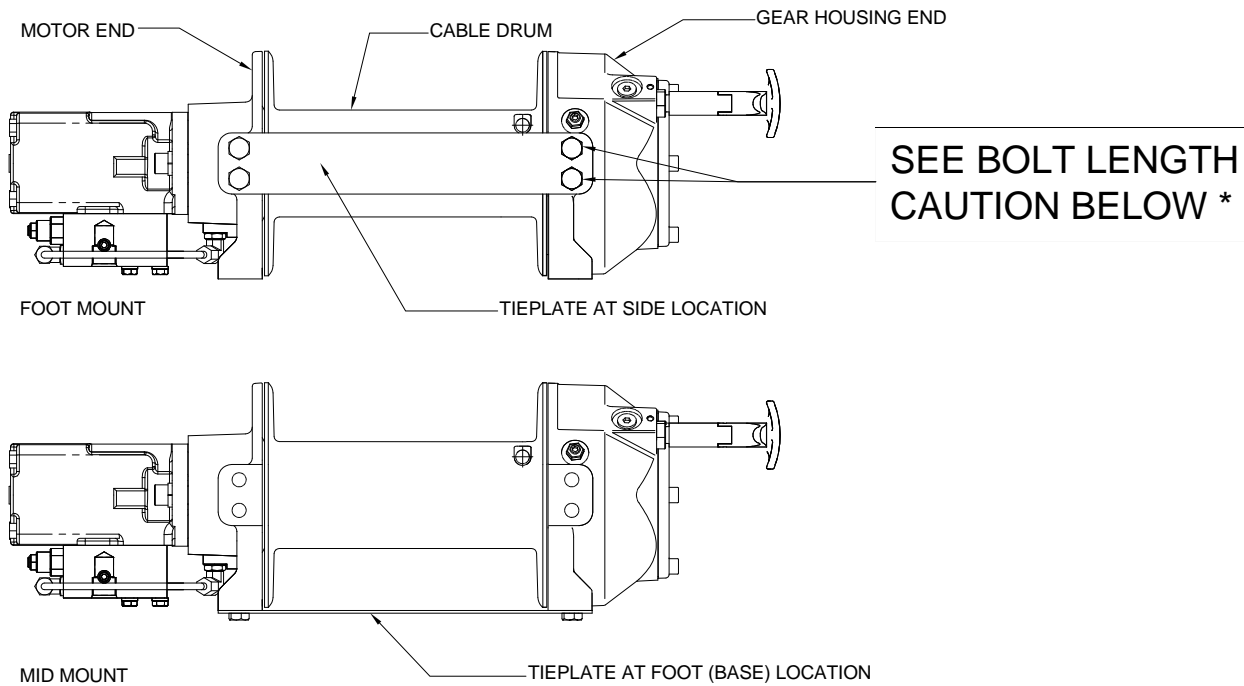

In the as-installed condition, if the winch is mid-mounted, then at least one tie-plate must be attached to the mounting feet at the bottom of the winch to maintain alignment. If the winch is foot mounted then at least one tie-plate must remain mounted at midpoint of winch to maintain alignment. It is always preferred to use BOTH tie-plates in the final installed configuration.

Angle Mounting Kit, P/N 251006 (for Std. Drum) or 251007 (for “Y” drum), is recommended for maximum ease in mounting the winch. The angle kit will allow the winch to be mounted in upright or midmount applications and will meet the criteria of serving as a solid and true mounting surface.

When mounting the winch with other than the recommended Ramsey Angle Kit, the mounting hole patterns described in the Dimensional drawings on pages 14-15 should be used. The mounting surface must be flat within .015 inch and sufficiently stiff to resist flexing. If a steel plate is used for foot mounting, it should be .750 inch thick. For this mounting application eight (8) 1/2-13NC x 1-1/2” long grade 5 capscrews with lockwashers will be needed to mount winch. Capscrews should be tightened to 55 ft-lb (75 Nm) torque.

NOTE: If angles or a steel plate are used in mounting winch, tie-plates provided with winch are to be attached to the remaining mounting pads, whether they be side or foot.

*** CAUTION:** If longer bolts (minimum grade 5) are substituted to mount winch or to mount a roller guide at the side mount pads, bolt length must be such as to allow a minimum of .50 inch thread length engagement in the tapped holes in side of each end bearing. Refer to pages 14-15. Use of excessive length bolts will damage the winch and prevent freespool of the drum. Torque bolts to 55 ft-lbs. (75 Nm).

CABLE INSTALLATION

An "A" or "B" decal on the clutch end bearing indicates the spooling direction of the cable. Also, a letter "A" or "B" is stamped in the end bearing on the clutch end indicating rotation direction. If the decal is damaged or unreadable, contact Customer Service for additional instructions to determine proper direction. **To reverse the rotation direction, exchange positions of the cartridge and plug shown below.**

1. Unwind cable by rolling it out along the ground to prevent kinking. Securely wrap end of cable, opposite hook, with plastic or similar tape to prevent fraying.
2. Place taped end of cable into hole in cable drum as shown below. Use the 3/8-16NC x 1/2" long hex socket drive setscrew (included with drum assembly item #1) to secure cable to drum.
3. Carefully run winch in the "reel-in" direction. Keeping tension on end of cable, spool all the cable onto the cable drum, taking care to form neatly wrapped layers.

After installing cable, check freespool operation. Disengage clutch and pull on cable at a walking speed. If cable "birdnests", loosen jam nut (item #20) and turn nylon setscrew (item #17) clockwise to increase drag on drum. If cable pull is excessive, loosen nylon setscrew by turning counterclockwise. Tighten jam nut when proper setting is obtained. **CAUTION: OVER-TIGHTENING OF JAM NUT MAY STRIP NYLON SETSCREW.**

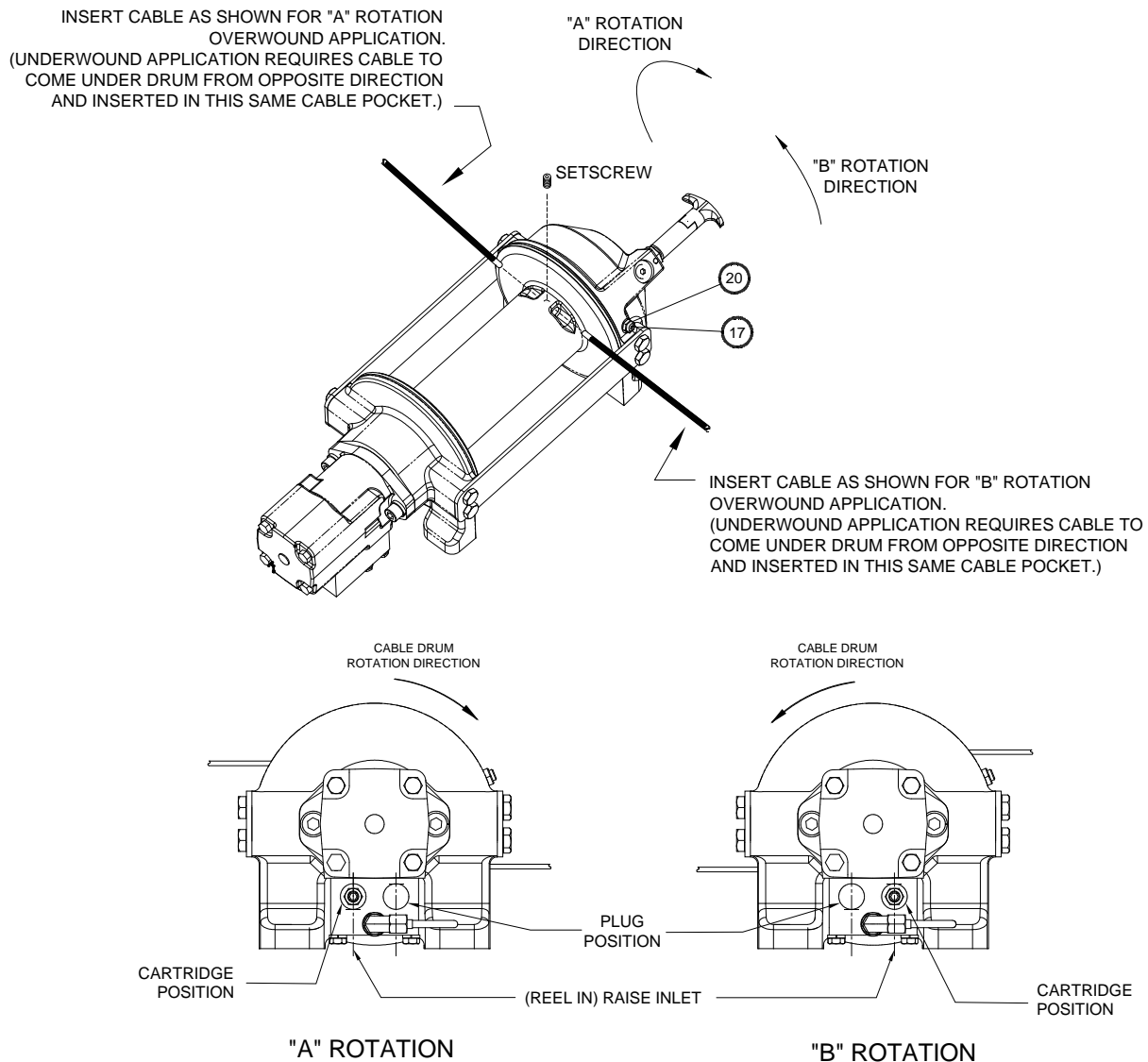

HYDRAULIC SYSTEM REQUIREMENTS

Refer to the performance charts below to properly match your hydraulic system to the winch performance. The charts consist of:

- (1) Line Pull first layer (lb.) vs. Working Pressure (PSI)
- (2) Line Speed, first layer (FPM) vs. flow (GPM)

SYSTEM REQUIREMENTS

MOTOR SPOOL (OPEN CENTER) CONTROL VALVE REQUIRED

2100 PSI RELIEF VALVE SETTING

15 GPM FLOW RATE

DO NOT EXCEED 20 GPM--MOTOR AND WINCH MAY BE DAMAGED

10 MICRON NOMINAL FILTRATION

TYPICAL LAYOUT

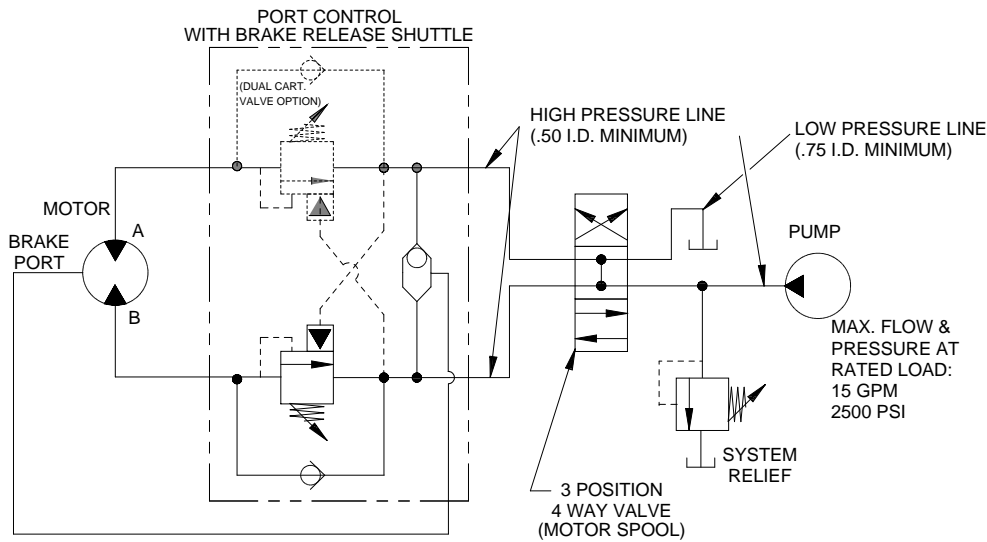

PERFORMANCE CHARTS

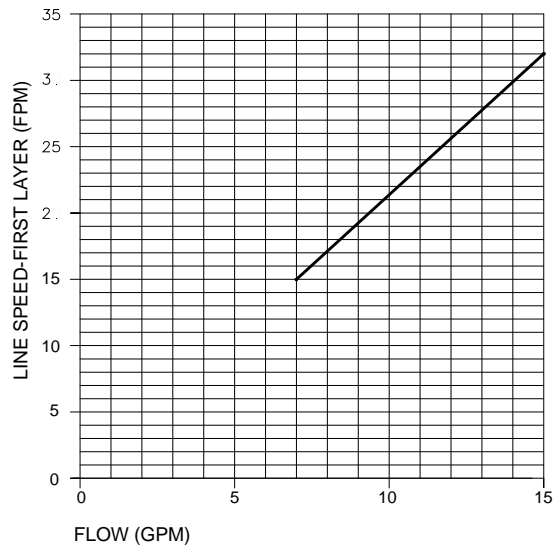
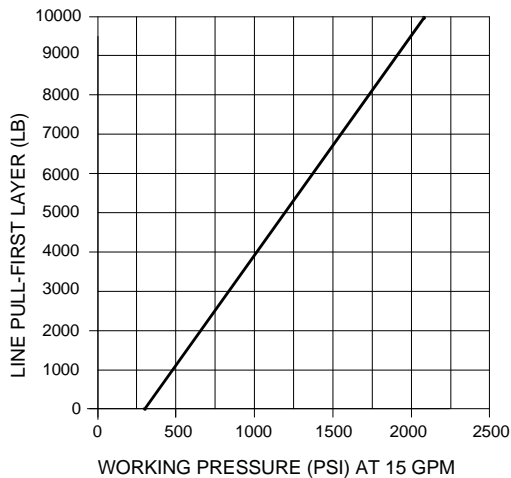

BASED ON 24.9 CU. IN. MOTOR

NOTE: Dual counterbalance valve version at Maximum Flow will require an increased working pressure of 150 PSI.

OPERATION

The best way to get acquainted with how your winch operates is to make test runs before you actually use it. Plan your test in advance. Remember, you hear your winch as well as see it operate. Get to recognize the sounds of a light steady pull, a heavy pull, and sounds caused by load jerking or shifting. Avoid conditions where load shifts or jerks occur, as they may indicate a dangerous situation.

The uneven spooling of cable, while pulling the load, is not a problem, unless there is a cable pileup on one end of the drum. If this happens, reverse the winch to relieve the load, and move your anchor point further to the center of the vehicle. After the job is done you can unspool and rewind for a neat lay of the cable.

When pulling a heavy load, place a blanket, jacket, and tarpaulin over the cable about five or six feet behind the hook. In the event of a broken cable, this will slow the snap back of the cable and could prevent serious injury.

The winch clutch allows rapid unspooling of the cable, from the cable drum, for hooking onto the load. The clutch is operated by the clutch shifter lever or air shifter.

WARNING: DO NOT DISENGAGE CLUTCH UNDER LOAD!

MANUAL CLUTCH SHIFTER (Refer to dimensional drawing page 14):

TO DISENGAGE CLUTCH: Run the winch in the reverse (reel out) direction until the load is off the cable. Pull handle out and rotate 90°. With handle in the “DISENGAGED” position, cable may now be free-spoiled from the drum.

TO ENGAGE CLUTCH: Pull handle out, rotate 90° and release handle. Run the winch in reverse until the clutch handle snaps fully into the “ENGAGED” position. **DO NOT** attempt to pull a load unless the handle is fully at the “ENGAGED” position. If manual shift indicator light is present, the green light is lit when clutch is fully “ENGAGED”. **DO NOT** attempt to pull a load unless the green light is lit. To install light to the vehicle electrical system refer to the Electrical Schematic on page 15.

AIR CYLINDER CLUTCH SHIFTER (Refer to the dimensional drawing page 15):

TO DISENGAGE CLUTCH: Run the winch in the reverse (reel out) direction until load is off the cable. Apply air pressure to the .125-27 NPT port: 80 PSI (min.)-150 PSI (max.). **CAUTION:** PRESSURE MUST NOT EXCEED 150 PSI.

TO ENGAGE CLUTCH: Remove air pressure from the cylinder (a return spring engages the plunger). Run winch in reverse until the clutch engagement indicator light (green light) is lit. To install light to the vehicle electrical system refer to the Electrical Schematic on page 15.

MAINTENANCE

1. Inspect the cable for damage and lubricate frequently. If the cable becomes frayed with broken strands, replace immediately. Cable and hook assembly (100' long cable) P/N 524118 (“Y” drum) or (150' long cable) P/N 524119 (STD drum) may be purchased from a Ramsey distributor.
2. Check that the clutch is fully engaging. See OPERATION instructions, above, for the appropriate clutch shifter. **FOR MANUAL CLUTCH ONLY:** Monthly, disengage clutch, put several drops of oil on the clutch handle shaft and work clutch handle IN and OUT several times to lubricate inside the shifter assembly.
3. Check to see that the drum cable does not overrun (“birdnest”) when freespooling. Refer to page 3 if it does.
4. Replace drum bushings and seals if seals begin to seep grease. Refer to the Overhaul Instructions, pages 7-12. Add additional lubricant, Mobilith SHC 007, to gears and drum bearings if required.

TROUBLESHOOTING GUIDE

CONDITIONS	POSSIBLE CAUSE	CORRECTION/ACTION
DRUM WILL NOT ROTATE AT NO LOAD	Winch not mounted squarely, causing end bearing to bind up	Check mounting. Refer to Winch Mounting, page 2.
	Gears damaged	Inspect and replace damaged gears
DRUM WILL NOT ROTATE UNDER LOAD	Winch not mounted squarely, causing end bearing to bind up	Check mounting. Refer to Winch Mounting, page 2.
	Load greater than rated capacity of winch	Refer to Specifications page 1 for line pull rating.
	Low hydraulic system pressure	Check pressure. Refer to Hydraulic Systems performance charts page 4.
WINCH RUNS TOO SLOW	Low hydraulic system flow rate	Check flow rate. Refer to System Requirements and Typical Layout page 4.
	Motor worn out	Replace motor
DRUM WILL NOT FREESPOOL	Clutch not disengaged. Check Adjustment of Manual Shifter, page 10.	Check Operation, page 5.
	Winch not mounted squarely, causing end bearing to bind up	Check mounting. Refer to Winch Mounting, page 2.
	Side mounted bolts too long, causing binding of ring gear (Item #15, page 16).	Check bolt length. Bolt thread MUST NOT engage threaded holes in sides of end bearing more than the .50 inch thread depth in the end bearing.
BRAKE WILL NOT HOLD	Incorrect directional control valve (cylinder spool-closed center)	Use only a motor spool (open center) control valve.
LOAD DRIFTS	Excessive Backpressure (100 PSI Max.)	Check for restrictions in hydraulic system. Refer to System Requirements and Typical Layout page 4.
CABLE BIRDNESTS WHEN CLUTCH IS DISENGAGED	Drag screw improperly adjusted	Adjust nylon drag screw. Refer to Cable Installation, page 3.
EXCESSIVE NOISE	Hydraulic system flow too high	Check flow rate. Refer to Typical Layout page 4.
	Drum in bind, winch not mounted squarely	Check mounting. Refer to Winch Mounting, page 2.
DRUM CHATTERS IN "REEL IN" DIRECTION	Low hydraulic system flow rate	Check flow rate. Refer to Typical Layout page 4.
	Low hydraulic system relief pressure setting	Check relief valve setting.
OIL LEAKS FROM BREATHER VENT UNDER MOTOR END BEARING	Damaged brake o-rings, backup rings, or sealing surfaces	Disassemble brake and inspect. See Overhaul Instructions, pg. 8.

INSTRUCTIONS FOR OVERHAUL HD-P10000 SERIES WINCH

Take note of mounting configurations for proper mounting of parts during re-assembly. Replace all gaskets, o-rings, and seals during re-assembly.

Disconnect tube (item #44) from elbow fittings (items #26) on bottom of end bearing and counterbalance valve (item #45). Remove motor (item #30) from end bearing by slowly unscrewing capscrews (items #18). **CAUTION: MOTOR IS UNDER SPRING PRESSURE.**

Check breather vent (item #45). Make sure it is not clogged. If oil is leaking from vent, check brake o-rings, backup rings, and sealing surfaces (see page 8).

Remove springs (items #43) from pockets and inspect for damage.

Replace gasket (item #28).

Remove coupling (item #25) from end bearing. Examine coupling for signs of wear, replace if necessary. If necessary, remove counterbalance valve from motor by removing capscrews (items #15).

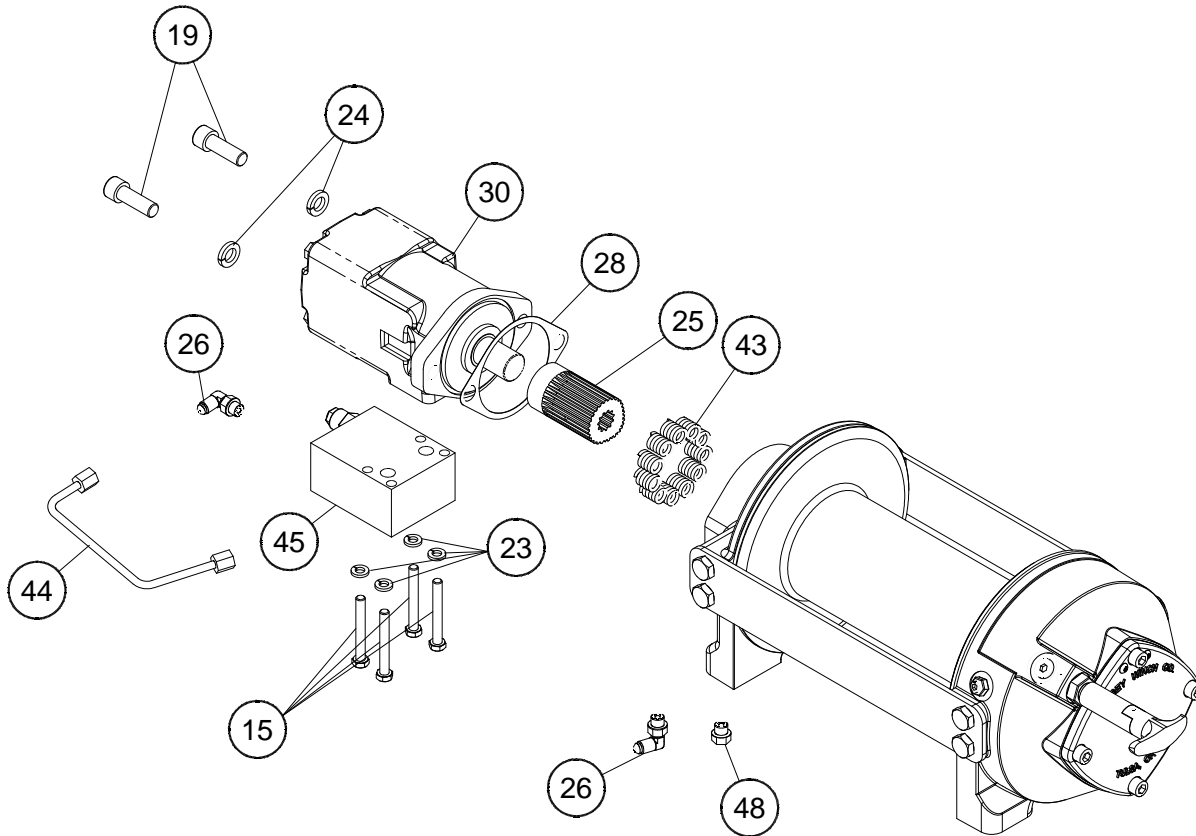

Remove retaining rings (items #42 and 49) with screwdriver.

Remove brake parts from end bearing. NOTE POSITION OF O-RINGS AND BACKUP RINGS BEFORE REMOVAL.

Examine brake discs (items #5) and stators (items #4) for signs of wear, and replace if necessary.

Examine o-rings (items #31 and 32) and backup rings (items #34 and 36) in brake piston (item #6), as well as o-ring (item #33) and backup ring (item #35) in backup brake piston (item #7) for signs of wear. Remove o-rings and backup rings from grooves in brake piston or backup brake piston and replace if necessary.

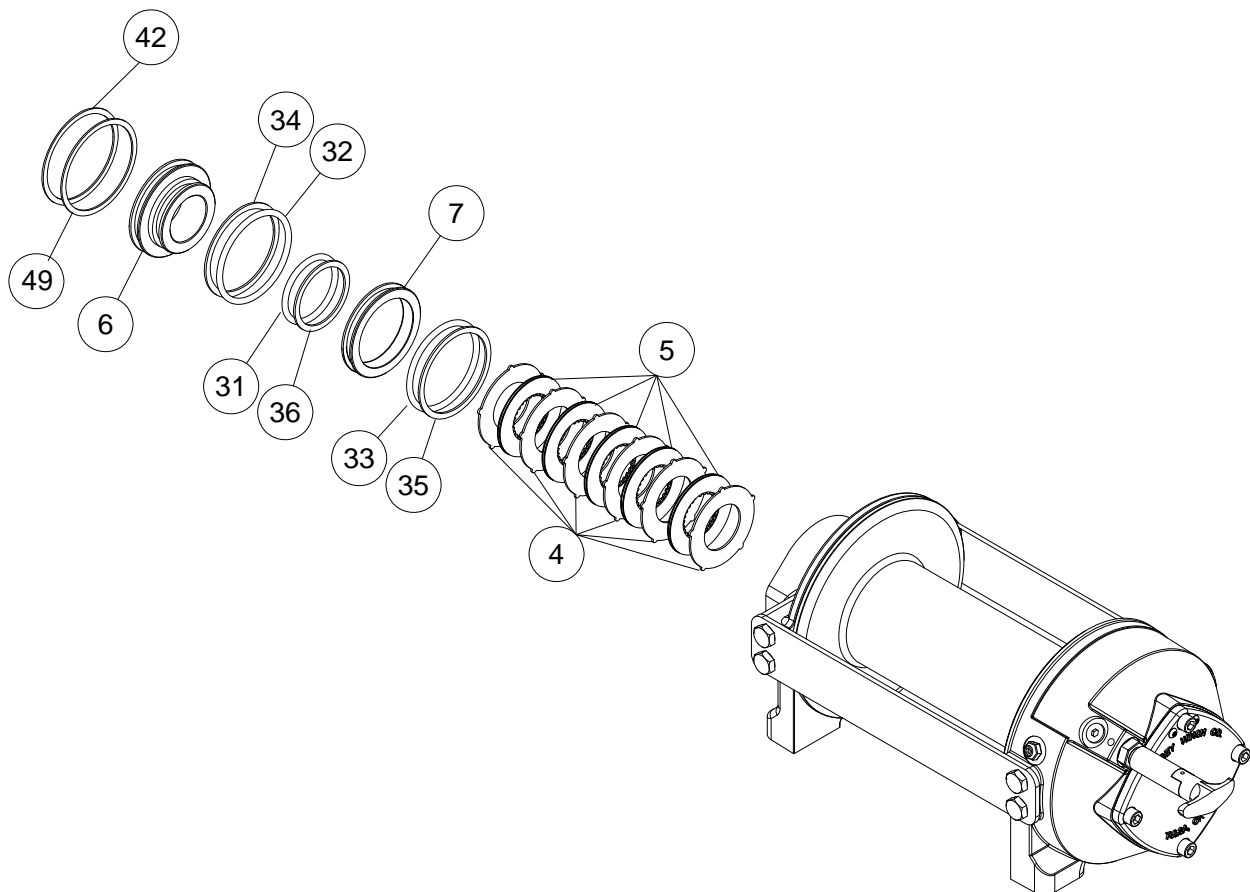

Remove tie plates (items #12) from end bearings by unscrewing capscrews (items #16). Slide motor end bearing (item #10) and drum (item #1) from gear housing end bearing.

Remove input shaft (item #11) from end bearing. Inspect shaft and output sun gear (item #8) for damage and replace if necessary. To remove the output sun gear, remove the snap rings (items #41) and thrust washer (item #47) and pull off the end of the shaft.

Remove bushing (item #14) and o-ring (item #37) from motor end bearing. Place new, well-oiled o-ring into groove inside of end bearing and press new bushing onto end bearing.

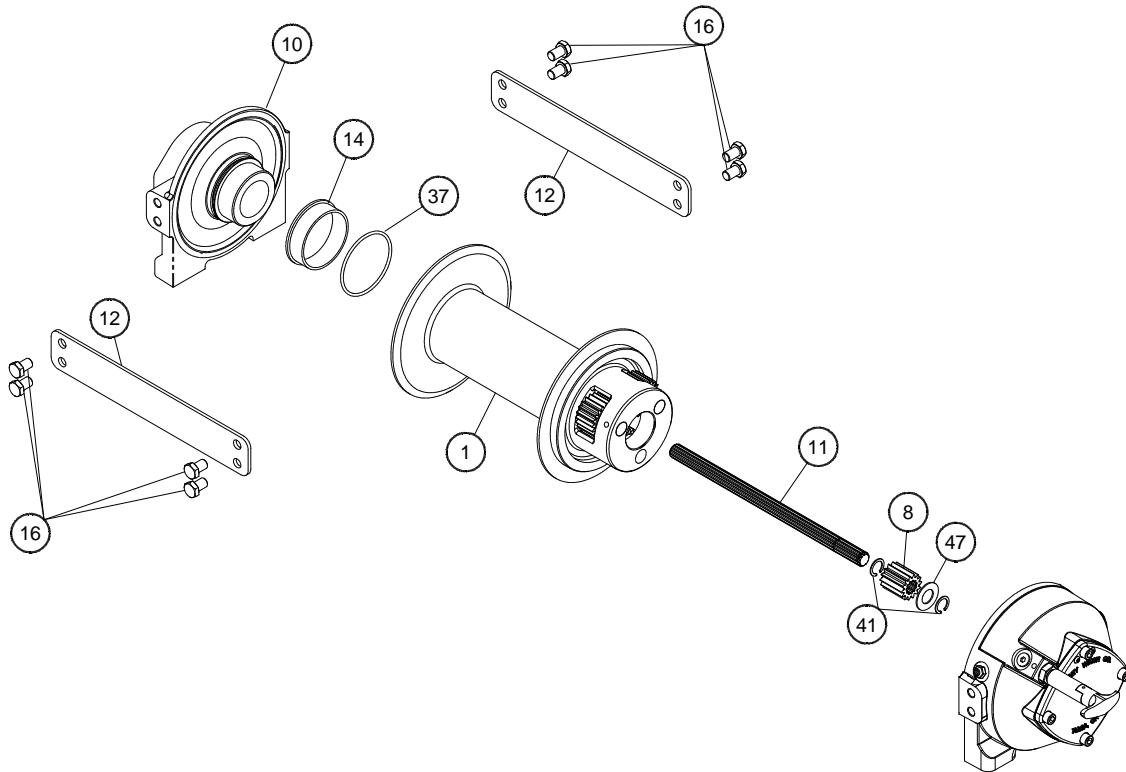

Remove seal (item #40) from gear housing end bearing (item #9). Loosen nut (item #22) and remove nylon setscrew (item #18). Remove ring gear from gear housing end bearing, if necessary. Remove bushing (item #13) from end bearing.

Press new bushing into end bearing. Install ring gear, then nylon setscrew and nut. Ring gear must be fully seated in end bearing and slot in ring gear **MUST NOT** be aligned with clutch shifter hole. Install new seal in end bearing, with sharp edge of seal outward.

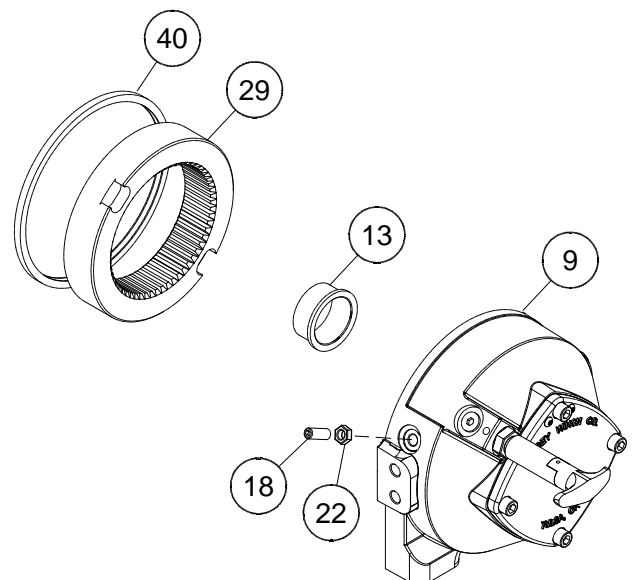

Generously apply grease (MOBILITH SHC 007) to teeth of ring gear (item #29), teeth of planet gears in drum (item #1), and to bushing (item #13) in gear housing end bearing. Apply a small amount of grease to base of bushing (item #14) on motor end bearing. Apply grease to teeth of output sun gear (item #8) and input shaft (item #11).

Place end of shaft with output sun gear on it into drum. Rotate shaft to engage planet gears with output sun gear. Place Gear End Bearing on Drum and engage planet gears with ring gear.

Assemble motor end bearing (item #10) to drum assembly and use tie plates (items #12) and capscrews (items #16) to hold both end bearings together. Tighten capscrews to 55 ft-lbs (75 Nm).

If necessary, remove and replace the shifter assembly (manual, item #2, or air-cylinder, item #3), as follows:

MANUAL CLUTCH SHIFTER ASSEMBLY

Loosen setscrew (item #20) and jam nut on shifter assembly, then unscrew shifter assembly (item #2). Be sure slot in ring gear is not aligned with clutch shifter hole. Rotate drum, if necessary, to ensure hole and slot are not aligned.

Reinstall shifter assembly with plunger, jam nut, and handle positioned in gear housing as shown below. Thread assembly (with handle engaged in cylinder slot) into the gear housing. Pull drum toward the gear end bearing housing to remove play. Hold drum in position and continue threading the shifter assembly in until the gap between the end of the handle and cylinder is $7/16 +0 -1/16$ inch and handle is in the horizontal position (see below). **Note:** This gap will vary with drum endplay. With the drum pulled against the motor end housing, the gap should be 3/8 inch.

Lightly tighten jam nut. Rotate drum until handle snaps fully into the engaged position. Pull handle out and rotate 90°. Verify that drum can be rotated freely (at least one full revolution) with clutch shifter at the DISENGAGED position. Securely tighten jam nut while holding the handle. Tighten setscrew (item #20) securely. Re-check clutch operation as described on page 5.

AIR CYLINDER SHIFTER ASSEMBLY

Loosen set screw (item #20) to remove shifter assembly (item #3). To reinstall, place 1 or 2 shims (items #44) over plunger and thread shifter assembly into gear end housing. Add or remove shims to orient ports for pneumatic connections. Ports should point down (below horizontal). Tighten setscrew. Check for clutch operation as described on page 5.

If the light assembly (item #2) or light switch (item #48) needs to be replaced, refer to the schematic on page 15 for electrical connections and disassemble and reassemble as shown below.

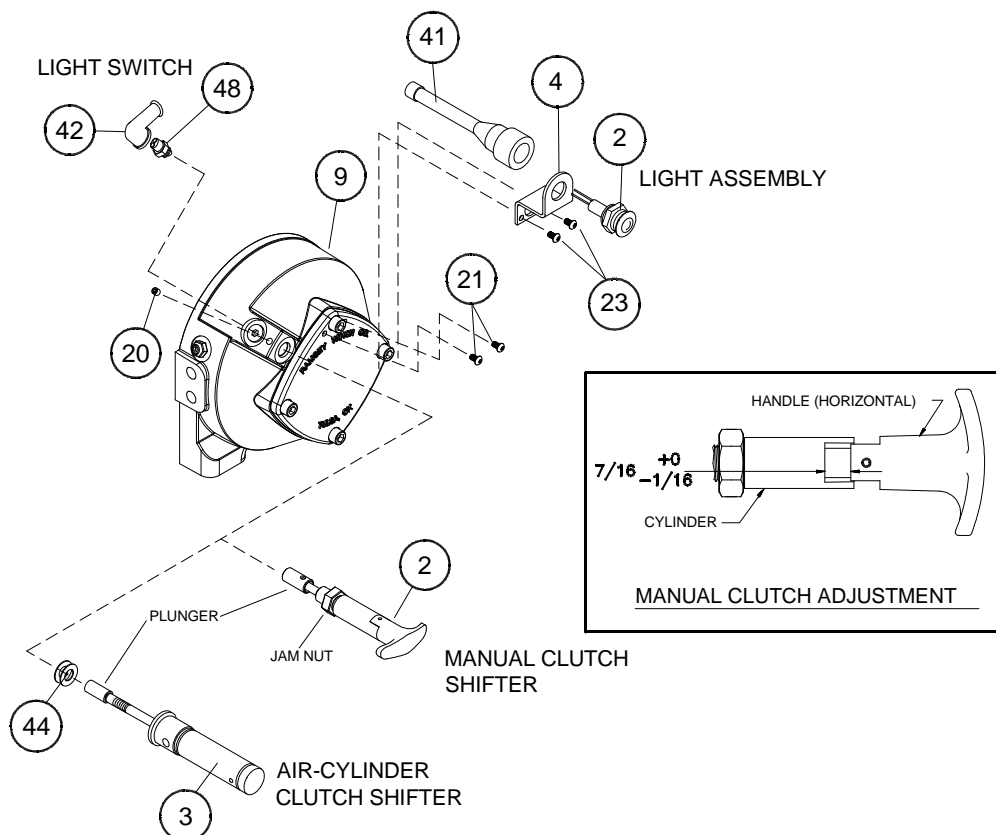

Set winch with gear housing end down on work surface.

Install well-oiled o-rings and backup rings into grooves on outside of brake piston and backup brake piston as shown in cross-section A-A below.

Piston, backup piston, brake discs and stators must be clean and free of grease and oil.

Insert brake discs (item #5) and stators (item #4) into gear end alternating, with stators first and last.

Insert backup brake piston (item #7) into motor end and insert brake piston (item #6) into it. **Apply even pressure on piston when installing.**

Install retaining rings (items #42 and 49) into grooves in motor end housing.

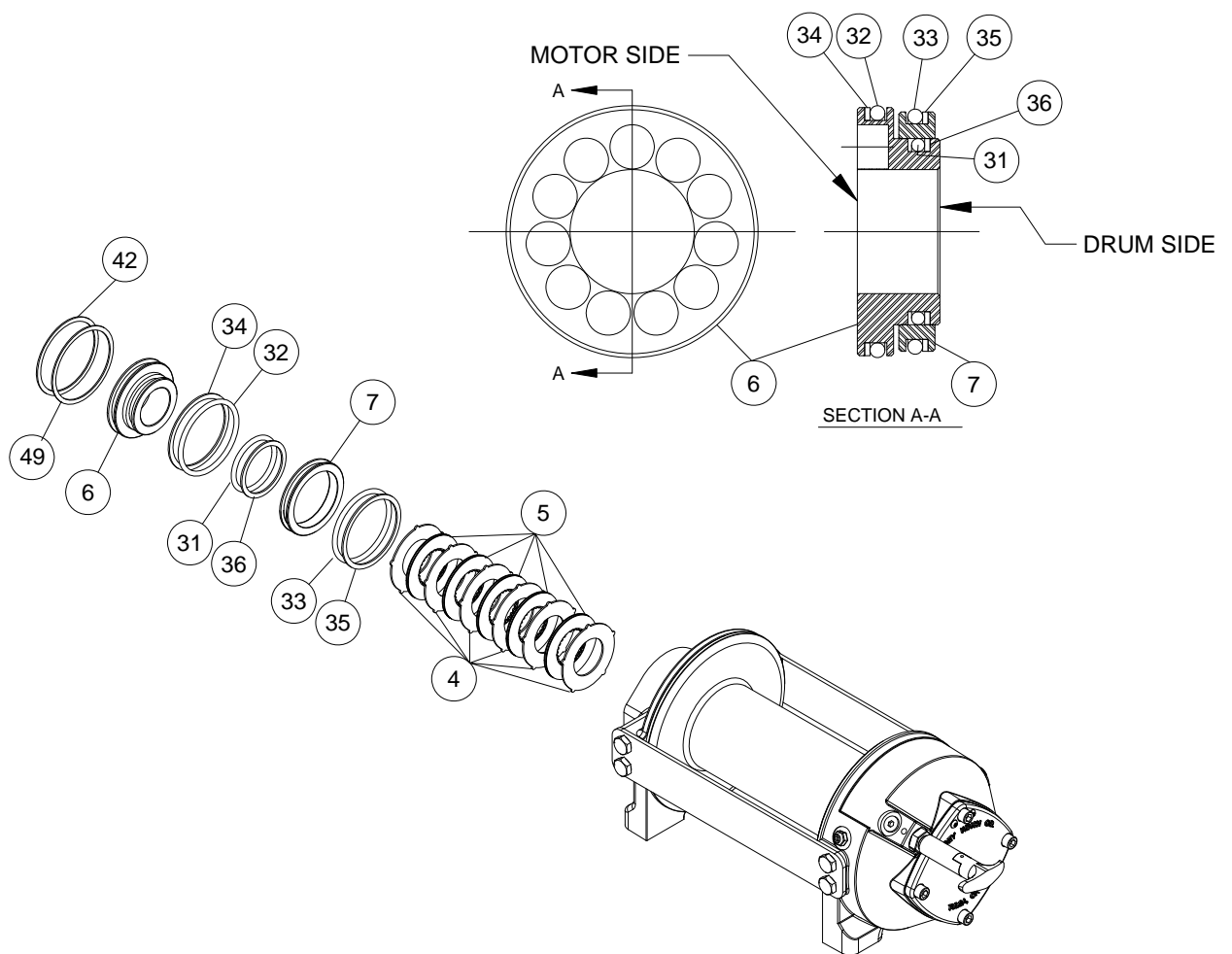

Insert springs (item #43) into pockets in back of brake piston.

Install roll pin (item #38) into new motor coupling below bottom of spline teeth. Insert motor coupling (item #25), engaging it with the discs and the input shaft.

Place gasket (item #28) on mounting surface of motor (item #30). Slide motor shaft into coupling. Attach motor to motor end bearing housing using (2) capscrews (item #19) and (2) lockwashers (item #24). Evenly tighten to 49 ft-lbs. (66 Nm) torque.

Install the counterbalance valve (item #45) to the motor using (4) capscrews (item #15) and (4) lockwashers (item #23). Tighten to 17 ft-lbs (23 Nm).

Securely connect fittings (item #26) to motor end housing and counterbalance valve, and connect tube assembly (item #44) to fittings.

Apply at least 550 PSI hydraulic system pressure to brake and verify that brake releases (winch drum will rotate).

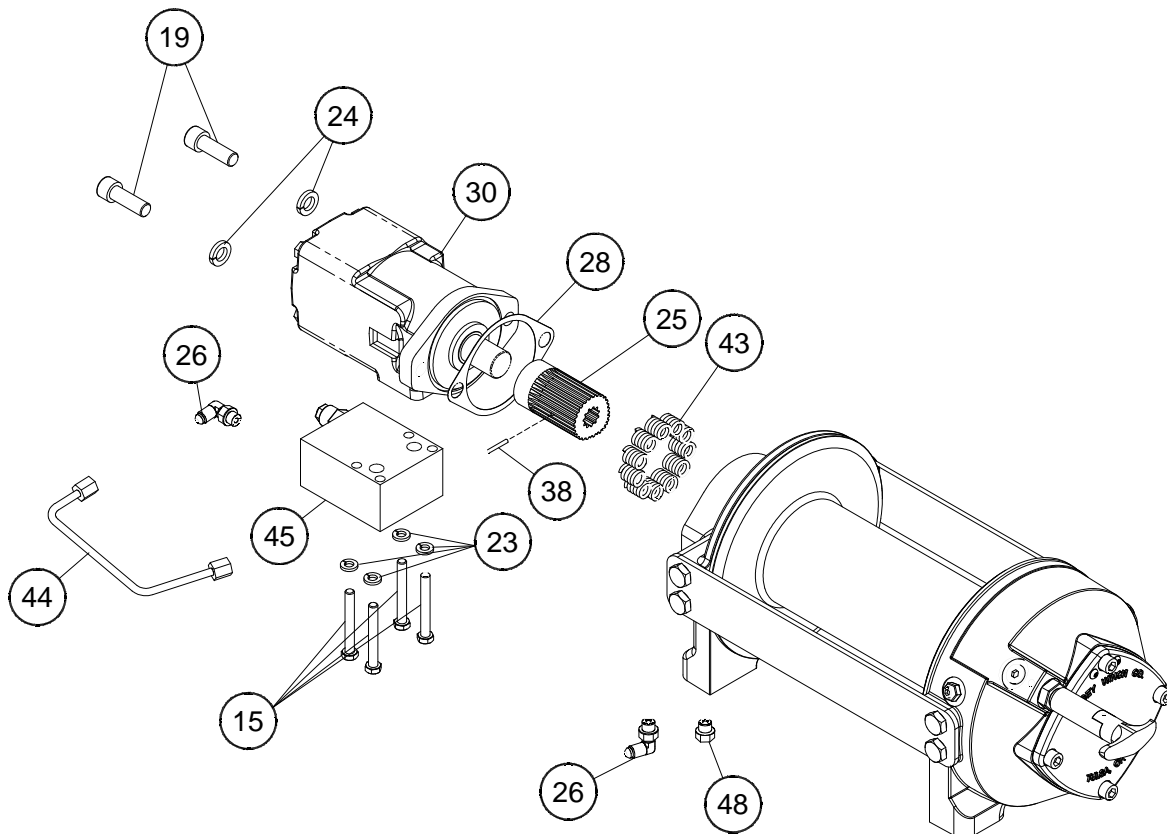

NOTES

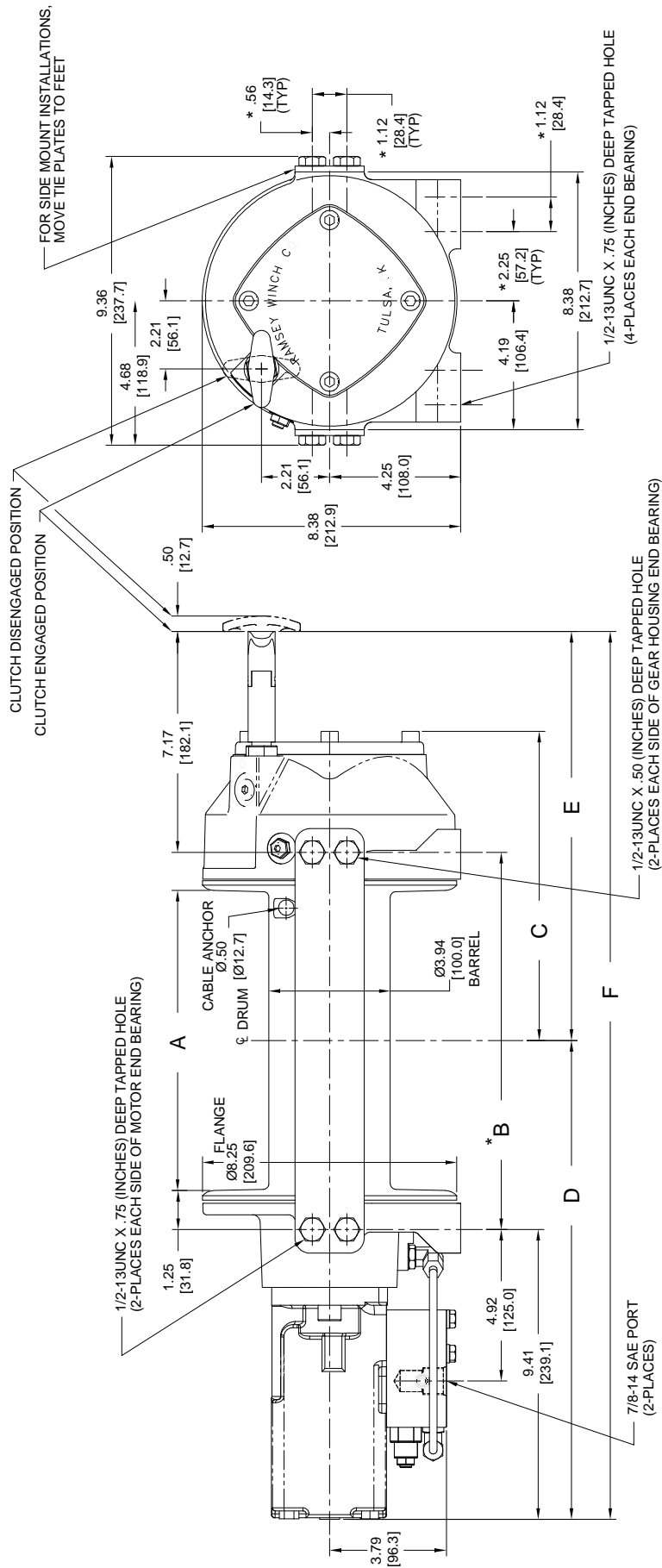

- NOTES:
1. DIMENSIONS SHOWN ARE INCHES OVER MILLIMETERS.
 2. WINCH MOUNTING CAPSCREWS MUST MEET OR EXCEED SAE GRADE 5 SPECIFICATION.
 - * 3. THESE HOLE LOCATIONS MUST BE HELD WITHIN ±.03 (0.8mm) OF TRUE POSITION. RECOMMENDED MOUNTING HOLE DIAMETER IS .53 (13.5mm).

WINCH MODEL	A INCHES MM	B INCHES MM	C INCHES MM	D INCHES MM	E INCHES MM	F INCHES MM
HD-P10000	9.75	12.25	10.04	15.55	13.28	28.84
STD. DRUM	247.7	311.2	255.0	394.9	337.3	732.5
HD-P10000 "Y" DRUM	6.50 165.1	9.00 228.6	8.41 213.6	13.93 353.8	11.66 296.1	25.59 649.9

HD-P10000 MANUAL SHIFT

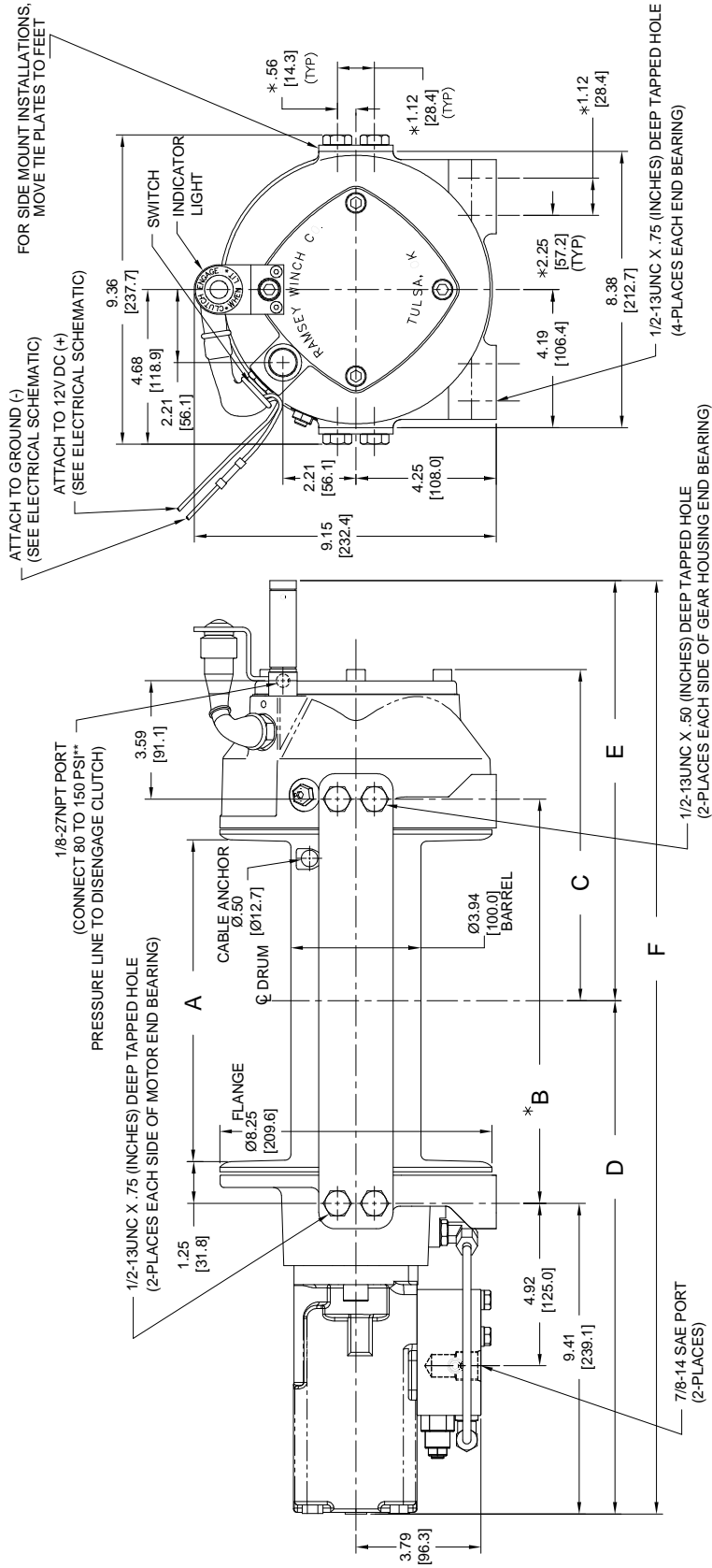

NOTES:

1. DIMENSIONS SHOWN ARE INCHES OVER MILLIMETERS.
2. WINCH MOUNTING CAPSCREWS MUST MEET OR EXCEED SAE GRADE 5 SPECIFICATION.

* 3. THESE HOLE LOCATIONS MUST BE HELD WITHIN ±.03 (0.8mm)

OF TRUE POSITION. RECOMMENDED MOUNTING HOLE DIAMETER IS .53 (13.5mm).

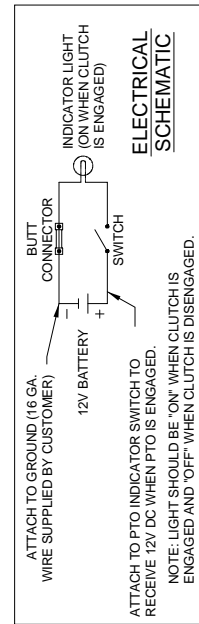

WINCH MODEL	A INCHES MM	B INCHES MM	C INCHES MM	D INCHES MM	E INCHES MM	F INCHES MM
HD-P10000	9.75	12.25	10.04	15.55	12.72	28.28
STD. DRUM	247.7	311.2	255.0	394.9	323.1	718.3
HD-P10000	6.50	9.00	8.41	13.93	9.47	24.99
"Y" DRUM	165.1	228.6	213.6	353.8	240.5	634.7

HD-P10000 AIR SHIFT

PARTS LIST - MANUAL SHIFT

Item No.	Quantity	Part No.	Description	Item No.	Quantity	Part No.	Description
1	1	234207	DRUM ASSY STD	27	1	442212	GASKET-GEAR HOUSING COVER
	1	234208	DRUM ASSY "Y"	28	1	442223	GASKET-MOTOR FLANGE
2	1	276048	SHIFTER ASSY	29	1	444084	GEAR-RING
3	1	328164	COVER-GEAR HOUSING	30	1	458079	MOTOR-HYD.
4	6	330011	STATOR-BRAKE	31	1	462067	O-RING PISTON-SM.
5	5	330012	DISC-BRAKE	32	1	462068	O-RING PISTON-LG.
6	1	330013	PISTON-BRAKE	33	1	462069	O-RING BACKUP PISTON
7	1	330014	PISTON-BACKUP BRAKE	34	1	462070	RING-BACKUP PISTON-LG
8	1	334174	GEAR-OUTPUT, SUN	35	1	462071	RING-BACKUP BACKUP PISTON
9	1	338327	END BEARING-GEAR HOUSING	36	1	462072	RING-BACKUP PISTON-SM
10	1	338358	END BEARING-MOTOR	37	1	462073	O-RING
11	1	357177	SHAFT-INPUT STD DRUM	38	1	470033	SPIROL PIN
		357176	SHAFT-INPUT "Y" DRUM	39	1	472052	PLUG
12	2	395427	PLATE-TIE STD DRUM	40	1	486080	SEAL
		395426	PLATE-TIE "Y" DRUM	41	2	490003	SNAP RING
13	1	412085	BUSHING-DRUM	42	1	490049	RING-INTERNAL RETAINING
14	1	412109	BUSHING-DRUM, MOTOR END	43	11	494124	SPRING-BRAKE
15	4	414159	CAPSCREW-5/16-18UNC X 2 1/2", HEX HEAD, ZINC, GR5	44	1	509132	TUBE-BRAKE RELEASE (PORTS DOWN)
16	8	414581	CAPSCREW-1/2-13NC X 3/4", HEX HEAD, ZINC, GR5			509131	TUBE-BRAKE RELEASE (PORTS UP)
17	4	414901	CAPSCREW-3/8-16NC X 3/4", HEX SOCKET HEAD	45	1	516041	VALVE-MOTOR CONTROL (A ROTATION)
18	1	414926	SETSCREW-3/8-16NC X 1", SOCKET HEAD, NYLON			516042	VALVE-MOTOR CONTROL (B ROTATION)
19	2	414954	CAPSCREW-1/2-13NC X 1 3/4", SOCKET HEAD, ZINC			516043	VALVE-MOTOR CONTROL SIDE PORTS (A ROT)
20	1	416016	SETSCREW-1/4-20NC X 1/4", HEX SOCKET HEAD CUP			516044	VALVE-MOTOR CONTROL SIDE PORTS (B ROT)
21	2	416239	SCREW-#10-24NC X 3/8", HEX SOCKET BUTTON HEAD			516013	VALVE-MOTOR CONTROL (DUAL CART.)
22	1	418036	NUT-3/8-16 NC, HEX JAM, ZINC	46	1	518037	THRUST WASHER
23	4	418163	LOCKWASHER-5/16 MED SECT, ZINC	47	1	518047	THRUST WASHER
24	2	418218	LOCKWASHER-1/2 ID MED SECT, ZINC	48	1	456038	BREATHER VENT
25	1	431020	COUPLING-MOTOR	49	1	490066	RING-INTERNAL RETAINING
26	2	432018	FITTING				

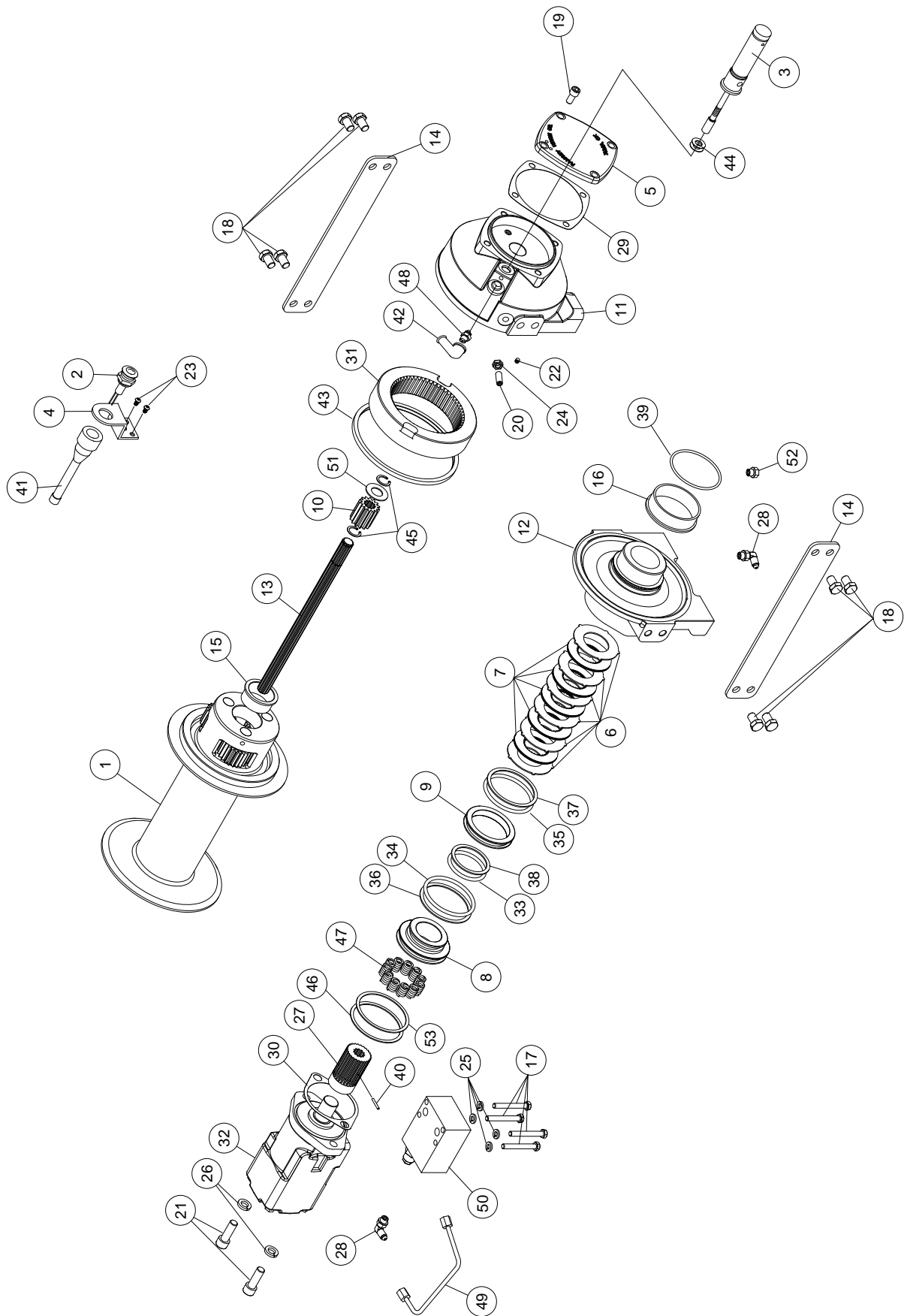

PARTS LIST - AIR SHIFT

Item No.	Quantity	Part No.	Description	Item No.	Quantity	Part No.	Description
1	1	234207	DRUM ASSY STD	29	1	442212	GASKET-GEAR HOUSING COVER
2	1	234208	DRUM ASSY "Y"	30	1	442223	GASKET-MOTOR FLANGE
3	1	236020	LIGHT ASSY	31	1	444084	GEAR-RING
4	1	276058	SHIFTER ASSY	32	1	458079	MOTOR-HYD.
5	1	312569	BRACKET - LIGHT ASSY	33	1	462067	O-RING PISTON-SM.
6	1	328164	COVER-GEAR HOUSING	34	1	462068	O-RING PISTON-LG
7	6	330011	STATOR-BRAKE	35	1	462069	O-RING BACKUP PISTON
8	5	330012	DISC-BRAKE	36	1	462070	RING-BACKUP PISTON-LG
9	1	330013	PISTON-BRAKE	37	1	462071	RING-BACKUP PISTON
10	1	330014	PISTON-BACKUP BRAKE	38	1	462072	RING-BACKUP PISTON-SM
11	1	334174	GEAR-OUTPUT, SUN	39	1	462073	O-RING
12	1	338327	END BEARING-GEAR HOUSING	40	1	470033	SPIROL PIN
13	1	338358	END BEARING-MOTOR	41	1	482013	RUBBER BOOT
14	2	357176	SHAFT-INPUT "Y" DRUM	42	1	482045	RUBBER BOOT
15	2	395427	SHAFT-TIE STD DRUM	43	1	486080	SEAL
16	1	395426	PLATE-TIE "Y" DRUM	44	2	488007	SHIM
17	1	412085	BUSHING-DRUM	45	2	490003	SNAP RING
18	4	412109	BUSHING-DRUM, MOTOR END	46	1	490049	RING-INTERNAL RETAINING
19	8	414581	CAPSCREW-5/16-18UNC X 2 1/2", HEX HEAD, ZINC, GR5	47	11	494124	SPRING-BRAKE
20	4	414581	CAPSCREW-1/2-13NC X 3/4", HEX HEAD, ZINC, GR5	48	1	504021	SWITCH
21	4	414901	CAPSCREW-3/8-16NC X 3/4", HEX SOCKET HEAD	49	1	509132	TUBE-BRAKE RELEASE (PORTS DOWN)
22	2	414926	SETSCREW-3/8-16NC X 1", SOCKET HEAD, NYLON	50	1	509131	TUBE-BRAKE RELEASE (PORTS UP)
23	2	414954	CAPSCREW-1/2-13NC X 1 3/4", SOCKET HEAD, ZINC			516041	VALVE-MOTOR CONTROL A ROTATION
24	1	416016	SETSCREW-1/4-20NC X 1/4" HEX SOCKET HEAD CUP			516042	VALVE-MOTOR CONTROL B ROTATION
25	4	416239	SCREW-#10-24NC X 3/8", HEX SOCKET BUTTON HEAD			516043	VALVE-MOTOR CONTROL SIDE PORTS (A ROT)
26	4	418036	NUT-3/8-16 NC, HEX JAM, ZINC			516044	VALVE-MOTOR CONTROL SIDE PORTS (B ROT)
27	2	418163	LOCKWASHER-5/16 MED SECT, ZINC	51	1	516013	VALVE-MOTOR CONTROL (DUAL CART.)
28	2	418218	LOCKWASHER-1/2 ID MED SECT, ZINC	52	1	518047	THRUST WASHER
	1	431020	COUPLING-MOTOR	53	1	456038	BREATHER VENT
	2	432018	FITTING			490066	RING-INTERNAL RETAINING

KITS AND MAINTENANCE PARTS

123168

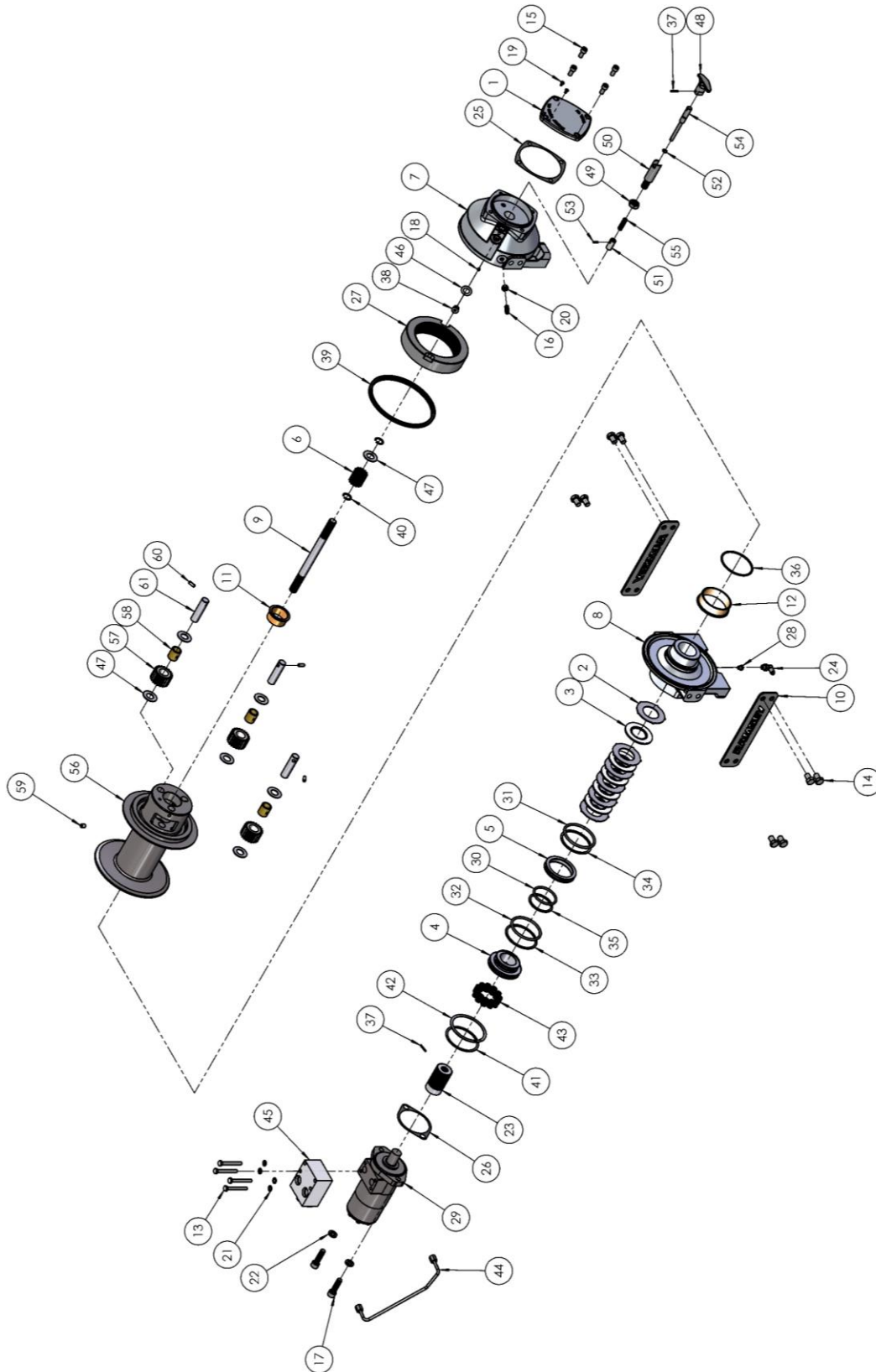

KITS AND MAINTENANCE PARTS

123168

Item#	QTY.	PART NUMBER	DESCRIPTION	KITS						
				207023	207024	248065	222069	293034	283088	246066
1	1	328164	COVER-GEAR HSG							
2	6	330011	STATOR-BRAKE	X						
3	5	330012	DISC-BRAKE	X						
4	1	330013	PISTON-BRAKE		X					
5	1	330014	PISTON-BACKUP BRAKE		X					
6	1	334174	GEAR-OUTPUT,SUN							
7	1	338327	GEAR HSG. END BEARING							
8	1	338358	END BEARING-MOTOR							
9	1	357176	SHAFT-INPUT							
10	2	395426	PLATE-TIE							
11	1	412085	BUSHING-DRUM,GEAR END			X				
12	1	412109	BUSHING-DRUM, MOTOR END			X				
13	4	414159	CS-5/16-18UNCX2.50,HXHD,GR5							
14	8	414581	CAPSCREW-1/2-13NCX3/4LG,HXHD G5							
15	4	414901	CAPSCREW-3/8-16NCX3/4LG HEX SOC HD							
16	1	414926	SETSCREW-3/8-16NC X1,SOCKET							
17	2	414954	CAPSCREW 1/2-13NC X 1/3/4 LG. SOCHD							
18	1	416016	SETSCREW1/4-20NCX1/4 HX SOCK HD CUP				X			
19	2	416239	SCREW-#10-24NC X3/8,HXSOCBUTTHD							
20	1	418036	NUT-3/8-16 NC,HEX JAM							
21	4	418163	LOCKWASHER-5/16 MED SECT							
22	2	418218	LOCKWASHER-1/2 ID MED SECT							
23	1	431020	COUPLING-MOTOR		X				X	
24	1	432018	FITTING 7/16-20 90 degree							
25	1	442212	GASKET-BRK HSG,.031THK.							X
26	1	442223	GASKET-MOTOR FLANGE						X	X
27	1	444140	GEAR-RING, FORGED							
28	1	456038	FITTING-VENT,BREATHER							
29	1	458185	MOTOR-HYD							
30	1	462067	O-RING-2.225 ID X .210 THK	X						X
31	1	462068	O-RING-3.10 ID X .210 THK	X						X
32	1	462069	O-RING-2.975 ID X .210 THK							X
33	1	462070	RING-BACKUP, 3.143 ID X .076 THK	X						X
34	1	462071	RING-BACKUP, 3.018 ID X .076 THK							X
35	1	462072	RING-BACKUP, 2.268 ID X .076 THK	X						X
36	1	462073	O-RING-3.234 ID X .139 THK							X
37	2	470033	SPIROL PIN-1/8X7/8				X		X	
38	1	472052	PLUG-SAE O-RING,.562-18NF							
39	1	486080	SEAL-GH							X
40	2	490003	SNAP RING, .693 ID X .045 THK							
41	1	490049	RING-INTERNAL RETAINING, 3.250 ID X .061 THK	X						
42	1	490066	RING-INTERNAL RETAINING, 3.466 ID X .054 THK							
43	11	494124	SPRING-BRAKE	X						

KITS AND MAINTENANCE PARTS

123168

Item#	QTY.	PART NUMBER	DESCRIPTION	KITS						
				207023	207024	248065	222069	293034	283088	246066
44	1	509131	ASSEMBLY-TUBE							
45	1	516042	VALVE-MOTOR CONTROL							
46	1	518037	THRUST WASHER, .031 THK.X1.105 OD			X				
47	7	518047	WASHER-THRUST,.063 THK.X1.50 OD			X		X		
48	1	336026	HANDLE-SHIFTER				X			
49	1	418088	NUT-JAM 5/8-18NF HEX HD				X			
50	1	426041	CYLINDER-CLUTCH				X			
51	1	426042	PLUNGER-CLUTCH				X			
52	1	462045	O-RING-1/16X1/2OD X3/8ID				X			X
53	1	470088	PIN-SPRING				X			
54	1	489015	SHAFT-SHIFTER				X			
55	1	494104	SPRING-SHIFTER				X			
56	1	332215	DRUM-CABLE					X		
57	3	334173	GEAR-OUTPUT,PLANET					X		
58	3	412089	BUSHING-PLANET,OUTPUT					X		
59	1	416059	SETSCREW3/8-16NCX1/2 HX SOCK HD CUP							
60	3	470086	ROLL PIN-1/4 X 11/16LG					X		
61	3	470090	PIN-PLANET					X		

KITS AND MAINTENANCE PARTS

123174

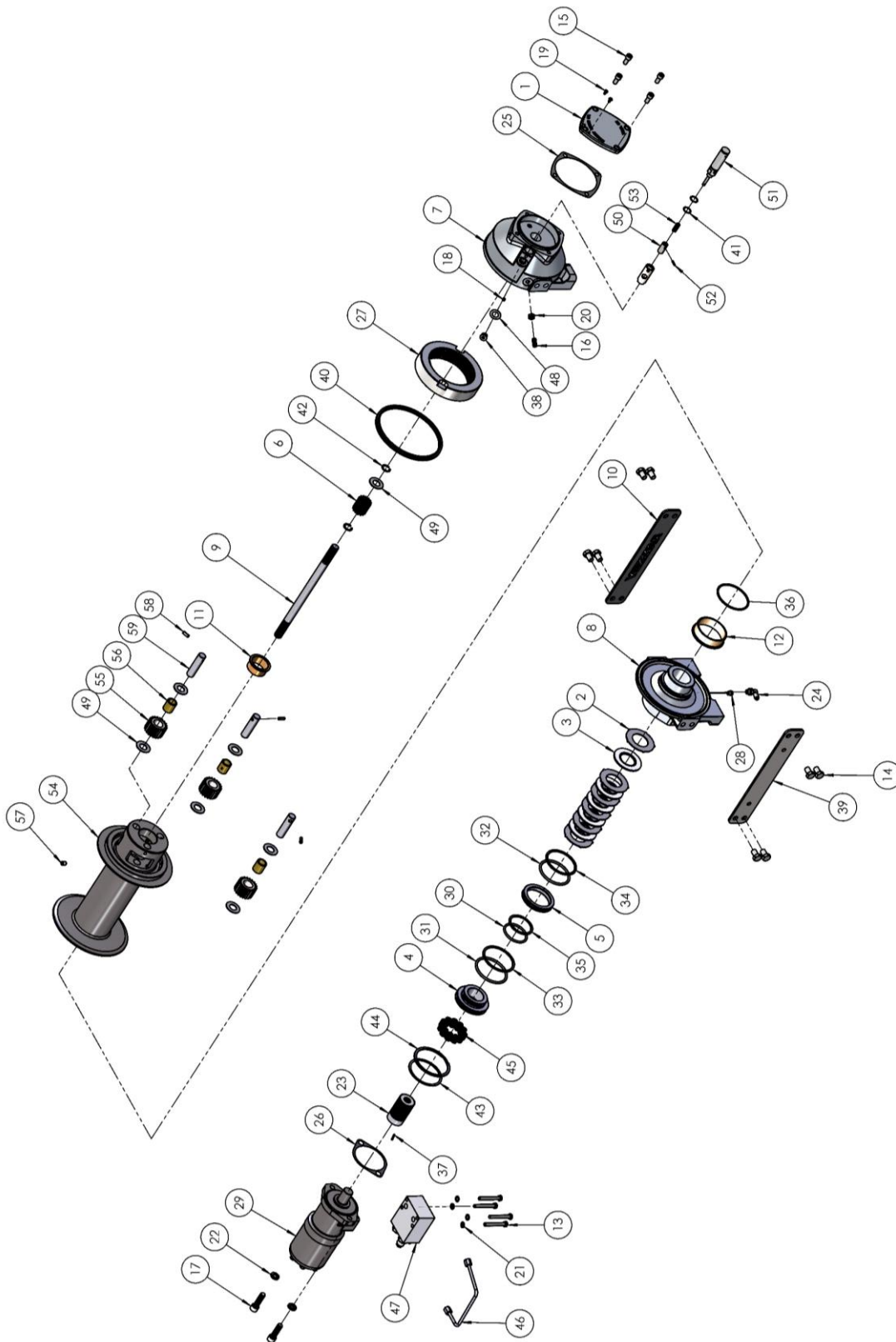

KITS AND MAINTENANCE PARTS

123174

Item#	QTY.	PART NUMBER	DESCRIPTION	KITS						
				207023	207024	248065	222071	293035	283088	246066
1	1	328164	COVER-GEAR HSG							
2	6	330011	STATOR-BRAKE	X						
3	5	330012	DISC-BRAKE	X						
4	1	330013	PISTON-BRAKE		X					
5	1	330014	PISTON-BACKUP BRAKE		X					
6	1	334174	GEAR-OUTPUT,SUN							
7	1	338327	GEAR HSG. END BEARING							
8	1	338358	END BEARING-MOTOR							
9	1	357177	SHAFT-INPUT							
10	1	395427	PLATE-TIE							
11	1	412085	BUSHING-DRUM,GEAR END			X				
12	1	412109	BUSHING-DRUM, MOTOR END			X				
13	4	414159	CS-5/16-18UNCX2.50,HXHD,GR5							
14	8	414581	CAPSCREW-1/2-13NCX3/4LG,HXHD,G5							
15	4	414901	CAPSCREW-3/8-16NCX3/4LG HEX SOC HD							
16	1	414926	CAPSCREW-3/8-16NCX3/4LG HEX SOC HD							
17	2	414954	CAPSCREW 1/2-13NC X 1/3/4 LG. SOCHD							
18	1	416016	SETSCREW1/4-20NCX1/4 HX SOCK HD CUP				X			
19	2	416239	SCREW-#10-24NC X3/8,HXSOCBUTTHD							
20	1	418036	NUT-3/8-16 NC,HEX JAM							
21	4	418163	LOCKWASHER-5/16 MED SECT							
22	2	418218	LOCKWASHER-1/2 ID MED SECT							
23	1	431020	COUPLING-MOTOR		X				X	
24	1	432018	FITTING 7/16-20 90 degree							
25	1	442212	GASKET-BRK HSG,.031THK							X
26	1	442223	GASKET-MOTOR FLANGE						X	X
27	1	444140	GEAR-RING							
28	1	456038	FITTING-VENT,BREATHER							
29	1	458079	MTR-HYD							
30	1	462067	O-RING-2.225 ID X .210 THK	X						X
31	1	462068	O-RING-3.10 ID X .210 THK	X						X
32	1	462069	O-RING-2.975 ID X .210 THK							X
33	1	462070	RING-BACKUP, 3.143 ID X .076 THK	X						X
34	1	462071	RING-BACKUP, 3.018 ID X .076 THK							X
35	1	462072	RING-BACKUP, 2.268 ID X .076 THK	X						X
36	1	462073	O-RING-3.234 ID X .139 THK							X
37	1	470033	SPIROL PIN-1/8X7/8						X	
38	1	472052	PLUG-SAE O-RING,.562-18NF							
39	1	474056	TIE PLATE-UNIVERSAL							
40	1	486080	SEAL-GH							X
41	2	488007	SHIM-AIR CYLINDER							
42	2	490003	SNAP RING, .693 ID X .045 THK							
43	1	490049	RING-INTERNAL RETAINING, 3.250 ID X .061 THK	X						

KITS AND MAINTENANCE PARTS

123174

Item#	QTY.	PART NUMBER	DESCRIPTION	KITS						
				207023	207024	248065	222071	293035	283088	246066
44	1	490066	RING-INTERNAL RETAINING, 3.466 ID X .054 THK							
45	11	494124	SPRING-BRAKE	X						
46	1	509132	TUBE-BRAKE RELEASE							
47	1	516042	VALVE-MOTOR CONTROL							
48	1	518037	THRUST WASHER, .031 THK.X1.105 OD			X				
49	7	518047	WASHER-THRUST,.063 THK.X1.50 OD			X		X		
50	1	426042	PLUNGER-CLUTCH				X			
51	1	433027	AIR CYLINDER CLUTCH SHIFTER				X			
52	1	470088	PIN-SPRING				X			
53	1	494103	SPRING-SHIFTER				X			
54	1	332216	DRUM-CABLE, MACHINED					X		
55	3	334173	GEAR-OUTPUT,PLANET					X		
56	3	412089	BUSHING-PLANET,OUTPUT					X		
57	1	416059	SETSCREW3/8-16NCX1/2 HX SOCK HD CUP							
58	3	470086	ROLL PIN-1/4 X 11/16LG					X		
59	3	470090	PIN-PLANET					X		

**RAMSEY WINCH INDUSTRIAL WINCH
LIMITED WARRANTY**

1.1 Scope of Warranty Coverage. Upon the terms and subject to the conditions set forth in this limited warranty:

- (a) RAMSEY WINCH (referred to herein as “**RAMSEY WINCH**” or the “**Manufacturer**”) warrants to each initial end user customer (a “**Purchaser**”) of a new industrial winch together with any accessories manufactured and sold directly from RAMSEY WINCH (the “**Product**”) that the Product shall be free from defects in material and workmanship, under normal working and service conditions, for a period of eighteen (18) months from the date the Product is shipped from RAMSEY WINCH. (the “**Warranty Term**”). A Purchaser shall be eligible for an additional eighteen (18) months of coverage in addition to the Warranty Term (also referred to as the “**Standard (+) PLUS benefit**”) only if the Purchaser (i) complies with Section 1.2(a) and (ii) registers the Product during the Warranty Term at myproduct.ramseywinch.com.
- (b) Notwithstanding the foregoing, this warranty does not cover components damaged by accident, abuse, misuse, neglect, untrained operators, collision, overloading, modification, disassembly, rework, misapplication, improper installation, lack of lubrication or maintenance, or improper service. This warranty does not cover the paint or material finish, rope (wire or synthetic), removal or reinstallation of the winch, or normal wear and tear and loss of functionality due to aging of the Product (which may include but is not limited to bearings, bushings, seals, O-rings, gaskets, brake material, motor brushes, electrical cables and more).

1.2 Eligibility of Warranty Coverage.

- (a) A Purchaser shall be eligible for warranty coverage under this Limited Warranty during the Warranty Term only if:
 - (i) Prior to placing a Product in service, and throughout use of the Product during the Warranty Term, the Purchaser provides (or causes to be provided) proper storage such that foreign objects (e.g. rain or debris) cannot enter any Product through entry ports which are normally closed during operation.; and
 - (ii) The Purchaser maintains, or causes to be maintained, the Product according to commercially reasonable standards and utilizes the Product for the purposes for which it was created; and
 - (iii) No repairs or alterations have been made by any party other than RAMSEY WINCH, including Purchaser, unless otherwise authorized in writing by RAMSEY WINCH.

1.3 Transferability of Warranty.

- (a) This warranty is transferable only from the Purchaser to the first subsequent transferee (the “**Transferee**”) of the Product from Purchaser upon (i) written notification to RAMSEY WINCH and (ii) registration of the transfer, both within 30 days of such Product transfer.
- (b) Upon satisfaction of transfer requirements set forth in Section 1.3(a), the Transferee shall succeed to all the rights and obligations of the Purchaser set forth in this Limited Warranty.

1.4 Certain Limitations on Scope of Warranty Service.

- (a) Any obligation of RAMSEY WINCH under this warranty, statutory or otherwise, is limited to the repair of the Product, at its factory or Authorized Service Centers. Notwithstanding the foregoing, if field service or repair is performed by RAMSEY WINCH at the request of the Purchaser and no defect is found with material or workmanship of the Product, the Purchaser shall compensate RAMSEY WINCH for its time and expenses within thirty (30) days of delivery of an invoice relating to the same. If repair is determined by RAMSEY WINCH in its sole, absolute and uncontrolled discretion to be impossible or impractical, then RAMSEY WINCH may satisfy this warranty by replacing the Product. RAMSEY WINCH will not provide any cash payment or credits for defective materials or workmanship.

- (b) Purchaser shall be responsible for any and all freight charges for any Product receiving warranty service under this limited warranty. Any travel time, transportation charges, freight charges, or similar costs incurred by RAMSEY WINCH in connection with the replacement or repair of defective parts, shall, be the responsibility of the Purchaser. If applicable, RAMSEY WINCH shall invoice Purchaser for the total amount of such charges within sixty (60) days of fulfilling its duties under this warranty, payable within thirty (30) days of delivery of such invoice. In no event shall RAMSEY WINCH be liable for bills for service, labor or other expenses that have been incurred by the Purchaser without approval or prior authorization by RAMSEY WINCH for inspection, maintenance, or repair of the Product.
- (c) If a Product is found to be operable upon inspection, the Product, at Purchaser's election, may be either (1) returned to the Purchaser with a service charge from RAMSEY WINCH for inspection, cleaning, and routine replacement of all rubber components and any other parts that show wear; or (2) RAMSEY WINCH can dispose of the product safely.

1.5 **Limitations of Liability.** RAMSEY WINCH shall in no event be liable for punitive, special or consequential damages relating to the Product or this Warranty. RAMSEY WINCH makes no warranty in respect to third-party accessories, upgrades, or additions to the Product.

1.6 **Improving Product.** RAMSEY WINCH reserves the right to improve the Product through changes in design or materials as it may deem desirable or necessary without being obligated to incorporate, upgrade, or otherwise modify previously manufactured products.

1.7 **Limitations of Warranty.**

- (a) THE WARRANTY SET FORTH ABOVE IS THE ONLY EXPRESS WARRANTY. RAMSEY WINCH HEREBY DISCLAIMS AND EXCLUDES ANY OTHER EXPRESS, IMPLIED, OR STATUTORY WARRANTIES, ARISING BY OPERATION OF LAW, COURSE OF DEALING, COURSE OF PERFORMANCE, USAGE, OF TRADE, OR OTHERWISE, INCLUDING, WITHOUT LIMITATION, ANY WARRANTIES OF MERCHANTABILITY, FITNESS FOR A PARTICULAR PURPOSE, AND INTELLECTUAL PROPERTY RIGHTS OF A THIRD PARTY.
- (b) ANY IMPLIED WARRANTY WHICH BY LAW MAY NOT BE EXCLUDED IS LIMITED IN DURATION TO ONE (1) YEAR FROM THE DATE OF ORIGINAL RETAIL PURCHASE OF THE PRODUCT.
- (c) This warranty gives you specific legal rights, and you may also have other rights which vary from jurisdiction to jurisdiction.
- (d) This warranty is valid only in the U.S.A. and Canada. For warranty outside the U.S.A. and Canada contact your nearest Ramsey Winch Distributor.

1.8 **No Modifications to Warranty.** No RAMSEY WINCH dealer, distributor, agent or employee is authorized to make any modification, extension or addition to this warranty.

1.9 **How to Apply for Warranty Coverage.**

All claims are handled by contacting your nearest Ramsey Winch Distributor. For questions, please contact customer support: rwcustomersupport@ramseyindustries.com.

Visit [Dealer Locator - Ramsey Winch](#) for Ramsey Winch Distributor locations and contact information.

Additional warranty, service support, product information, and parts information can be found on www.ramseywinch.com.

