

WILDCAT[®] WINCH SERIES

By **RAMSEY
WINCH[®]**

OPERATING, SERVICE AND MAINTENANCE MANUAL



WILDCAT 105K MODEL WC 105R 105,000 LB INDUSTRIAL WINCH



CAUTION: READ AND UNDERSTAND THIS MANUAL
BEFORE INSTALLATION AND OPERATION OF WINCH.
SEE WARNINGS!

TABLE OF CONTENTS

WARRANTY INFORMATION	1
SPECIFICATIONS	1
WARNINGS	1
HYDRAULIC SYSTEM REQUIREMENTS	2
CABLE INSTALLATION	3
CLUTCH OPERATION	4
WINCH OPERATION	4
MAINTENANCE	4
LUBRICATION TABLE	5
TROUBLE SHOOTING GUIDE	5
INSTRUCTIONS FOR DISASSEMBLY	6-13
HOSE HOOKUP	14
PARTS DRAWING	15
PARTS LIST	16
AIR CYLINDER	17
DIMENSIONAL DRAWING	18

RAMSEY HYDRAULIC PLANETARY WINCH MODEL WILDCAT 105K

PLEASE READ THIS MANUAL CAREFULLY

This manual contains useful ideas in obtaining the most efficient operation from your Ramsey Winch, and safety procedures one needs to know before operating a Ramsey Winch. Do not operate this winch until you have carefully read and understand the "WARNINGS" and "OPERATION" sections of this manual.

WARRANTY INFORMATION

Ramsey Winches are designed and built to exacting specifications. Great care and skill go into every winch we make. If the need should arise, warranty procedure is outlined on the back of your self-addressed postage paid warranty card. Please read and fill out the enclosed warranty card and send it to Ramsey Winch Company. If you have any problems with your winch, please follow instructions for prompt service on all warranty claims. Refer to back page for limited warranty.

PERFORMANCE										
APPROXIMATE WEIGHT:		2150 LBS								
WORKING PRESSURE:		2850 PSI								
CABLE DIAMETER:		1 1/8 INCH								
FLOW:		60 GPM								
LAYER	CABLE CAPACITY		LOW SPEED				HIGH SPEED			
			LINE PULL		LINE SPEED		LINE PULL		LINE SPEED	
	Ft	m	Lb	Kg	fpm	mpm	Lb	Kg	fpm	mpm
1	45	13	105000	47620	23	6.9	49000	22220	46	13.9
2	105	32	85900	38960	27	8.2	40000	18140	55	16.7
3	180	54	72600	32930	32	9.7	33900	15370	64	19.4
4	260	79	63000	28570	36	10.9	29400	13330	73	22.1
5	355	108	55500	25170	41	12.4	25900	11740	82	24.9
6	465	141	49700	22540	46	13.9	23200	10520	92	27.9

* These specifications are based on recommended wire rope of 1.125" Extra Improved Plow Steel Cable and a 9.6 cu. in. / Rev. motor.

NOTE: The rated line pulls shown are for the winch only. Consult the wire rope manufacturer for wire rope ratings.

WARNINGS:

CLUTCH MUST BE FULLY ENGAGED BEFORE STARTING THE WINCHING OPERATION.

DO NOT START WINCH MOTOR BEFORE ENGAGING CLUTCH.

DO NOT DISENGAGE CLUTCH UNDER LOAD.

STAY OUT FROM UNDER AND AWAY FROM RAISED LOADS.

STAND CLEAR OF CABLE WHILE PULLING. DO NOT TRY TO GUIDE CABLE.

DO NOT EXCEED MAXIMUM LINE PULL RATINGS SHOWN IN TABLE.

DO NOT USE WINCH TO LIFT, SUPPORT, OR OTHERWISE TRANSPORT PEOPLE.

A MINIMUM OF 5 WRAPS OF CABLE AROUND THE DRUM BARREL IS NECESSARY TO HOLD THE LOAD.

CABLE ANCHOR IS NOT DESIGNED TO HOLD LOAD.

BAND BRAKE IS NOT TO BE USED TO HOLD LOAD.

HYDRAULIC SYSTEM REQUIREMENTS & PERFORMANCE CHARTS

HYDRAULIC SYSTEM REQUIREMENTS

Refer to the performance charts, below, to properly match your hydraulic system to winch performance. The charts consist of:

(1) Line pull (lb.) first layer vs. working pressure (PSI) and (2) line speed, first layer (FPM) vs. gallons per minute (GPM). Performance based on a motor displacement of 9.0 cubic inches/rev with 60 GPM maximum flow rate. Motor has (2) 1"-12 SAE straight thread o-ring ports.

Note: A motor spool (open center) directional control valve is required for brake operation.

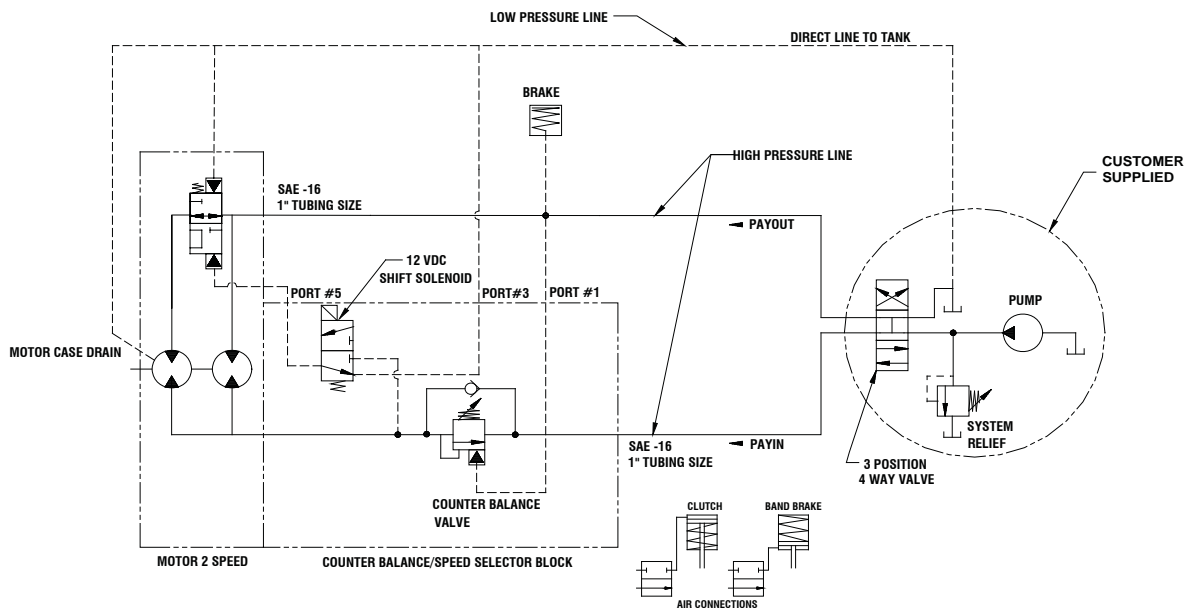

PERFORMANCE CHARTS

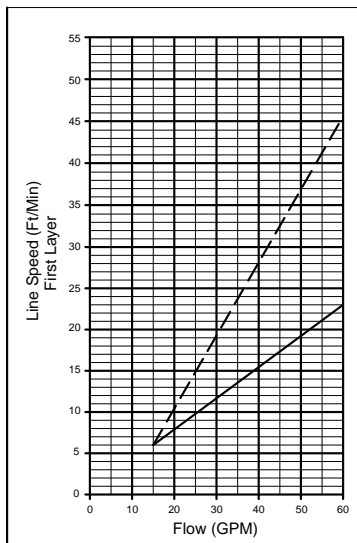
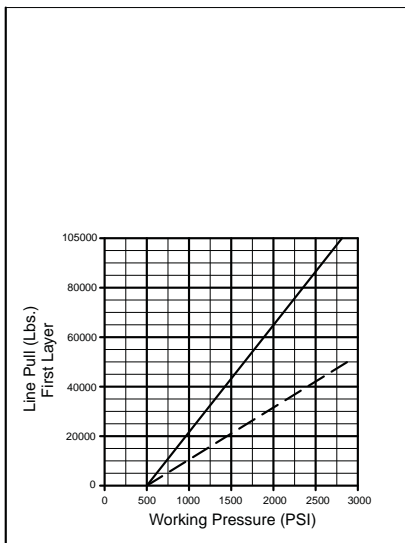

BASED ON 9.6 CU IN/REV MOTOR

CABLE INSTALLATION

CABLE INSTALLATION

1. Unwind cable by rolling it out along the ground to prevent kinking. Securely wrap end of wire rope, opposite hook, with plastic or similar tape to prevent fraying.
2. Place taped end of cable into hole on drum flange and bend into the track on drum flange. Secure using supplied u-bolt #73 and (2) nuts.
3. Carefully run the winch in the "reel-in" direction. Keeping tension on end of cable, spool all the cable onto the cable drum, taking care to form neatly wrapped layers.
4. After installing cable, band brake is used to prevent bird nesting while pulling out cable, when clutch is disengaged.

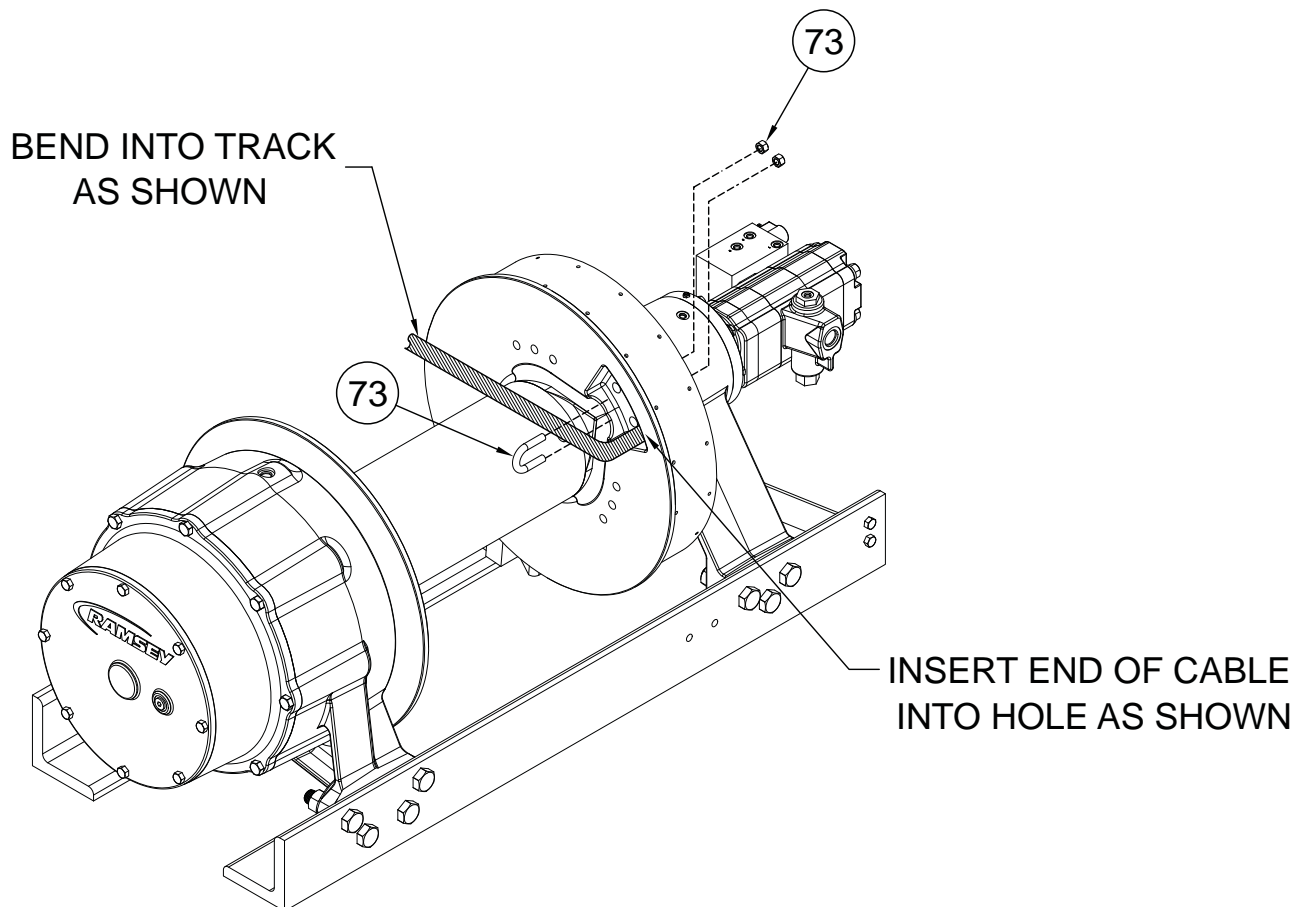

CLUTCH OPERATION

CLUTCH OPERATION

WARNING: CLUTCH MUST BE FULLY ENGAGED BEFORE STARTING THE WINCHING OPERATION.

To engage clutch:

1. Move clutch control to engage the clutch.
2. Run the motor in the cable out direction until the drum begins to turn.

WARNING: DO NOT DISENGAGE CLUTCH UNDER LOAD.

To disengage clutch:

1. Run the winch in the "cable out" direction until the load is off the cable.
2. Move the clutch control to disengage the clutch. The cable may now be spooled off.

WINCH OPERATION

The best way to get acquainted with how your winch operates is to make test runs before you use it. Plan your test in advance. Remember, you hear your winch, as well as see it operate; learn to recognize the sounds of a light steady pull, a heavy pull, and sounds caused by load jerking or shifting. Gain confidence in operating your winch and its use will become second nature with you.

The uneven spooling of cable while pulling a load is not a problem, unless there is a cable pileup on one end of drum. If this happens reverse the winch to relieve the load and move your anchor point further to the center of the vehicle. After the job is done you can unspool and rewind for a neat lay of the cable.

MAINTENANCE

Adhering to the following maintenance schedule will keep your winch in top condition and performing as it should with a minimum of repair.

Drum bushings are oil impregnated with synthetic oil. The drum bushings do not require additional grease.

A. WEEKLY

1. Check the oil level and maintain it to the oil level plug. If oil is leaking out, determine location and repair.
2. Check the pressure relief plug on the gear housing cover and the brake housing cover. Be sure they are not plugged.
3. Lubricate cable with light oil.
4. Apply a high quality lithium grease to clutch spline. Apply band brake to control drum. Declutch drum and apply grease to spline between clutch and drum.

B. MONTHLY

1. Check the winch mounting bolts. If any are missing, replace them and securely tighten any that are loose. Use grade 8 or better bolts.
2. Inspect the cable. If the cable has become frayed with broken strands, replace immediately.

C. ANNUALLY

1. Drain the oil from the winch annually or more often if winch is used frequently.
2. Refill the winch to the oil level plug with all purpose GL-5 oil, (see page 5) for gear lube compatible with your climate.
3. Inspect winch for damage and wear.

LUBRICATION TABLE AND TROUBLE SHOOTING GUIDE

LUBRICATION TABLE

Lubricant Description*	Temp Range F(C)		
	Min Ambient & Operating	Max Ambient	Max Operating
80W140 Synthetic	-25 (-32)	125 (52)	225 (107)
75W90 Synthetic	-40 (-40)	115 (46)	215 (102)
80W90 Conventional	-20 (-29)	100 (38)	180 (82)
85W140 Conventional	20 (6)	120 (50)	200 (93)
*Use API GL-5 or EP lubricants.			

TROUBLE SHOOTING GUIDE

CONDITIONS	POSSIBLE CAUSE	CORRECTION
OIL LEAKS FROM WINCH	<ol style="list-style-type: none"> 1. Seals damaged or worn. 2. Too much oil. 3. Damaged o-rings. 4. Case drain not connected. 	<ol style="list-style-type: none"> 1. Replace seal 2. Drain excess oil. Refer to page 6. 3. Replace o-rings. 4. Connect case drain.
WINCH RUNS TOO SLOW	<ol style="list-style-type: none"> 1. Low flow rate. 2. Hydraulic motor worn out. 	<ol style="list-style-type: none"> 1. Check flow rate. Refer to HYDRAULIC SYSTEMS performance chart on page 2. 2. Replace motor.
CABLE DRUM WILL NOT FREESPOOL	<ol style="list-style-type: none"> 1. Clutch not disengaged 	<ol style="list-style-type: none"> 1. Check operation. Refer to Clutch Operation on page 4.
BRAKE WILL NOT HOLD	<ol style="list-style-type: none"> 1. Incorrect directional control valve. (cylinder spool, closed center). 2. Excessive hydraulic system back pressure. 3. Sprag clutch worn out. 	<ol style="list-style-type: none"> 1. Use only a motor spool (open center) directional control valve. 2. Reduce system back pressure to less than 100 psi. 3. Replace sprag clutch mechanism.
BRAKE WILL NOT RELEASE	<ol style="list-style-type: none"> 1. Brake line disconnected or blocked 	<ol style="list-style-type: none"> 1. Repair brake line.
WINCH WILL NOT OPERATE AT HIGH SPEED	<ol style="list-style-type: none"> 1. Shift solenoid not working. 	<ol style="list-style-type: none"> 1. Verify shift spool is energized.
WINCH OPERATES ERRATICALLY ON INHAUL	<ol style="list-style-type: none"> 1. Sprag hub is reversed. 	<ol style="list-style-type: none"> 1. Install sprag hub correctly.

DISASSEMBLY INSTRUCTIONS

INSTRUCTIONS FOR DISASSEMBLY

1. Remove wire rope from drum.
2. Drain oil from winch by removing (2) plugs #63, removing the lower plug first.
3. When replacing lubricant, use 496 oz of applicable lube for your climate from table on page 5, adding 16 oz at #52 and the remaining at #64.

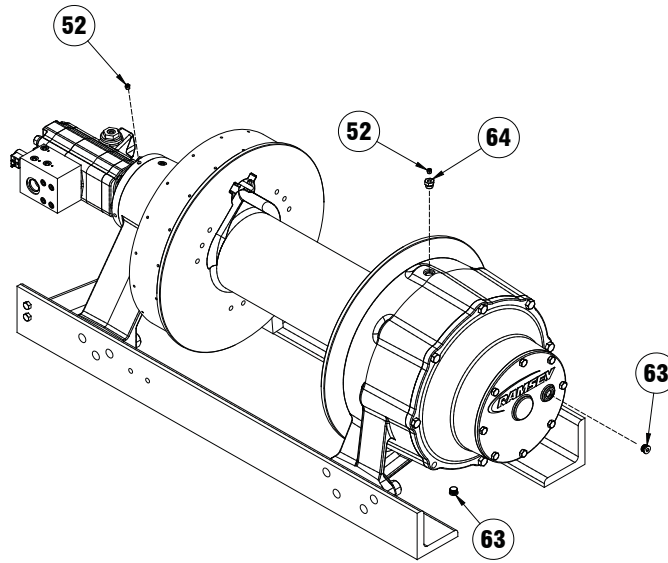

4. Remove (2) nuts #408b from air cylinder #408a. Air cylinder may now be removed. If needed, mounting bracket #401 may be removed by removing pin #404 from pin #405 and then sliding pin out of mounting bracket. Brake band #6 may be expanded over drum flange to barrel for easiest removal.

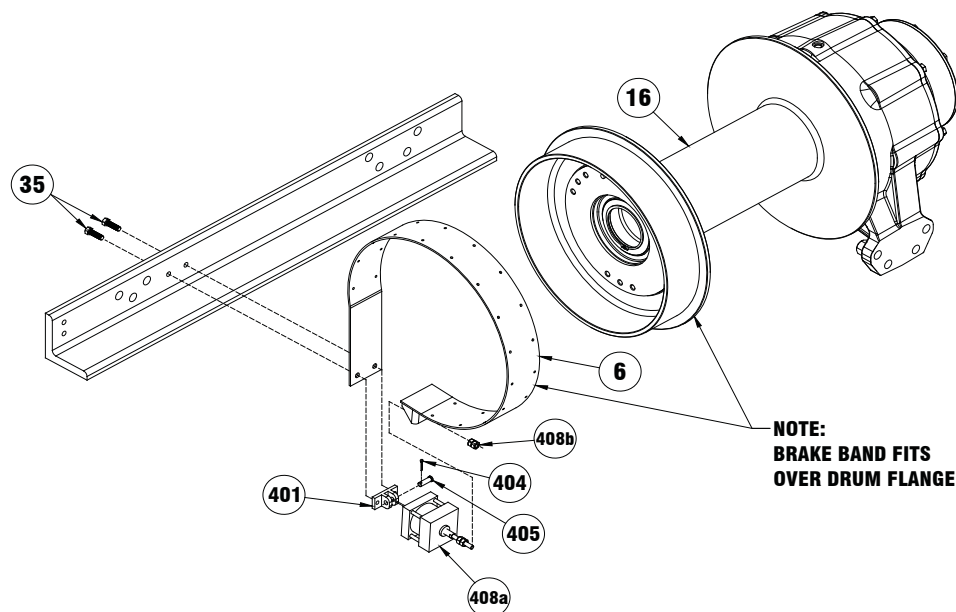

5. Remove motor #53 from winch by first disconnecting hydraulic lines (see page 17), solenoid wires, and then remove (4) bolts #36. O-ring #55 may now be removed.
6. Remove brake cover #50 by removing (4) bolts #35. The cover is spring loaded, use care when removing. Remove o-ring #54 then springs #69 may be removed; residual oil may be present in the brake housing.
7. Remove piston #13 including o-rings and backup rings #56, #57, #58, and #59 by using a momentary puff of compressed air into the brake port located on top of the end bearing. Capture the piston by placing a shop rag over the opening prior to using air.
8. Remove the sprag brake hub assembly #5, (7) stator plates #14, (6) disc brakes #15, and the spacer #25. The sprag brake hub assembly #5 is not a serviceable part, if damaged a replacement assembly should be ordered.

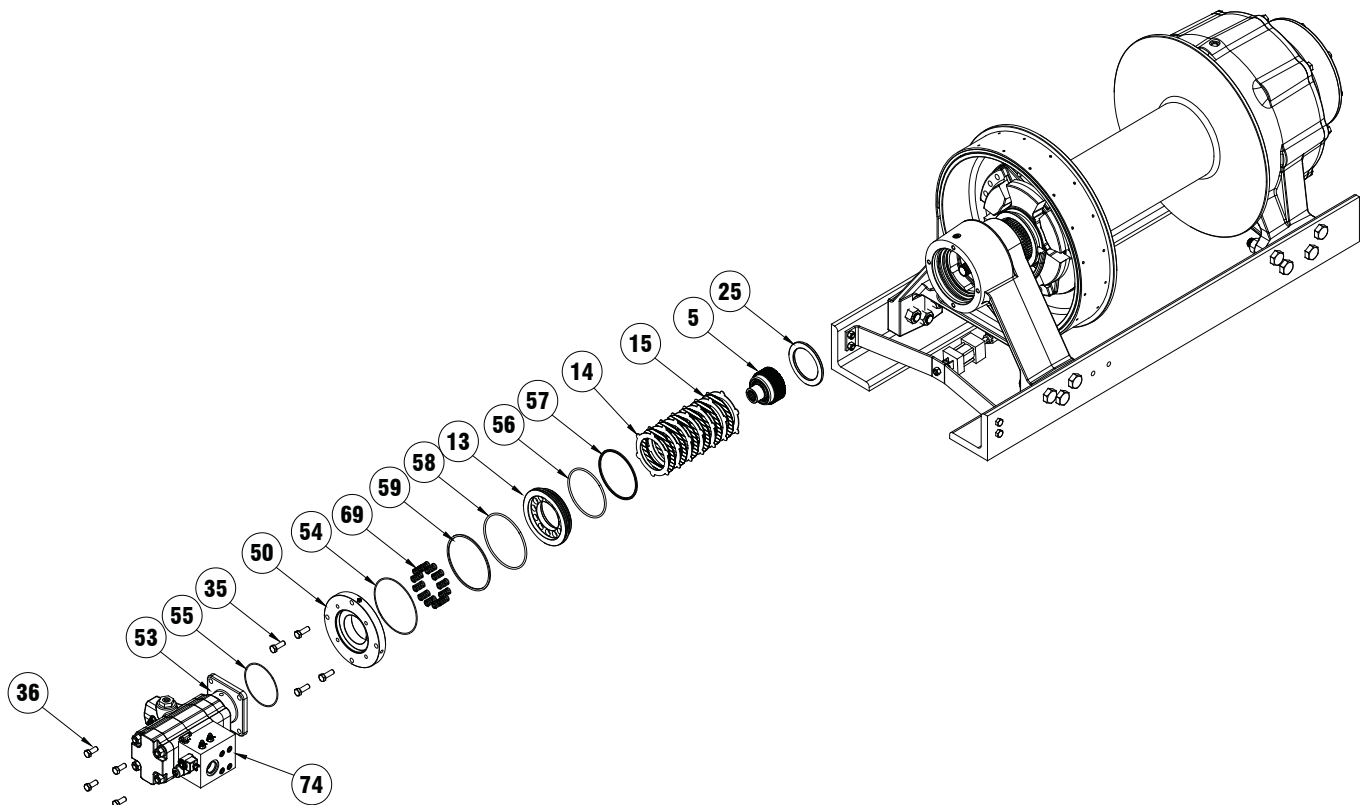

9. Remove (8) cover bolts #33, cover #12, and o-ring #60.
10. Remove snap ring #67, and sun gear #18.
11. The planetary carrier assembly #2 may now be removed along with (2) spacers #24.
12. Remove second snap ring #67 and intermediate sun gear #17 and spacer #28.
13. Planetary carrier assembly #4 may now be removed.

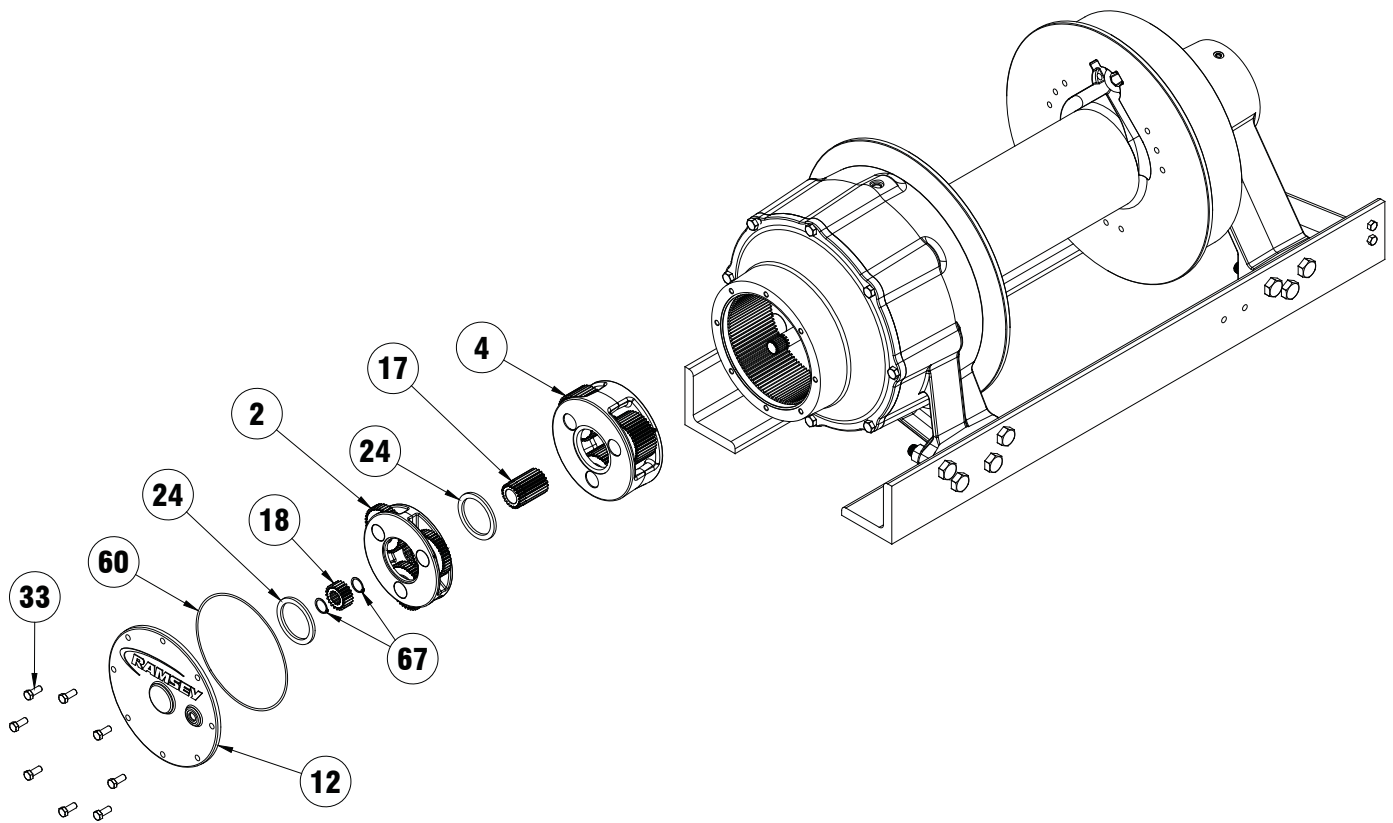

- Using a nylon strap, support ring gear #22 from a hoist or boom, this ring gear is heavy. Remove (8) bolts #37 leaving the top most bolt for last. Remove the final bolt while supporting ring gear. Set ring gear aside. Remove the o-ring #61.
- Remove spacer #28 and the output sun gear #19.

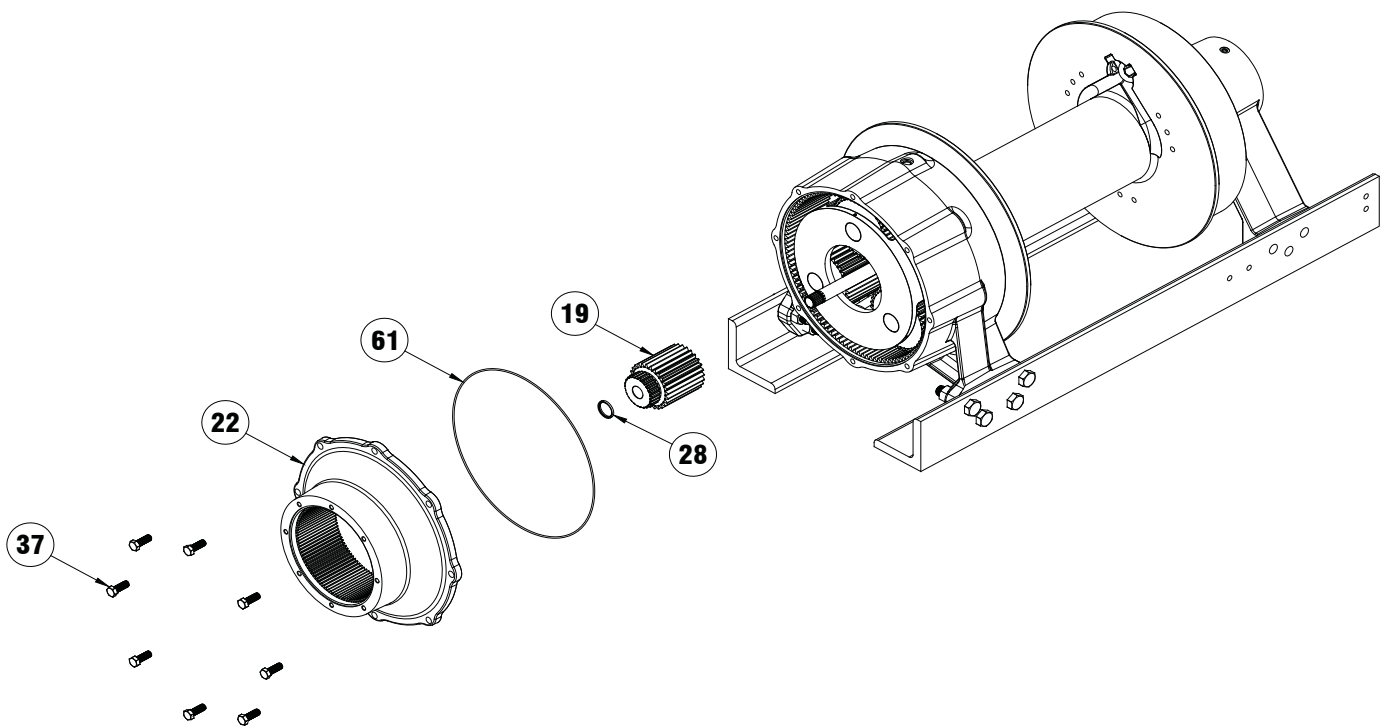

16. Remove the clutch cylinder #407 by removing the (2) cotter keys #404 and (2) pins #406 from either end of the air cylinder #407.
17. The clutch cylinder support bracket #9 can be removed by removing the four bolts #35 and nuts #41 attaching it to the mounting angles.
18. Remove the clutch yoke #29 by removing center pivot bolt #34 and nut #41.

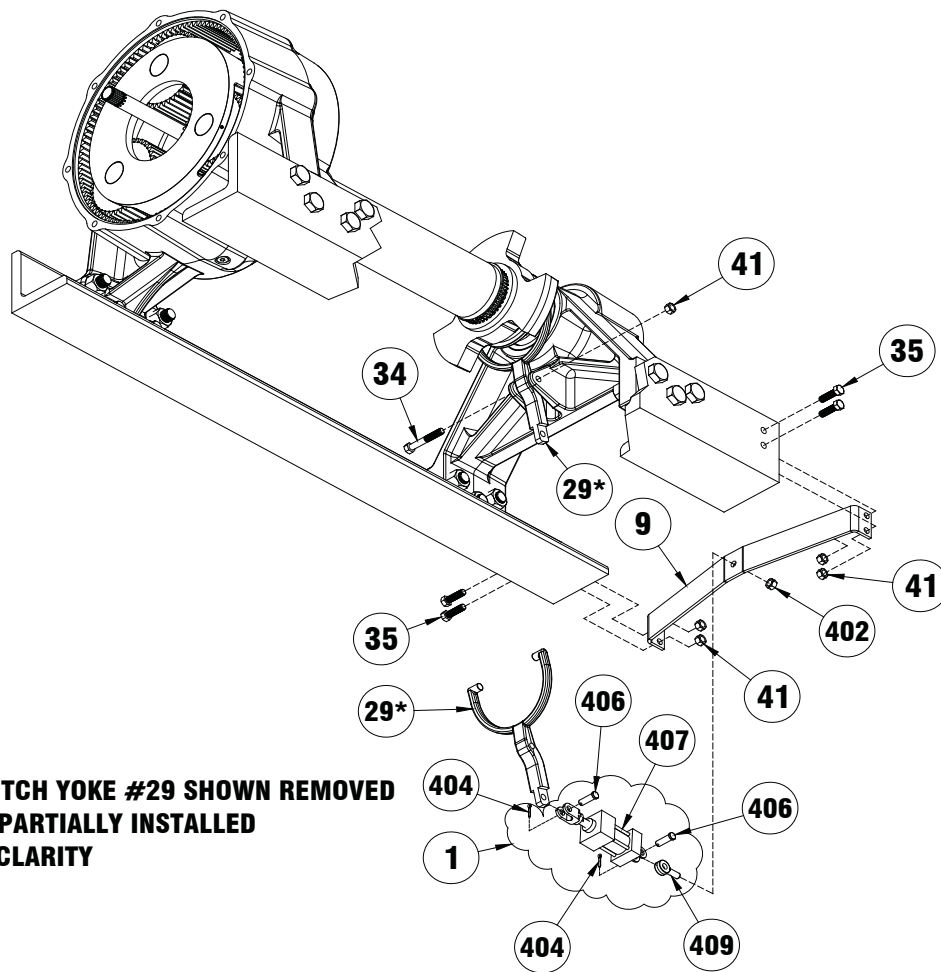

***CLUTCH YOKE #29 SHOWN REMOVED
AND PARTIALLY INSTALLED
FOR CLARITY**

19. By removing snap ring #67 and ball bearing #30, the input shaft #23 may be removed.
20. To remove the motor end bearing #20, support drum #16 with a nylon strap or chain and hoist. Lift on the drum to tension the strap. Remove (6) bolts #39 and (6) nuts #42 attaching the end bearing to the mounting angles #7 and #8. The motor end bearing #20 will be supported on the output shaft end and may be slid off using a nylon strap and hoist to lift it.

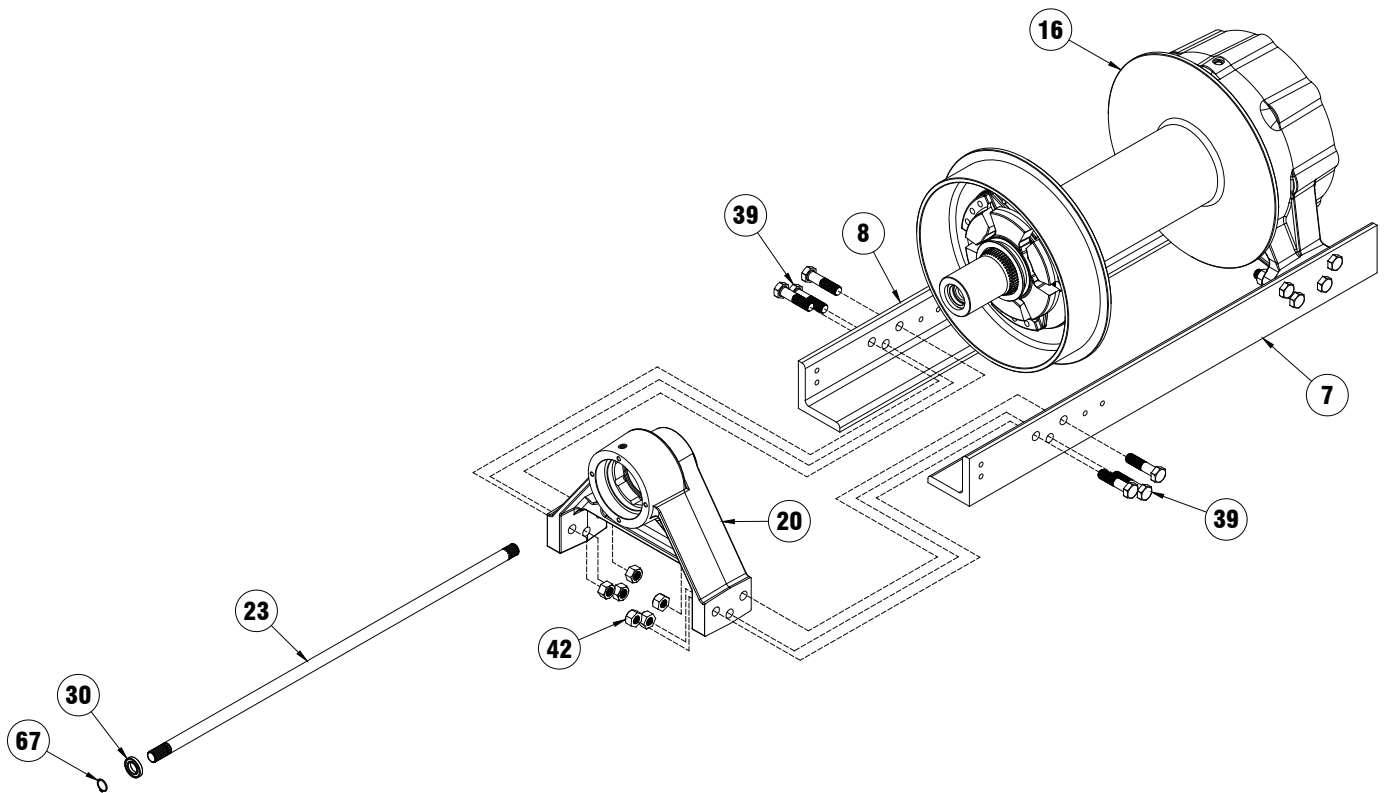

21. While continuing to support the drum #16, remove the clutch #10, snap ring #68 and spacer #26.
22. The output carrier assembly #23 may be slid from the drum assembly.
23. If required, spacer #27 can be removed from output carrier assembly.
24. The drum #14 is now supported only by the nylon strap and maybe removed as needed.
25. Remove drum driver #11 by removing (9) bolts #38.
26. The (2) bushings #31 may be pressed from the drum if replacement is necessary.

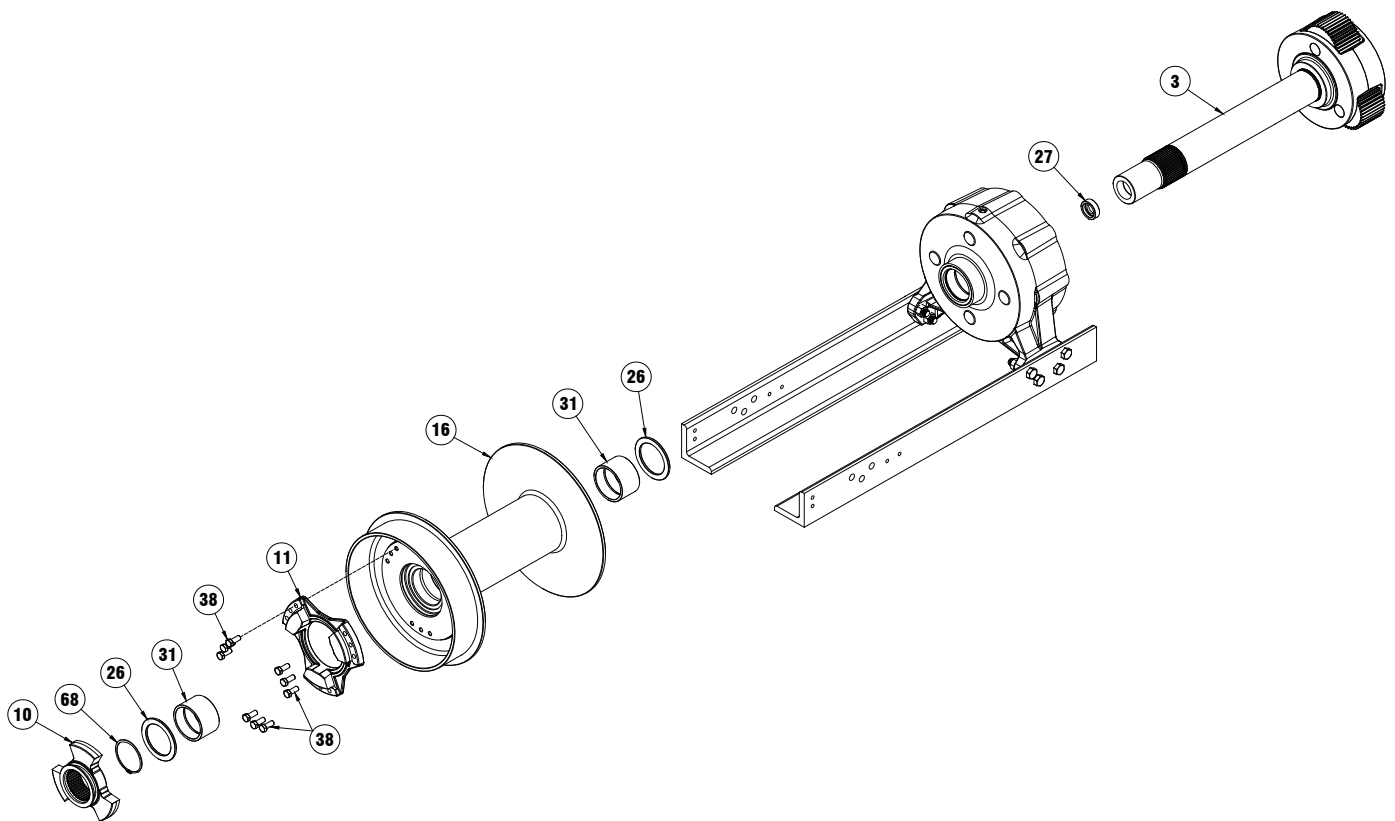

27. To remove gear end bearing #21, from mounting angles #7 and #8, first remove (4) bolts #40 and (4) nuts #42 from each angle. Shaft oil seal #66 and end bearing bushing # 31 can be removed and replaced at this time, if necessary.

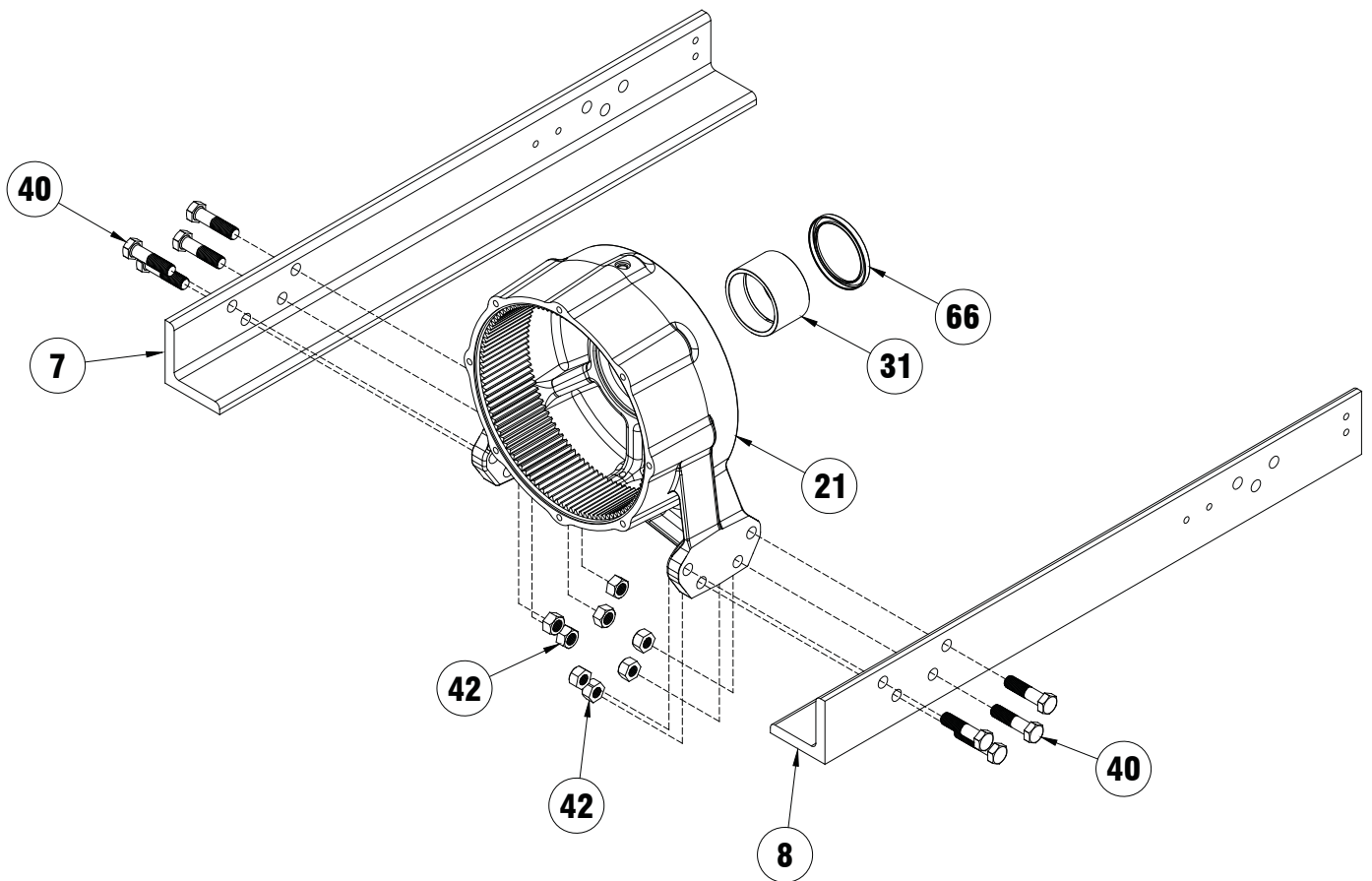

HOSE HOOKUP

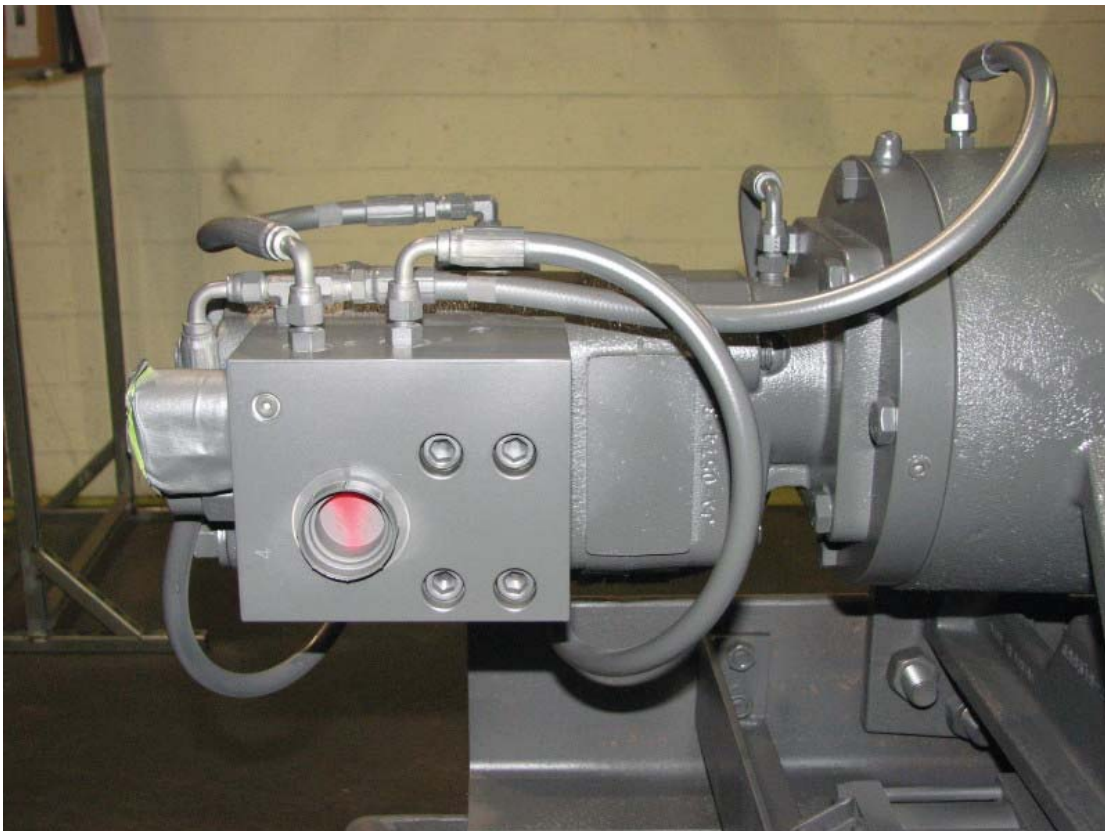
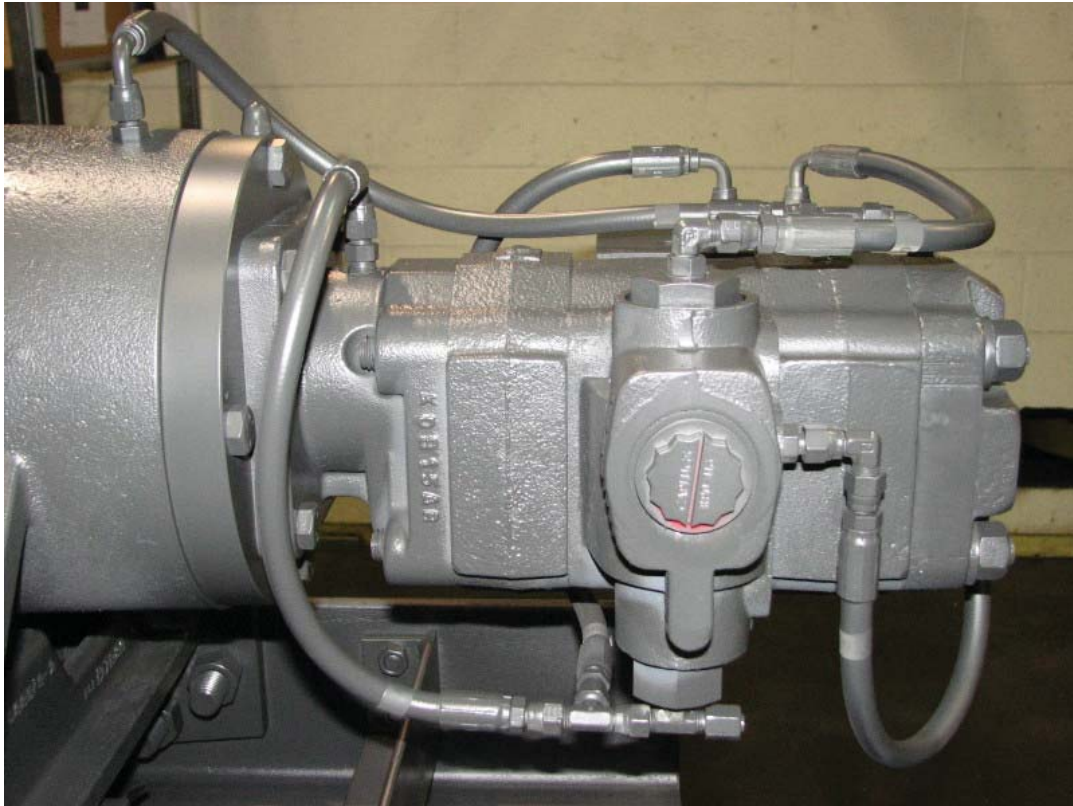

EXPLODED VIEW 105K

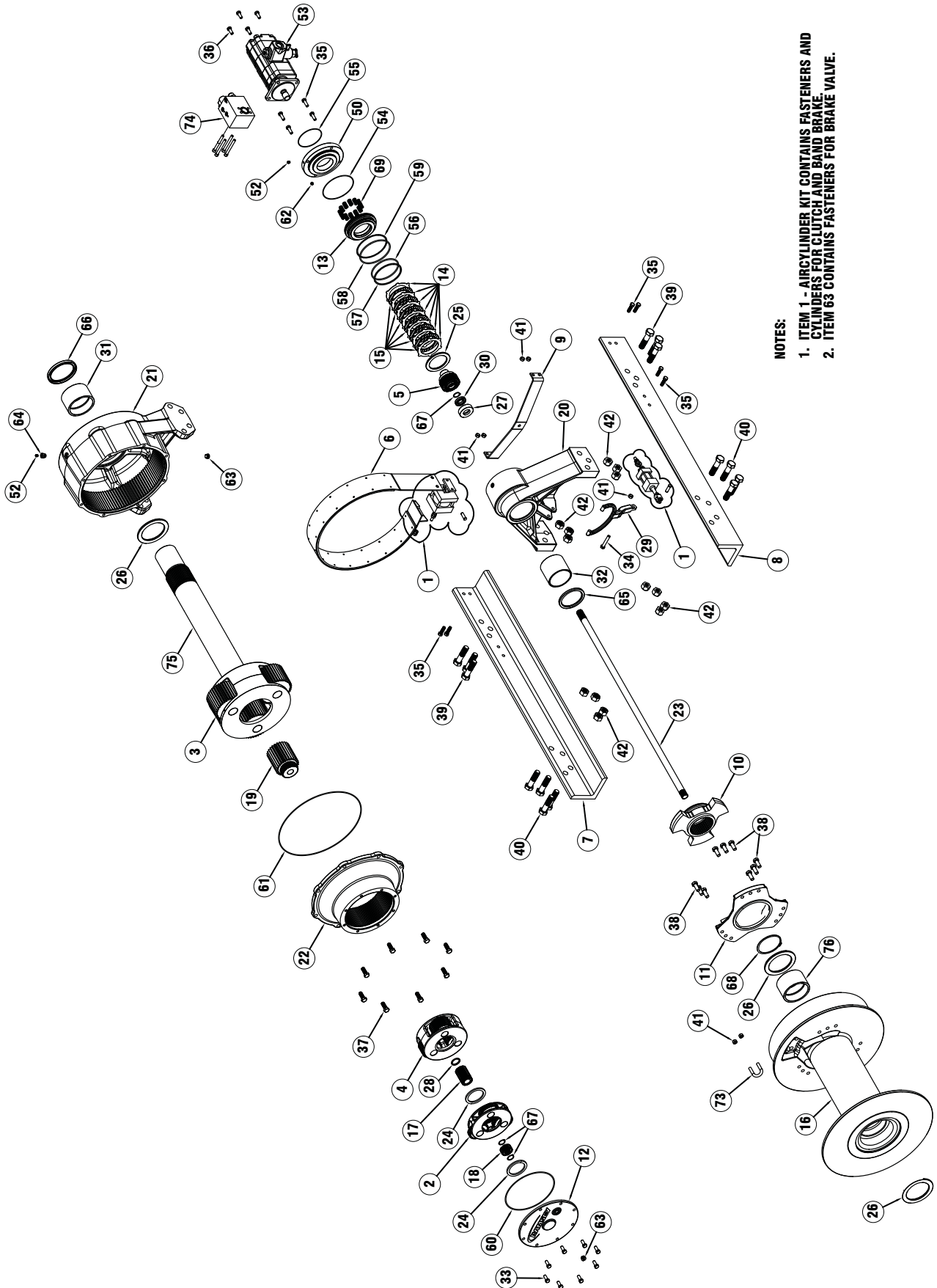

- NOTES:
1. ITEM 1 - AIRCYLINDER KIT CONTAINS FASTENERS AND CYLINDERS FOR CLUTCH AND BAND BRAKE.
 2. ITEM 63 CONTAINS FASTENERS FOR BRAKE VALVE.

PARTS LIST

ITEM	QTY	PART NO	DESCRIPTION	ITEM	QTY	PART NO	DESCRIPTION
1	1	256131	AIR CYLINDER KIT	39	6	414814	BOLT- 1-8NC X 4.5 LG, HXHD, GR8
2	1	296672	INPUT CARRIER ASSEMBLY	40	8	414815	BOLT- 1-8NC X 4 LG, HXHD, GR8
3	1	251316	OUTPUT CARRIER ASSEMBLY	41	7	418069	NUT-1/2-13NC HEX REG
4	1	296694	INTERMEDIATE CARRIER ASSEMBLY	42	14	418115	NUT-1-8NC HEX REG
5	1	296952	SPRAG BRAKE ASSEMBLY	43			NOT USED
6	1	299752	BAND BRAKE	44	1	432018	FITTING JIC O-RING EL
7	1	303160	FRAME RAIL-LH	45	4	432023	FITTING JIC O-RING NIPPLE
8	1	303161	FRAME RAIL-RH	46	1	432048	FITTING JIC SWIVEL TEE
9	1	312576	SUPPORT BRACKET, AIR CYLINDER	47	2	432049	FITTING JIC BRANCH TEE
10	1	324513	CLUTCH	48	1	432053	FITTING JIC O-RING NIPPLE
11	1	324515	DRUM DRIVER	49	1	432054	FITTING JIC SWIVEL EL
12	1	328167	COVER-GEAR END	50	1	438043	BRAKE COVER
13	1	330016	PISTON-BRAKE	51			NOT USED
14	7	330017	STATOR PLATE-BRAKE	52	2	456008	RELIEF FITTING
15	6	330018	FRICTION PLATE-BRAKE	53	1	458214	MOTOR
16	1	332254	DRUM	54	1	462063	O-RING 2-165
17	1	334199	GEAR-INTERMEDIATE SUN	55	1	462081	O-RING 2-159
18	1	334200	GEAR-INPUT SUN	56	1	462082	O-RING 2-358
19	1	334232	GEAR-OUTPUT SUN	57	1	462083	BACKUP RING 8-357
20	1	338404	BEARING SUPPORT, MOTOR END	58	1	462084	O-RING 2-362
21	1	338405	BEARING SUPPORT-GEAR END	59	1	462085	BACKUP RING 8-362
22	1	338407	RING GEAR	60	1	462092	O-Ring 2-275
23	1	357537	SHAFT-INPUT	61	1	462097	ORING 2 -284
24	2	362301	SPACER	62	1	468016	PIPE PLUG
25	1	362305	SPACER-BRAKE	63	2	468041	PLUG
26	3	362319	SPACER-OUPUT SHAFT	64	1	468042	REDUCER
27	1	362322	SPACER-BEARING	65	1	486099	OIL SEAL
28	1	362325	SPACER-INTERMEDIATE SUN GEAR	66	1	486100	OIL SEAL
29	1	370062	YOKE-CLUTCH	67	3	490006	RETAINING RING 5100-125
30	1	402132	BEARING BALL	68	1	490069	RETAINING RING 5100-500
31	1	412143	BUSHING-DRUM	69	12	494129	BRAKE SPRING
32	1	412144	BUSHING-MOTOR END	70	1	509137	HOSE
33	8	414521	CAPSCREW-1/2-13NCX1LG HXHD	71	2	509140	HOSE
34	1	414545	CAPSCREW-1/2-13NCX3.5LG,HXHD,Z/P,GR.5	72	3	509141	HOSE
35	10	414556	BOLT-1/2-13NCX1.75,HXD,GR5	73	1	514025	U-BOLT
36	4	414561	CAPSCREW-1/2-13NCX1.25 HXHD GR.5	74	1	516048	BRAKE VALVE
37	8	414658	BOLT-5/8-11NCX1.5LG,HXHD,Z/P,GR.5	75	1	357538	SHAFT-OUTPUT
38	9	414741	CAPSCREW- 3/4-10NC X 2 LG, SOCKET HEAD, ZINC	76	1	412150	BUSHING

AIR CYLINDER KIT #256131 PARTS LIST

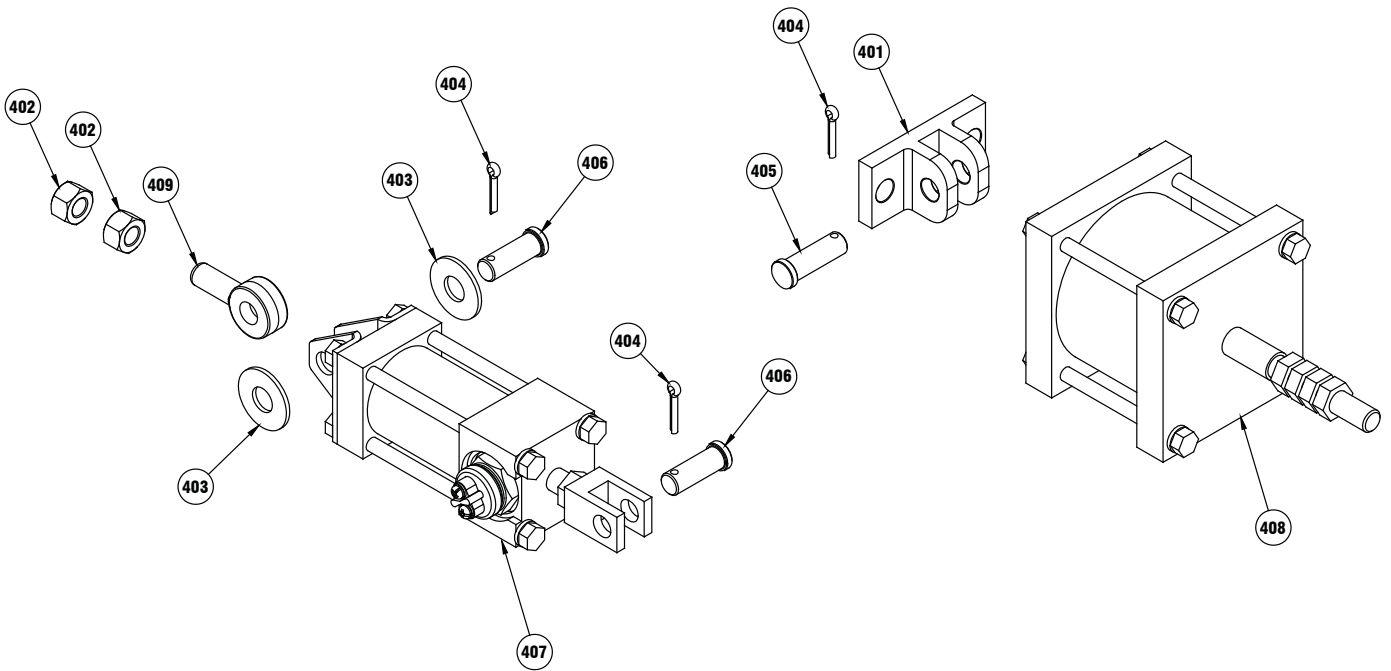

ITEM	QTY	PART NO	DESCRIPTION
401	1	408422	MOUNTING BRACKET
402	2	418067	NUT-1/2-20NF HEX JAM
403	2	418223	WASHER-1/2 USS FLAT
404	3	424005	COTTER PIN- 1/8 DIA X 1 LG
405	1	424027	CLEVIS PIN-1/2 SHAFT DIA X 1 1/2 LG
406	2	424205	CLEVIS PIN-1/2 SHAFT DIA X 1 23/64 LG
407	1	433031	AIR CYLINDER
408	1	433032	AIR CYLINDER
409	1	448108	EYE BOLT

DIMENSIONAL DRAWING WC 105K

Bolt Size (inches)	Thds Per Inch	Bolt Torque (ft-lb)	
		SAE Grade 5	SAE Grade 8
7/16	14	54	78
1/2	13	78	119
5/8	11	154	230
3/4	10	257	380
7/8	9	382	600
1	8	587	700

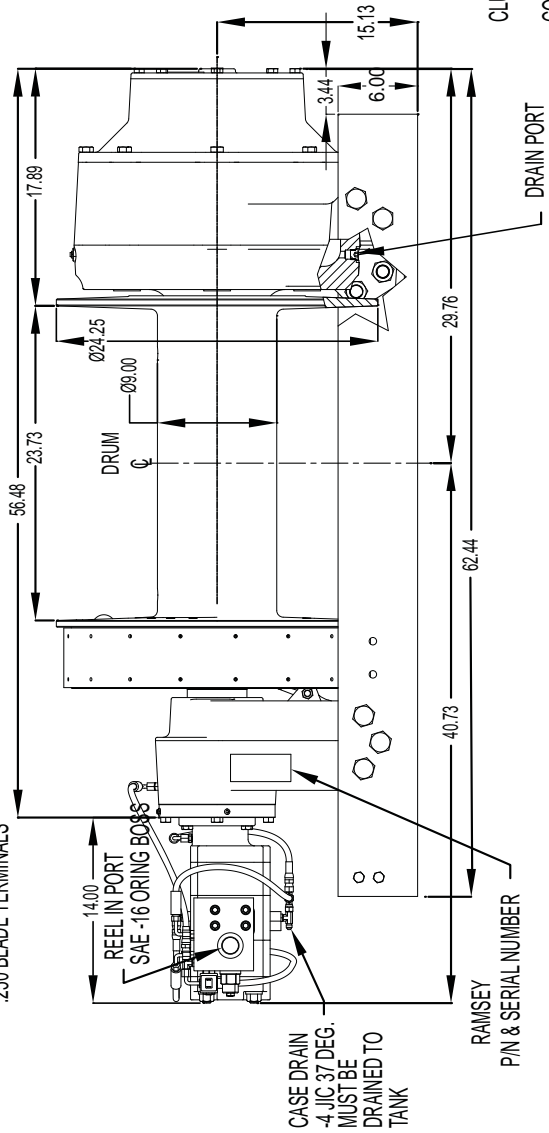
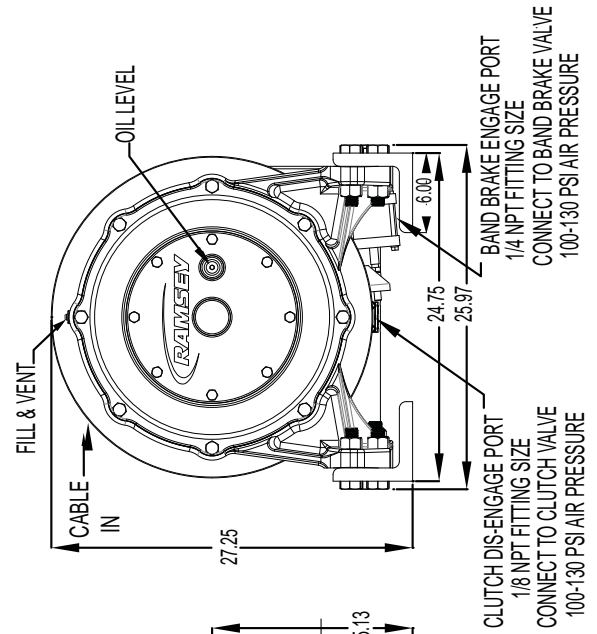
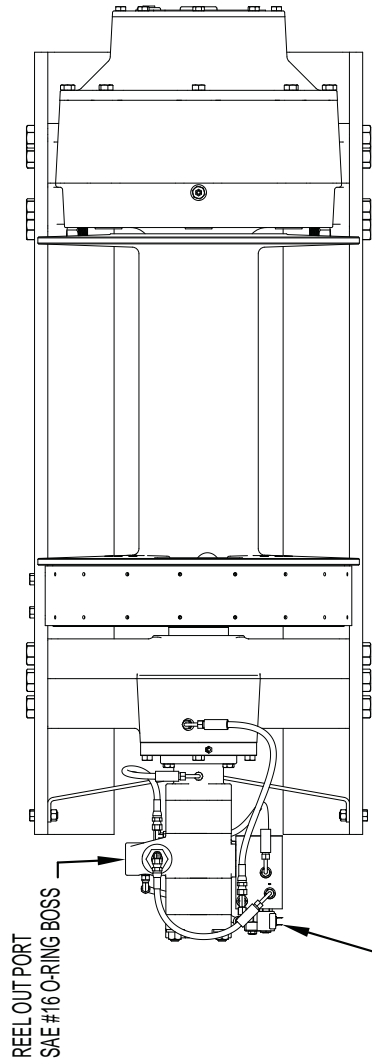

KITS AND MAINTENANCE PARTS

127254

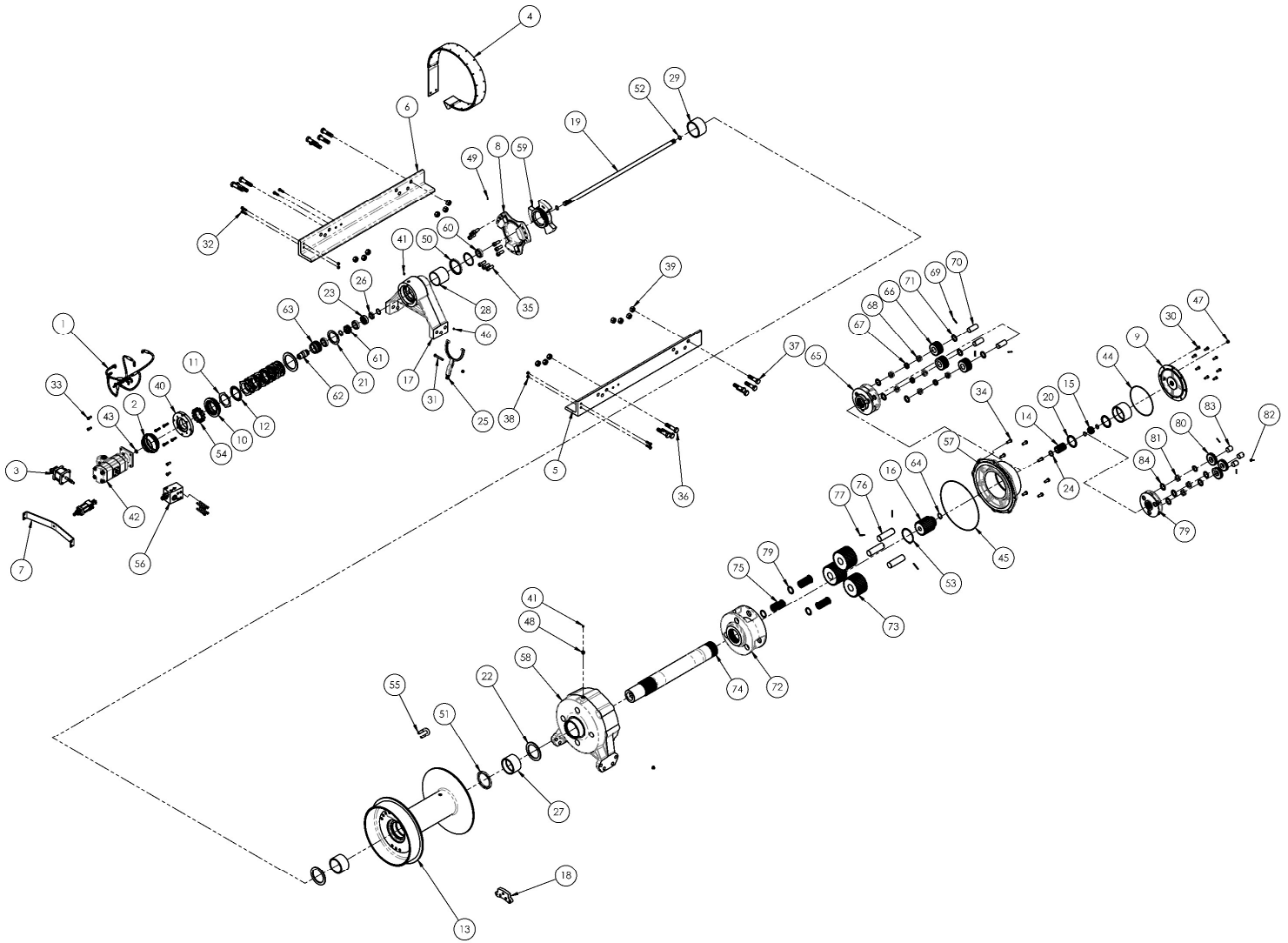

KITS AND MAINTENANCE PARTS

127254

Item#	QTY.	PART NUMBER	DESCRIPTION	KITS									
				207034	207035	207036	207037	222087	246083	246085	248073		
1	1	251284	KIT-HOSE-BRAKE VALVE										
2	1	251285	O-RING KIT										
3	1	256131	AIR CYLINDER KIT				X						
4	1	299752	BRAKE BAND				X						
5	1	303160	FRAME RAIL-LH										
6	1	303161	FRAME RAIL-RH										
7	1	312576	BRACKET-SUPPORT										
8	1	324515	CLUTCH										
9	1	328167	COVER-GEAR										
10	1	330016	PISTON -BRAKE					X					
11	7	330017	STATOR PLATE-BRAKE				X						
12	6	330018	FRICTION PLATE-BRAKE				X						
13	1	332254	DRUM										
14	1	334199	GEAR-SUN-INTERMEDIATE										
15	1	334200	GEAR-SUN-INPUT										
16	1	334232	GEAR-SUN, OUTPUT										
17	1	338404	BEARING SUPPORT										
18	1	350753	PLATE - CABLE ANCHOR										
19	1	357537	SHAFT, INPUT										
20	2	362301	SPACER-INPUT PLANETARY										
21	1	362305	SPACER-BRAKE										X
22	3	362319	SPACER-OUTPUT SHAFT										X
23	1	362322	SPACER-BEARING										X
24	1	362325	SPACER-INTERMEDIATE SUN GEAR										X
25	1	370062	CLUTCH-YOKE						X				
26	1	402132	BEARING BALL- 1-1/4X2-1/4										X
27	1	412143	BUSHING-DRUM										X
28	1	412144	BUSHING-MOTOR END										X
29	2	412150	BUSHING-DRUM										X
30	8	414521	CAPSCREW-1/2-13NCX1LG HXHD										
31	1	414545	CAPSCREW-1/2-13NCX3 1/2,HXHD,G5										
32	10	414556	BOLT-1/2-13NCX1.75,HXD,GR5										
33	4	414561	CAPSCREW-1/2-13NCX1 1/4 HXHD GR.5										
34	8	414658	BOLT-5/8-11NCX1 1/2LG,HXHDGR.5										
35	9	414741	CAPSCREW- 3/4-10NC X 2 LG, SOCKET HEAD										

KITS AND MAINTENANCE PARTS

127254

Item#	QTY.	PART NUMBER	DESCRIPTION	KITS									
				207034	207035	207036	207037	222087	246083	246085	248073		
36	6	414814	BOLT- 1-8NC X 4.5 LG, HXHD, GR8										
37	8	414815	BOLT- 1-8NC X 4 LG, HXHD, GR8										
38	5	418069	NUT-1/2-13NC HEX REG					X					
39	14	418115	NUT-1-8NC HEX REG										
40	1	438043	BRAKE COVER-WILDCAT			X							
41	2	456008	RELIEF FIT-1/8-27PFT										
42	1	458214	MOTOR-HYD, 9.64 CU. IN.										
43	2	462056	O-RING							X			
44	1	462092	O-Ring							X			
45	1	462097	ORING- 18.00ID X 18.25 OD X .125 THICK, -284							X			
46	1	468016	PIPE PLUG-1/8-27NPTF,-HEX SOC. HD										
47	2	468041	PLUG-3/4-16 (-8 SAE) WITH O-RING										
48	1	468042	REDUCER- 3/4-16 O-RING X 1/8NPTF										
49	2	470154	TAPER PIN										
50	1	486099	SEAL-OIL								X		
51	1	486100	SEAL-OIL									X	
52	3	490006	RING-RETAINER, 1 1/4										
53	2	490069	RING-RETAINER, 5.00 OD SHAFT										
54	12	494129	SPRING-BRAKE- 385LB IN/IN				X						
55	1	514023	CLIP-WIRE ROPE, 1"										
56	1	516048	COUNTER BALANCE BLOCK WC										
57	1	338407	RING GEAR- INPUT/INTERMEDIATE										
58	1	338405	BEARING SUPPORT										
59	1	324513	CLUTCH					X					
60	2	402131	BEARING-BALL-6009						X				X
61	1	402134	CLUTCH SPRAG						X				
62	1	431026	HUB-BRAKE-SHAFT					X					
63	1	431028	HUB-BRAKE-BRAKE					X					
64	2	490041	RING-RETAINER					X					
65	1	317028	CARRIER										
66	3	334204	GEAR-PLANET-INTERMEDIATE										
67	3	362307	SPACER-BEARING										X
68	204	402136	BEARING NEEDLE - 4X21.8										X
69	3	470075	PIN-1/4X 2										
70	3	470113	SHAFT-PLANETARY PIN										

KITS AND MAINTENANCE PARTS

127254

Item#	QTY.	PART NUMBER	DESCRIPTION	207034	207035	207036	207037	222087	246083	246085	248073
71	6	518067	THRUST WASHER - 1.577 X 2.341 X .118								X
72	1	317027	CARRIER-OUTPUT								
73	3	334229	GEAR-PLANET, OUTPUT								
74	1	357538	SHAFT-OUTPUT								
75	9	402144	BEARING-NEEDLE, 2.375 OD X 2.000 ID X 1.500 LG								X
76	3	470131	SHAFT-PLANET PIN, OUTPUT								
77	3	470143	PIN-SLOTTED SPRING, .25 X 2.5 LONG								
78	6	518076	WASHER-THRUST, 2.70 OD X 2.000 ID X .060 THICK								X
79	1	317018	CARRIER-INPUT								
80	3	334206	GEAR-PLANET-INPUT								
81	102	402135	BEARING NEEDLE - 4X19.8								
82	3	470105	PIN-SPRING, 3/16 X 1.625 LG								
83	3	470111	SHAFT-PLANETARY PIN-INPUT								
84	6	518067	THRUST WASHER - 1.577 X 2.341 X .118								

KITS

**RAMSEY WINCH INDUSTRIAL WINCH
LIMITED WARRANTY**

1.1 Scope of Warranty Coverage. Upon the terms and subject to the conditions set forth in this limited warranty:

- (a) RAMSEY WINCH (referred to herein as “**RAMSEY WINCH**” or the “**Manufacturer**”) warrants to each initial end user customer (a “**Purchaser**”) of a new industrial winch together with any accessories manufactured and sold directly from RAMSEY WINCH (the “**Product**”) that the Product shall be free from defects in material and workmanship, under normal working and service conditions, for a period of eighteen (18) months from the date the Product is shipped from RAMSEY WINCH. (the “**Warranty Term**”). A Purchaser shall be eligible for an additional eighteen (18) months of coverage in addition to the Warranty Term (also referred to as the “**Standard (+) PLUS benefit**”) only if the Purchaser (i) complies with Section 1.2(a) and (ii) registers the Product during the Warranty Term at myproduct.ramseywinch.com.
- (b) Notwithstanding the foregoing, this warranty does not cover components damaged by accident, abuse, misuse, neglect, untrained operators, collision, overloading, modification, disassembly, rework, misapplication, improper installation, lack of lubrication or maintenance, or improper service. This warranty does not cover the paint or material finish, rope (wire or synthetic), removal or reinstallation of the winch, or normal wear and tear and loss of functionality due to aging of the Product (which may include but is not limited to bearings, bushings, seals, O-rings, gaskets, brake material, motor brushes, electrical cables and more).

1.2 Eligibility of Warranty Coverage.

- (a) A Purchaser shall be eligible for warranty coverage under this Limited Warranty during the Warranty Term only if:
 - (i) Prior to placing a Product in service, and throughout use of the Product during the Warranty Term, the Purchaser provides (or causes to be provided) proper storage such that foreign objects (e.g. rain or debris) cannot enter any Product through entry ports which are normally closed during operation.; and
 - (ii) The Purchaser maintains, or causes to be maintained, the Product according to commercially reasonable standards and utilizes the Product for the purposes for which it was created; and
 - (iii) No repairs or alterations have been made by any party other than RAMSEY WINCH, including Purchaser, unless otherwise authorized in writing by RAMSEY WINCH.

1.3 Transferability of Warranty.

- (a) This warranty is transferable only from the Purchaser to the first subsequent transferee (the “**Transferee**”) of the Product from Purchaser upon (i) written notification to RAMSEY WINCH and (ii) registration of the transfer, both within 30 days of such Product transfer.
- (b) Upon satisfaction of transfer requirements set forth in Section 1.3(a), the Transferee shall succeed to all the rights and obligations of the Purchaser set forth in this Limited Warranty.

1.4 Certain Limitations on Scope of Warranty Service.

- (a) Any obligation of RAMSEY WINCH under this warranty, statutory or otherwise, is limited to the repair of the Product, at its factory or Authorized Service Centers. Notwithstanding the foregoing, if field service or repair is performed by RAMSEY WINCH at the request of the Purchaser and no defect is found with material or workmanship of the Product, the Purchaser shall compensate RAMSEY WINCH for its time and expenses within thirty (30) days of delivery of an invoice relating to the same. If repair is determined by RAMSEY WINCH in its sole, absolute and uncontrolled discretion to be impossible or impractical, then RAMSEY WINCH may satisfy this warranty by replacing the Product. RAMSEY WINCH will not provide any cash payment or credits for defective materials or workmanship.

- (b) Purchaser shall be responsible for any and all freight charges for any Product receiving warranty service under this limited warranty. Any travel time, transportation charges, freight charges, or similar costs incurred by RAMSEY WINCH in connection with the replacement or repair of defective parts, shall, be the responsibility of the Purchaser. If applicable, RAMSEY WINCH shall invoice Purchaser for the total amount of such charges within sixty (60) days of fulfilling its duties under this warranty, payable within thirty (30) days of delivery of such invoice. In no event shall RAMSEY WINCH be liable for bills for service, labor or other expenses that have been incurred by the Purchaser without approval or prior authorization by RAMSEY WINCH for inspection, maintenance, or repair of the Product.
- (c) If a Product is found to be operable upon inspection, the Product, at Purchaser's election, may be either (1) returned to the Purchaser with a service charge from RAMSEY WINCH for inspection, cleaning, and routine replacement of all rubber components and any other parts that show wear; or (2) RAMSEY WINCH can dispose of the product safely.

1.5 **Limitations of Liability.** RAMSEY WINCH shall in no event be liable for punitive, special or consequential damages relating to the Product or this Warranty. RAMSEY WINCH makes no warranty in respect to third-party accessories, upgrades, or additions to the Product.

1.6 **Improving Product.** RAMSEY WINCH reserves the right to improve the Product through changes in design or materials as it may deem desirable or necessary without being obligated to incorporate, upgrade, or otherwise modify previously manufactured products.

1.7 **Limitations of Warranty.**

- (a) THE WARRANTY SET FORTH ABOVE IS THE ONLY EXPRESS WARRANTY. RAMSEY WINCH HEREBY DISCLAIMS AND EXCLUDES ANY OTHER EXPRESS, IMPLIED, OR STATUTORY WARRANTIES, ARISING BY OPERATION OF LAW, COURSE OF DEALING, COURSE OF PERFORMANCE, USAGE, OF TRADE, OR OTHERWISE, INCLUDING, WITHOUT LIMITATION, ANY WARRANTIES OF MERCHANTABILITY, FITNESS FOR A PARTICULAR PURPOSE, AND INTELLECTUAL PROPERTY RIGHTS OF A THIRD PARTY.
- (b) ANY IMPLIED WARRANTY WHICH BY LAW MAY NOT BE EXCLUDED IS LIMITED IN DURATION TO ONE (1) YEAR FROM THE DATE OF ORIGINAL RETAIL PURCHASE OF THE PRODUCT.
- (c) This warranty gives you specific legal rights, and you may also have other rights which vary from jurisdiction to jurisdiction.
- (d) This warranty is valid only in the U.S.A. and Canada. For warranty outside the U.S.A. and Canada contact your nearest Ramsey Winch Distributor.

1.8 **No Modifications to Warranty.** No RAMSEY WINCH dealer, distributor, agent or employee is authorized to make any modification, extension or addition to this warranty.

1.9 **How to Apply for Warranty Coverage.**

All claims are handled by contacting your nearest Ramsey Winch Distributor. For questions, please contact customer support: rwcustomersupport@ramseyindustries.com.

Visit [Dealer Locator - Ramsey Winch](#) for Ramsey Winch Distributor locations and contact information.

Additional warranty, service support, product information, and parts information can be found on www.ramseywinch.com.

NOTES

NOTES

NOTES



Ramsey Winch Company
Post Office Box 581510
Tulsa, Oklahoma 74158-1510
Telephone: (#918) 438-2760 FAX: (#918) 438-6688