

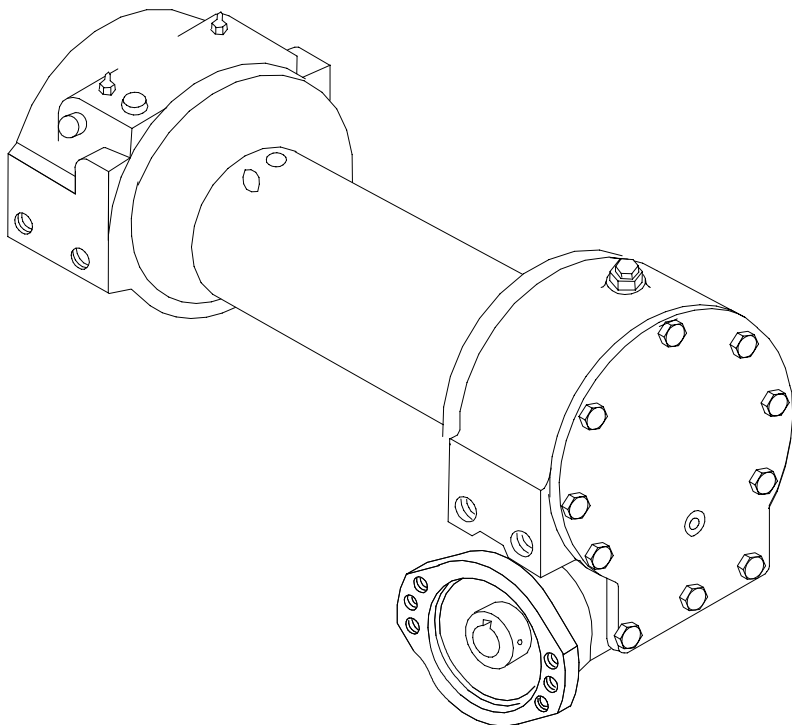

OPERATING SERVICE AND MAINTENANCE MANUAL



MODEL HD-234 LEVER STYLE INDUSTRIAL LOW-MOUNT WINCH



CAUTION: READ AND UNDERSTAND THIS MANUAL BEFORE
INSTALLATION AND OPERATION OF WINCH. SEE WARNINGS!

TABLE OF CONTENTS

INTRODUCTION	1
WARRANTY INFORMATION.....	1
SPECIFICATION	1
TECHNIQUES OF OPERATION	2
WARNINGS	2
WINCH MAINTENANCE	3
WINCH MOUNTING.....	3
CABLE INSTALLATION.....	3
HYDRAULIC SYSTEMS/PERFORMANCE CHARTS.....	4
TYPICAL LAYOUT/HYD. SYSTEM DIAGRAM	4
TROUBLE SHOOTING GUIDE.....	5
INSTRUCTIONS FOR OVERHAUL OF RAMSEY MODEL HD-234 WINCH	
DIS-ASSEMBLY	6-9
RE-ASSEMBLY	9-12
DIMENSIONAL DRAWING	13
PARTS LIST AND PARTS DRAWING.....	14-15
LIMITED WARRANTY	BACK COVER

RAMSEY WINCH MODEL HD-234

PLEASE READ THIS MANUAL CAREFULLY.

This manual contains useful ideas in obtaining the most efficient operation from your Ramsey Winch, and safety procedures one needs to know before operating a Ramsey Winch.

WARRANTY INFORMATION

Ramsey Winches are designed and built to exacting specifications. Great care and skill go into every winch we make. If the need should arise, warranty procedure is outlined on the back of your self-addressed postage paid warranty card. Please read and fill out the enclosed warranty card and send it to Ramsey Winch Company. If you have any problems with your winch, please follow instructions for prompt service on all warranty claims. Refer to back page for limited warranty.

SPECIFICATIONS: CONFORMS TO SAE J706*

Rated Line Pull	(lbs.)	8,000
	(Kg.)	3,620
Gear Reduction		34:1
Weight HD-234		110 lbs. (50 kg)
HDY-234		105 lbs. (48 kg)

LAYER OF CABLE		1	2	3	4
*Rated line pull per layer	lbs.	8,000	6,700	5,700	5,000
	Kg.	3,620	3,030	2,610	2,290
**Long Drum Cable Capacity	ft.	25	60	95	140
	m	8	18	30	43
**Short "Y" Drum Cable Capacity	ft.	15	30	55	75
	m	4	9	16	22
**Line Speed	FPM	28	34	39	44
	MPM	8,6	10,1	11,7	13,4

* Winch only conforms to SAE J706. For SAE qualifications of mounting angles, if applicable, consult Ramsey Engineering

** These Specifications are based on recommended wire rope of 3/8 inch diameter extra improved plow steel or equivalent.

NOTE: The rated line pulls shown are for the winch only. Consult the wire rope manufacturer for wire rope ratings.

TECHNIQUES OF OPERATION

The best way to get acquainted with how your winch operates is to make test runs before you actually use it. Plan your test in advance. Remember, you hear your winch, as well as see it operate. Get to recognize the sounds of a light steady pull, a heavy pull, and sounds caused by load jerking or shifting. Gain confidence in operating your winch and its use will become second nature with you.

The uneven spooling of cable, while pulling a load, is not a problem, unless there is a cable pileup on one end of drum. If this happens reverse the winch to relieve the load and move your anchor point further to the center of the vehicle. After the job is done you can unspool and rewind for a neat lay of the cable.

When pulling a load where there is even a remote chance of cable failure, place a blanket, jacket or tarpaulin over the cable about six feet behind the hook. This will slow the snap back of a broken cable and could prevent serious injury.

NOTE: The Ramsey level winder is an available accessory for tightly respooling unloaded cable onto the drum.

The winch clutch allows rapid unspooling of the cable, from cable drum, for holding onto a load. The clutch is operated by the lever located on the clutch housing of winch.

1. TO DISENGAGE CLUTCH, run the winch in the reverse (reel out) direction until load is off the cable. Grasp lever and push toward the drum to the "OUT" position. The lever is latched "OUT" by ball and detent in jaw clutch and drum shaft. The cable may now be pulled from cable drum by hand.
2. TO ENGAGE CLUTCH, pull handle away from the drum to the "IN" position, while rotating drum, until clutch jaws engage with drum jaws. Clutch must be totally engaged during winching operations. The lever is latched "IN" by ball and detent in jaw clutch and drum shaft. The plastic plug in top of clutch housing may be removed for inspection of clutch, to assure total engagement.

WARNINGS

CLUTCH MUST BE TOTALLY ENGAGED BEFORE STARTING THE WINCHING OPERATION.

DO NOT DISENGAGE CLUTCH UNDER LOAD.

STAY OUT FROM UNDER AND AWAY FROM RAISED LOADS.

STAND CLEAR OF CABLE WHILE PULLING. DO NOT TRY TO GUIDE CABLE.

DO NOT EXCEED MAXIMUM LINE PULL RATINGS SHOWN IN TABLE.

DO NOT USE WINCH TO LIFT, SUPPORT, OR OTHERWISE TRANSPORT PEOPLE.

A MINIMUM OF 5 WRAPS OF CABLE AROUND THE DRUM BARREL IS NECESSARY TO HOLD THE LOAD. SETSCREW IS NOT DESIGNED TO HOLD LOAD.

WINCH MAINTENANCE

Adhering to the following maintenance schedule will keep your winch in top condition and performing as it should with a minimum of repair.

A. WEEKLY

1. Check the oil level and maintain it to the oil level plug. If oil is leaking out, determine location and repair.
2. Check the pressure relief plug in top of the gear housing. Be sure that it is in good operating condition so that hot oil gases may escape.
3. Lubricate cable with light oil.

B. MONTHLY

1. Lubricate the various grease fittings located in the cable drum, end bearing, clutch housing, or clutch operating linkage. Any good grade of moly-disulfide containing grease is acceptable.
2. Check the action of the sliding clutch—ensure it is fully engaging and disengaging with the cable drum. To observe if the clutch is fully engaging, remove the plastic plug in top of the housing. If clutch is not fully engaging:
 - Inspect clutch shifter assembly parts, check for damage or excessive wear and replace as necessary.
 - Observe the jaws on both the clutch and cable drum, checking for rounding of the driving faces. If rounding has occurred they should be replaced immediately.
3. Check the winch mounting bolts. If any are missing, replace them and securely tighten any that are loose. Make sure to use only SAE grade 5 bolts or better.
4. Check alignment of chain and sprockets and adjust as required to minimize wear.
5. Inspect the cable. If the cable has become frayed with broken strands, replace immediately.

C. ANNUALLY

1. Drain the oil from the winch annually or more often if winch is used frequently.
2. Fill the winch to the oil level plug with clean kerosene. Run the winch a few minutes with no load in the reel in direction. Drain the kerosene from the winch.
3. Refill the winch to the oil level plug with Phillips SMP 80W-90, Mobil HD 80W-90, Shell Spirax HD 80W-90, or CITGO MP 80W-90 gear oil only.
4. Inspect frame and surrounding structure for cracks or deformation.
5. Gear wear can be estimated by rocking the drum back and forth and if necessary drain oil and remove cover for closer inspection.

WINCH MOUNTING

It is most important that this winch be mounted securely so that the three major sections (clutch housing end, cable drum, and gear housing end) are properly aligned. Refer to dimensional drawing, page 17 for mounting information.

CABLE INSTALLATION

1. Unwind cable by rolling it out along the ground to prevent kinking. Securely wrap end of cable, opposite hook, with plastic or similar tape to prevent fraying.
2. Insert the end of cable, opposite hook end, into the 7/16" dia. hole in drum barrel. Secure cable to drum barrel, using setscrew furnished with winch. **TIGHTEN SET-SCREW SECURELY.**
3. Carefully run winch in the "reel-in" direction. Keeping tension on end of cable, spool all the cable onto the cable drum, taking care to form neatly wrapped layers.

HYDRAULIC SYSTEMS

Refer to performance charts, below, to properly match your hydraulic system to the HD-234 winch performance. The charts consist of:

1. Line pull (lbs.) first layer vs. working pressure (PSI). STATIC (solid line) refers to hoisting a suspended load from rest; DYNAMIC (dashed line) refers to maintaining the motion of a moving load.
2. Line speed, first layer (FPM) vs. gallons per minute (GPM).

Performance based on a motor displacement of 3.6 cubic inches with 15 GPM maximum flow rate.

HD-234 PERFORMANCE

8,000 LB. DUTY RATING - 34:1 GEAR RATIO

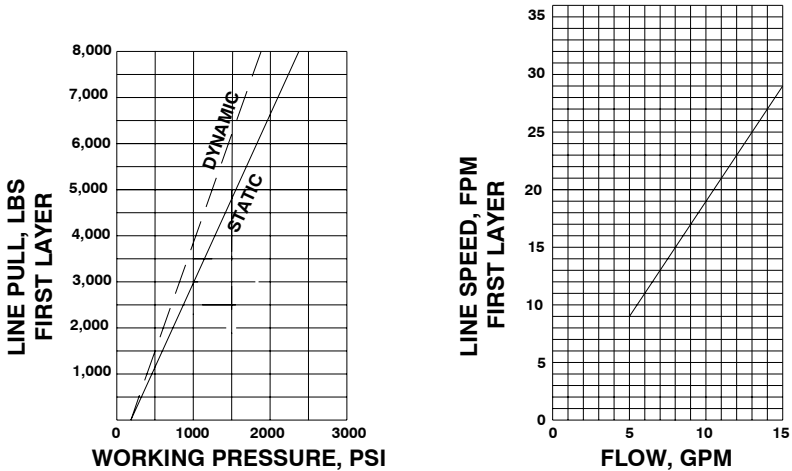

TYPICAL LAYOUT

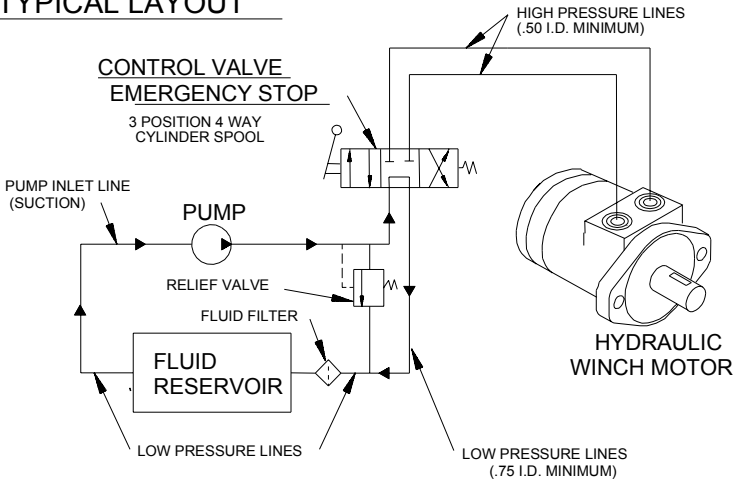

TROUBLE SHOOTING GUIDE

CONDITION	POSSIBLE CAUSE	CORRECTION
Clutch inoperative or binds up.	<ol style="list-style-type: none"> 1. Dry or rusted shaft. 2. Bent yoke or linkage. 3. Clutch jaws are in contact. 	<ol style="list-style-type: none"> 1. Clean and lubricate. 2. Replace yoke or shaft assembly. 3. See Techniques of Operation.
Oil leaks from housing	<ol style="list-style-type: none"> 1. Seal damaged or worn. 2. Too much oil. 3. Damaged gasket. 	<ol style="list-style-type: none"> 1. Replace seal. 2. Drain excess oil. Refer to Techniques of Operation. 3. Replace gasket.
Winch runs too slow	<ol style="list-style-type: none"> 1. Hydraulic motor worn out. 2. Low flow rate. 	<ol style="list-style-type: none"> 1. Replace motor. 2. Check flow rate. Refer to Hydraulic Systems flow chart, page 4.
Cable Birdnests when	<ol style="list-style-type: none"> 1. Drag brake disc worn. 	<ol style="list-style-type: none"> 1. Replace discs.
Hydraulic fluid leaks out hole in motor adapter.	<ol style="list-style-type: none"> 1. Hydraulic motor shaft seal damaged. 	<ol style="list-style-type: none"> 1. Replace seal.

INSTRUCTIONS FOR OVERHAUL OF RAMSEY

MODEL HD-234

DIS-ASSEMBLY

1. Drain oil from gear housing by removing plug (item #34) from bottom of gear housing. Remove plug and reducer (items #32 & #33) from top of gear housing.

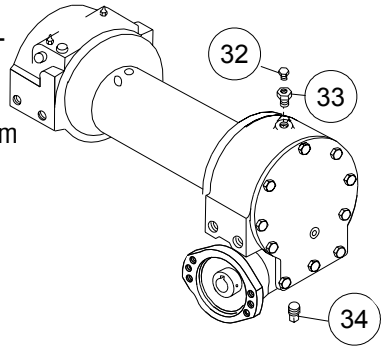

2. Remove clutch housing (item #7) and clutch (item #3) from winch assembly.
3. Remove two keys (item #29) from keyways. A screwdriver can be used, at notch, to aid in the removal of keys. Once keys have been removed, drum (item #5) and thrust washer (item #43) can be removed from drum shaft.

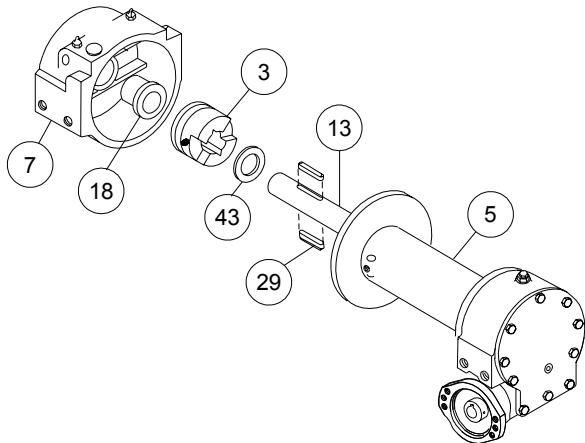

4. Remove coupling (item #34) from adapter (item #1) by unscrewing four screws (item #21).
Replace adapter seal (item #38) and gasket (item #27).

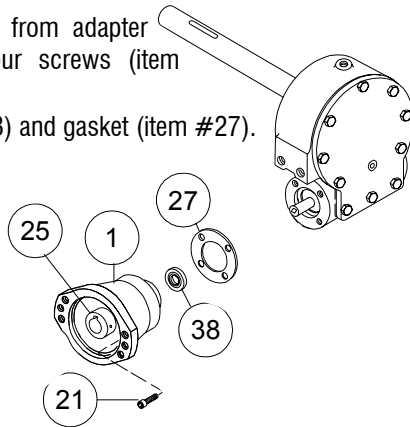

5. Remove bearing cap (item #2) from gear housing by unscrewing four capscrews (item #20). Remove worm (item #14) and bearings (item #17) from gear housing. Use soft hammer to gently tap input end of worm and drive worm and bearing from gear housing. Once worm has been removed from housing, bearing can be pressed from end of worm. Check for signs of wear or damage to worm (item #14), key (item #11), and bearing (item #17). Replace if necessary.
Drag brake disc (item #26) and spring (item #41) should be examined and replaced if necessary.

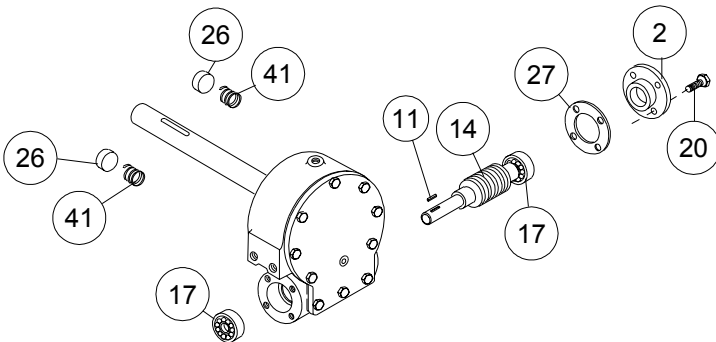

6. Remove gear housing cover (item #4) from gear housing (item #8) by unscrewing capscrews (item #20). Thread two of the capscrews into the two tapped holes of cover and tighten. This will pull the cover loose from the gear housing.

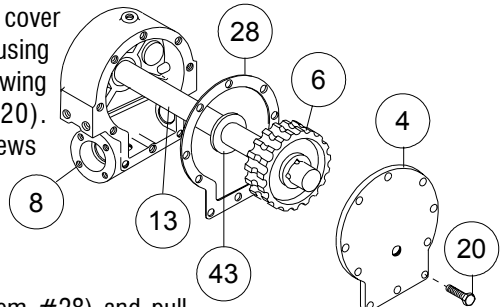

Remove cover gasket (item #28) and pull shaft (item #13), with gear attached, and thrust washer (item #43) from gear housing.

7. Check for signs of wear on gear teeth. If replacement of gear is necessary, replace as follows:

- Press gear (item #6) from shaft (item #13).
- Examine shaft keys and keyways. If distortion of keys and/or keyways is evident, shaft and keys should be replaced.

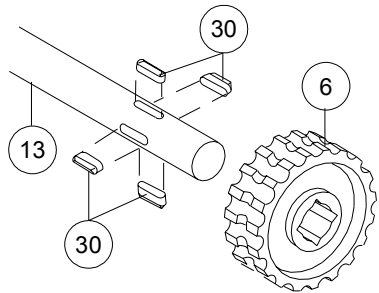

- Use a soft hammer to gently tap keys (item #30) into keyways. Press gear (item #6) over shaft and keys. Gear must be centered over keys.

8. Remove seal (item #39) from back of gear housing (item #8). Press bushing (item #19) from gear housing. Press new bushing and seal back into place.

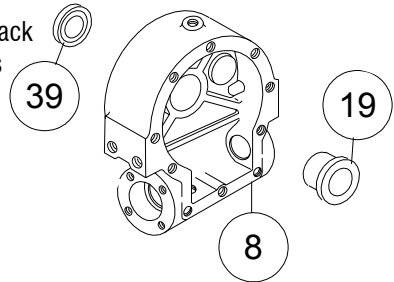

9. Check drum bushings (item #18) for signs of wear. Replace if necessary by pressing old bushings from drum. Press new ones into place.

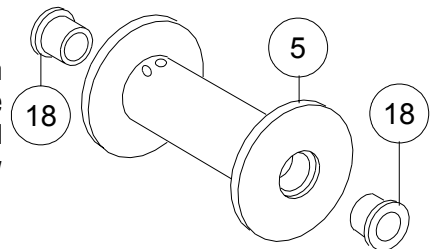

10. Check clutch housing bushing (item #20) for wear. If necessary, remove old bushing and press new bushing into place. Check yoke (item #15) for damage. Yoke should be firmly attached with set-screw (item #24). Apply grease to lube fittings (item #31) to lubricate clutch shifter shaft (item #12).

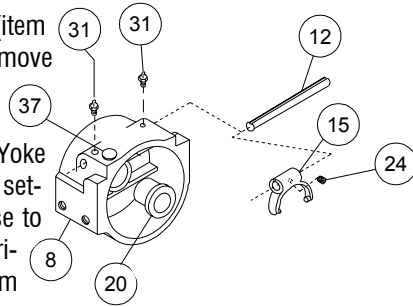

11. Check cover bushing (item #18) for signs of wear. If necessary remove old bushing and press bushing into place.

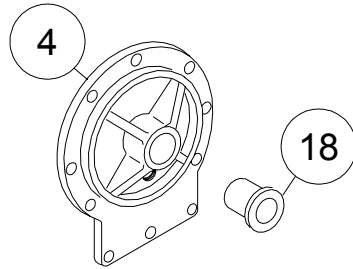

RE-ASSEMBLY

12. Apply grease to end of shaft, opposite gear. Apply grease to bushing in gear housing (item #8). Place greased end of shaft through thrust washer (item #42) and bushing in gear housing. Place gasket (item #28) onto gear housing cover (item #4). Apply grease to gear end of shaft and cover bearing. Place cover onto shaft and secure to housing with ten cap-screws (item #20). **Tighten capscrews to 8 ft-lbs. (10.8 Nm) each.**

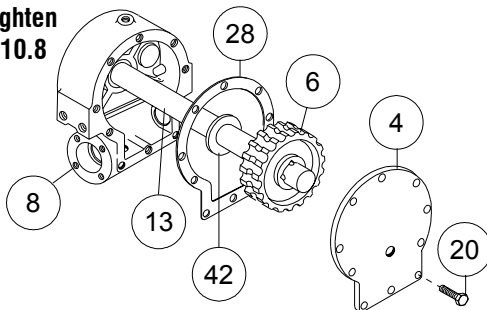

13. Press bearing (item #17) onto worm (item #14) *Note: Be sure that thick shoulder of bearing's outer race (side with manufacturer's name and part number) is out, away from worm threads.* Tap key (item #11) into worm. Press bearing and worm into gear housing. Slip gasket (item #27) onto bearing cap (item #2). Use four capscrews (item #20) to secure cap to gear housing. **Tighten capscrews to 8 ft-lbs. (10.8 Nm) each.**

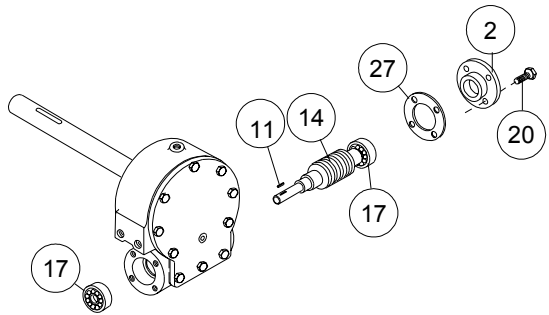

14. Press bearing (item #17) onto worm and into gear housing. *Note: Be sure that thick shoulder of bearing's outer race (side with manufacturer's name and part number) is out, away from worm threads.*

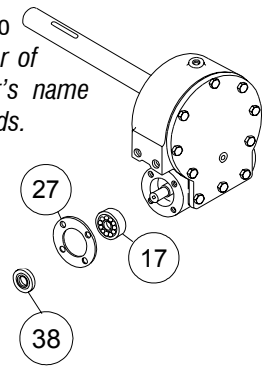

15. Place gasket (item #27) onto adapter (item #1). Slide seal (item #38) onto worm. Slide tapered end of coupling (item #25) over end of worm shaft. Attach adapter and coupling to gear housing using four screws (item #21). Tighten screws to 12 ft-lbs. (16.3 Nm) each.

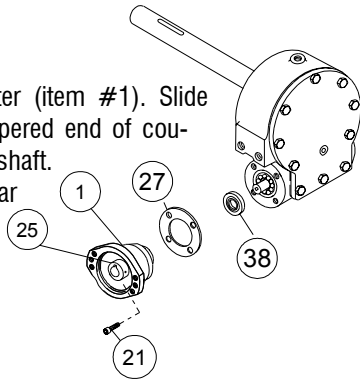

16. Place winch with gear housing cover down on work bench. Drum shaft should be in vertical position. Slide thrust washer (item #42) over drum shaft and slide downward until washer rests on gear housing. Set springs (item #41) into pockets of gear housing with drag brakes (item #26) on top of springs. Slide drum assembly (item #5) onto drum shaft with drum jaws upward.

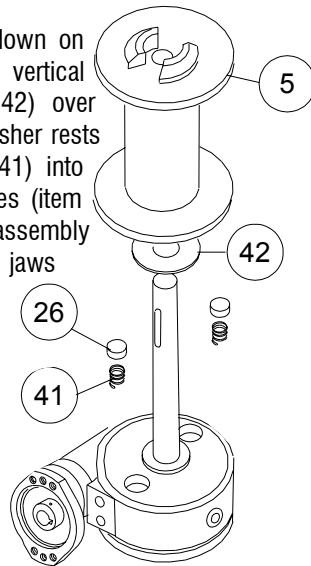

17. Place thrust washer (item #43) over end of drum shaft and slide downward until space rests on drum. Press drum downward to compress springs in gear housing.

Insert keys (item #29) into keyways with sharp edge of keys pointing outward and notched end of keys upward. A rubber or brass mallet will be needed to gently tap keys into position.

Apply grease to keys and end of shaft. Place jaw clutch (item #3) over end of shaft and slide jaw clutch over keys.

Set clutch housing (item #7) over end of drum shaft. Pull jaw clutch (item #3) upward, toward clutch housing, enough to allow yoke, in clutch housing, to fit properly in groove around jaw clutch.

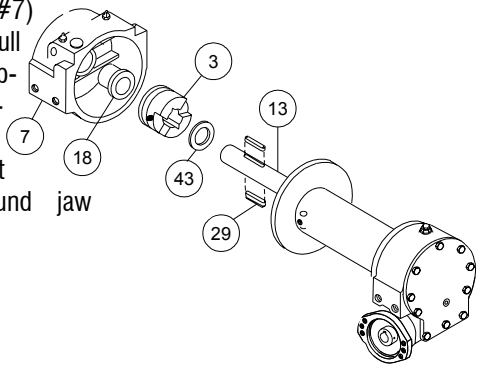

18. Insert plug (item #34) into bottom of gear housing. Permatex may be applied to threads to help prevent leakage.

Pour 3/4 pint of **Phillips SMP 80W-90, Mobil HD 80W-90, Shell Spirax HD 80W-90, or CITGO MP 80W-90 gear oil only** into housing through hole in top of housing. Insert relief fitting (item #32) into reducer (item #33). Reducer should then be placed into hole on top of gear housing. Tighten fitting and reducer securely.

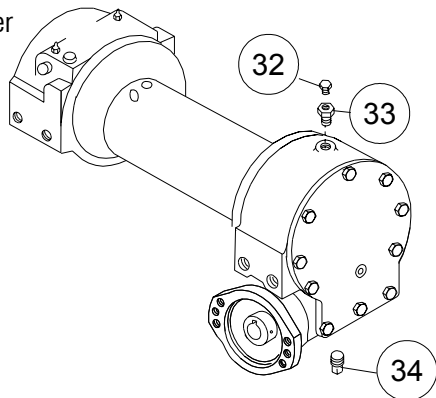

NOTES

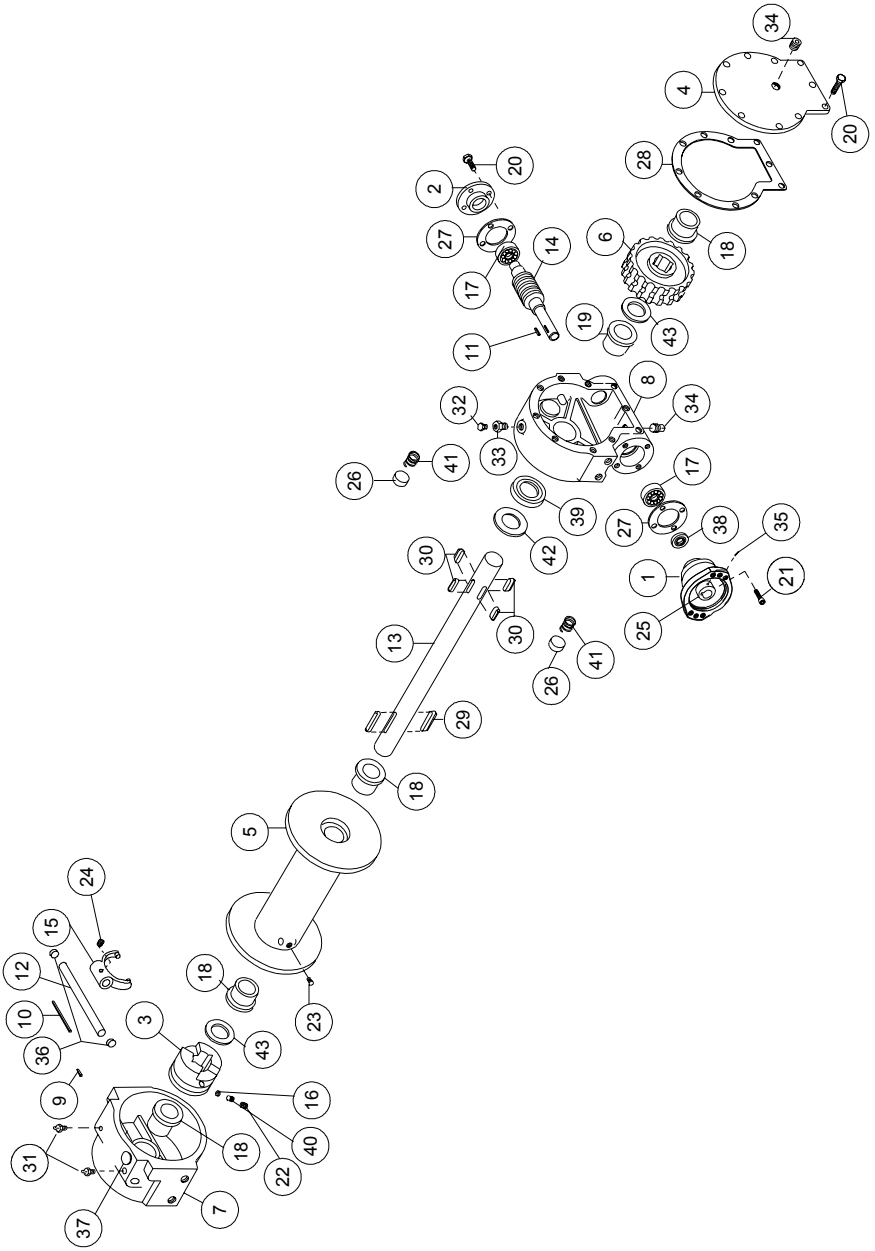

PARTS LIST MODEL HD-234 LEVER STYLE

Item No.	Qty.	Parts No.	Description	Item No.	Qty.	Parts No.	Description
1	1	300057	ADAPTER	22	1	416040	SETSCREW - 5/16-18NC X 1/4 HX SOC HD
2	1	316083	BEARING CAP	23	1	416059	SETSCREW - 3/8-16NC X 1/2 HX SOCK HD CUP
3	1	324161	CLUTCH - JAW	24	1	416084	SETSCREW - 1/4-20NC X 1/2 SQHD CUP
4	1	328134	COVER	25	1	431008	COUPLING - HYDRAULIC MOTOR
5	1	332105	DRUM - STD	26	2	438014	DISC BRAKE
6	1	334183	GEAR - R.H. WORM	27	2	442184	GASKET
7	1	338003	CLUTCH HOUSING	28	1	442205	GASKET
8	1	338273	GEAR HOUSING	29	2	450006	KEY
9			NOT USED	30	4	450016	KEY
10	1	342024	KEY	31	2	456006	FITTING - LUBRICATION
11	1	342027	KEY	32	1	456008	RELIEF FITTING
12	1	356902	SHIFTER SHAFT	33	1	468002	REDUCER
13	1	357479	DRUM SHAFT	34	2	468011	PIPE PLUG
14	1	368203	WORM - R.H.	35	1	470033	SPIROL PIN
15	1	370055	YOKE	36	1	472006	PLASTIC CAP
16	1	400001	BALL POPPET	37	1	472013	PLUG
17	2	402002	BEARING	38	1	486009	OIL SEAL
18	4	412003	BUSHING	39	1	486017	OIL SEAL
19	1	412045	BUSHING	40	1	494001	SPRING POPPET
20	14	414045	CAPSCREW - 1/4-20NC X 3/4 HX HD GR5 ZIP	41	2	494002	SPRING
21	4	414842	SCREW - 1/4-20NC X 1 1/4 HX SOC	42	1	518014	THRUST WASHER
				43	2	518015	THRUST WASHER

KITS AND MAINTENANCE PARTS

121576

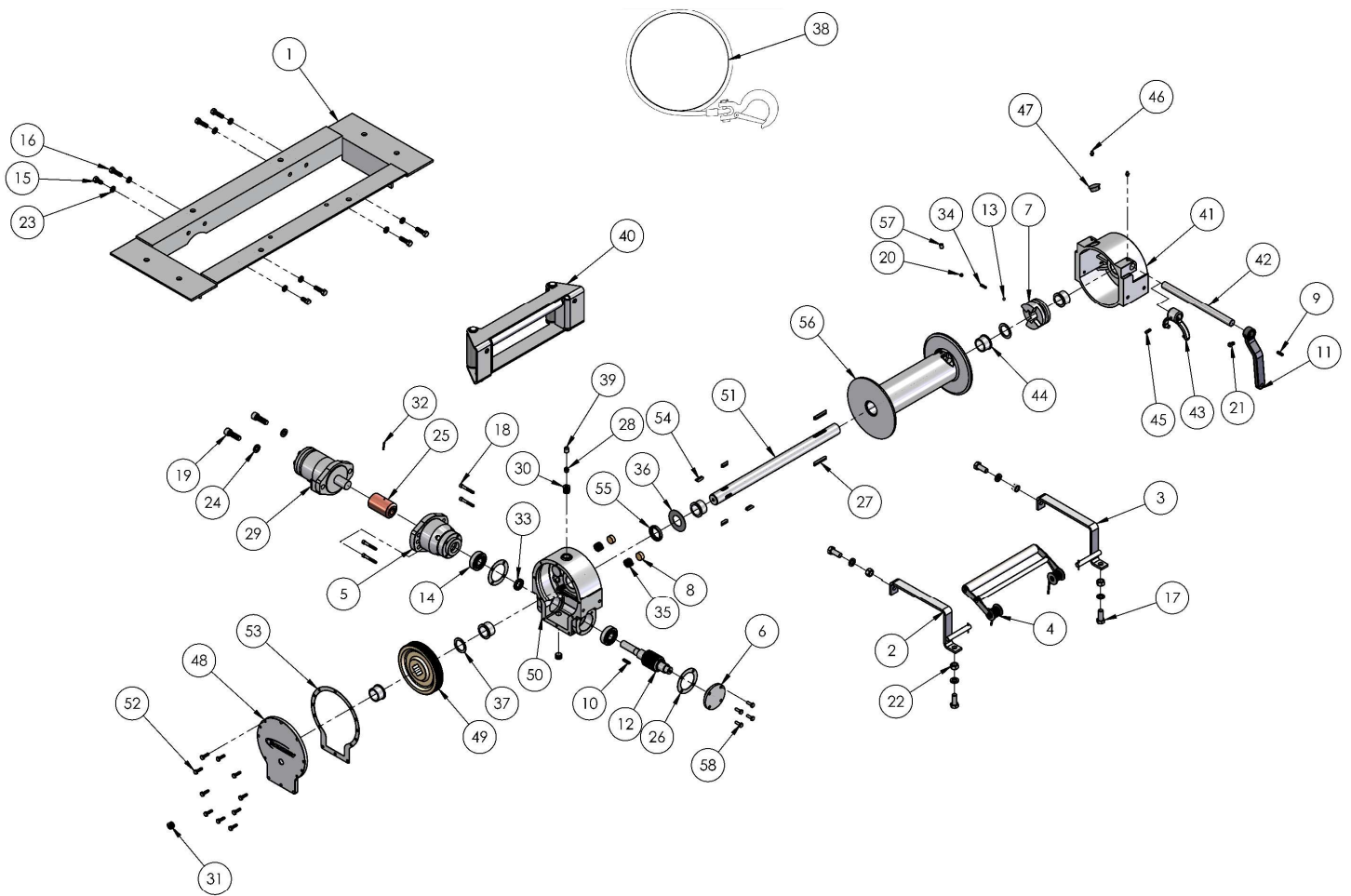

KITS AND MAINTENANCE PARTS

121576

Item#	QTY.	PART NUMBER	DESCRIPTION	KITS					
				207031	222051	246040	248055	250507	283081
1	1	242183	WELDMENT-FRAME						
2	1	265127	WELDMENT-BRACKET, LEFT TENS/FRLD SUPPORT						
3	1	265128	WELDMENT-BRACKET, RIGHT TENS/FRLD SUPPORT						
4	1	299772	ASSEMBLY-ROLLER SPRING TENSIONER						
5	1	300057	ADAPTER						
6	1	316083	CAP-BRG						
7	1	324161	JAW CLUTCH		X				
8	2	330010	SHOE-DRAG BRK,7/8DIA X3/8LG	X					
9	1	342024	KEY-SQ END 3/16X3/16X3/4LG		X				
10	1	342027	KEY-RD ENDS,3/16X3/16X1LG						X
11	1	344008	LEVER-CLUTCH		X				
12	1	368203	WORM-RH DL						
13	1	400001	BALL-POPPET,1/4DIA		X				
14	2	402002	BEARING-BALL					X	
15	2	414279	CAPSCREW-3/8-16NCX3/4 LG,HXHD,GR-5						
16	6	414282	CAPSCREW-3/8-16NCX1 1/4LG,HXHD GR-5						
17	6	414578	CAPSCREW-1/2-13NCX1 1/4,HXHD,GR5						
18	4	414842	CAPSCREW-1/4-20NCX1 3/4,HXSOC						
19	2	414952	CAPSCREW-1/2-13NCX1 1/2LG,SOCHD						
20	1	416040	SETSCREW-5/16-18NCX1/4LG HXSOCHD		X				
21	1	416109	SETSCREW-5/16-18NCX1/2 SQ HD						
22	6	418069	NUT-1/2-13NC HEX REG						
23	8	418177	LOCKWASHER-3/8 MED SECT						
24	8	418218	LOCKWASHER-1/2 ID						
25	1	431008	COUPLING						X
26	2	442184	GASKET-BRG CAP			X		X	
27	2	450006	KEY-BARTH,5/16X1 7/8LG						
28	1	456008	RELIEF FIT-1/8-27PFT						
29	1	458111	MOTOR, 3.6 CID						
30	1	468002	RED-3/8-1/8NPTF GEN						
31	2	468018	PIPE PLUG-3/8-18NPTF HXSOCHD						
32	1	470033	SPIROL PIN-1/8X7/8						X
33	1	486009	OIL SEAL-RL			X		X	
34	1	494001	SPRING		X				
35	2	494002	SPRING-QQ-W-428	X					
36	1	518014	THRUST WASHER-1/32				X		
37	2	518015	THRUST WASH				X		
38	1	524184	ASSEMBLY-WIRE ROPE, 3/8 X 50', 6 X 25						

KITS AND MAINTENANCE PARTS

121576

				KITS					
Item#	QTY.	PART NUMBER	DESCRIPTION	207031	222051	246040	248055	250507	283081
39	1	530069	COVER-VENT PLUG						
40	1	530182	ROLLER FAIRLEAD ASSEMBLY						
41	1	338003	HOUSING-TENZALOY CASTING						
42	1	356996	SHAFT-SHIFTER		X				
43	1	370055	YOKE-CLUTCH		X				
44	5	412045	BUSHING				X		
45	1	416084	SETSCREW-1/4-20NCX1/2 SQHD		X				
46	1	456006	FITTING-LUBE, 1/4-28 TAPER						
47	1	472013	PLUG-PLAST,1DIA						
48	1	328134	COVER-GEAR HSG						
49	1	334183	WORM GEAR - RH					X	
50	1	338273	HOUSING-GEAR						
51	1	357479	SHAFT-DRUM					X	
52	10	414045	CAPSCREW-1/4-20NCX7/8 LG. HEX HD, GR 5						
53	1	442205	GASKET-GH CVR			X		X	
54	4	450016	KEY-BARTH,5/16X 15/16L					X	
55	1	486017	OIL SEAL			X		X	
56	1	332105	DRUM						
57	1	416059	SETSCREW3/8-16NCX1/2 HX SOCK HD						
58	4	414038	CAPSCREW-1/4-20NCX3/4,HXHD,GR-5						

KITS AND MAINTENANCE PARTS

121786

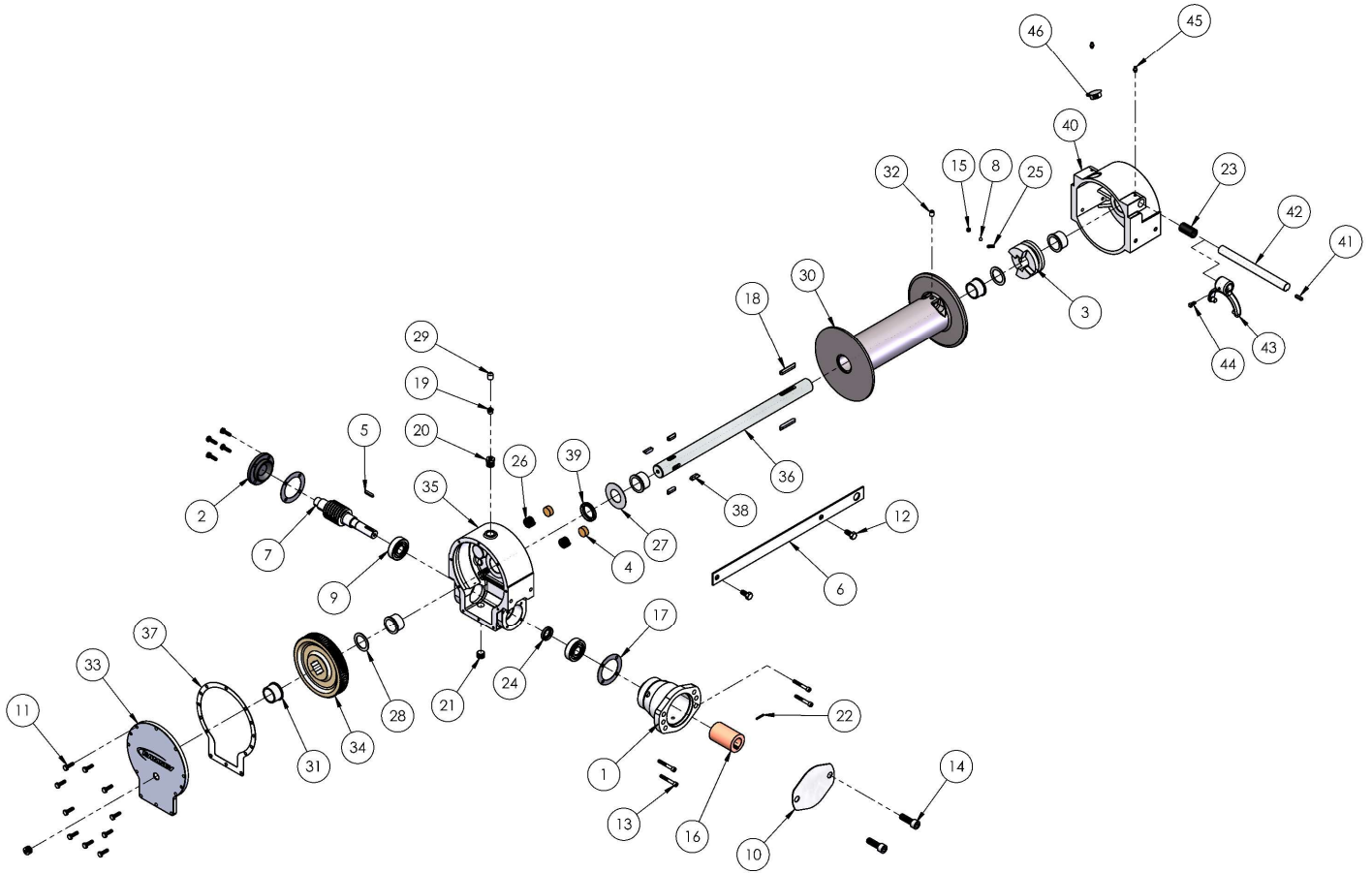

KITS AND MAINTENANCE PARTS

121786

Item#	QTY.	PART NUMBER	DESCRIPTION	KITS					
				207031	222054	246040	248055	250507	283081
1	1	300057	ADAPTER						
2	1	316083	CAP-BRG						
3	1	324161	JAW CLUTCH		X				
4	2	330010	SHOE-DRAG BRK,7/8DIA X3/8LG	X					
5	1	342027	KEY-RD ENDS,3/16X3/16X1LG						X
6	1	364145	STRAP-SHIP,1/8X1 1/4X19LG,H200,J.D.						
7	1	368203	WORM-RH DL, HD 234						
8	1	400001	BALL-POPPET,1/4DIA		X				
9	2	402002	BEARING-BALL					X	
10	1	413013	COVER-HYD ADP						
11	14	414045	CAPSCREW-1/4-20NCX7/8 LG. HEX HD, GR 5						
12	2	414279	CAPSCREW-3/8-16NCX3/4 LG,HXHD,GR-5						
13	4	414842	CAPSCREW-1/4-20NCX1 3/4,HXSOC						
14	2	414952	CAPSCREW-1/2-13NCX1 1/2LG,SOCHD						
15	1	416040	SETSCREW-5/16-18NCX1/4LG HXSOCHD		X				
16	1	431008	COUPLING						X
17	2	442184	GASKET			X		X	
18	2	450006	KEY-BARTH,5/16X1 7/8LG						
19	1	456008	RELIEF FIT-1/8-27PFT						
20	1	468002	RED-3/8-1/8NPTF						
21	2	468018	PIPE PLUG-3/8-18NPTF HXSOCHD						
22	1	470033	SPIROL PIN-1/8X7/8						X
23	1	472006	CAP-PLAST		X				
24	1	486009	OIL SEAL-RL			X		X	
25	1	494001	SPRING		X				
26	2	494002	SPRING	X					
27	1	518014	THRUST WASHER-1/32				X		
28	2	518015	THRUST WASH				X		
29	1	530069	COVER-VENT PLUG						
30	1	332105	DRUM						
31	5	412045	BUSHING-GH				X		
32	1	416059	SETSCREW3/8-16NCX1/2 HX SOCK HD						
33	1	328134	COVER-GEAR HSG						
34	1	334183	WORM GEAR - RH					X	
35	1	338273	HOUSING-GEAR						
36	1	357479	SHAFT-DRUM					X	
37	1	442205	GASKET-GH			X		X	
38	4	450016	KEY-BARTH,5/16X 15/16L					X	

KITS AND MAINTENANCE PARTS

121786

				KITS					
Item#	QTY.	PART NUMBER	DESCRIPTION	207031	222054	246040	248055	250507	283081
39	1	486017	OIL SEAL			X		X	
40	1	338003	HOUSING-TENZALOY CASTING						
41	1	342024	KEY-SQ END 3/16X3/16X3/4LG		X				
42	1	356902	SHAFT-SHIFT		X				
43	1	370055	YOKE-CLUTCH		X				
44	1	416084	SETSCREW-1/4-20NCX1/2 SQHD		X				
45	2	456006	FITTING-LUBE, 1/4-28						
46	1	472013	PLUG-PLAST,1DIA						

KITS AND MAINTENANCE PARTS

121787

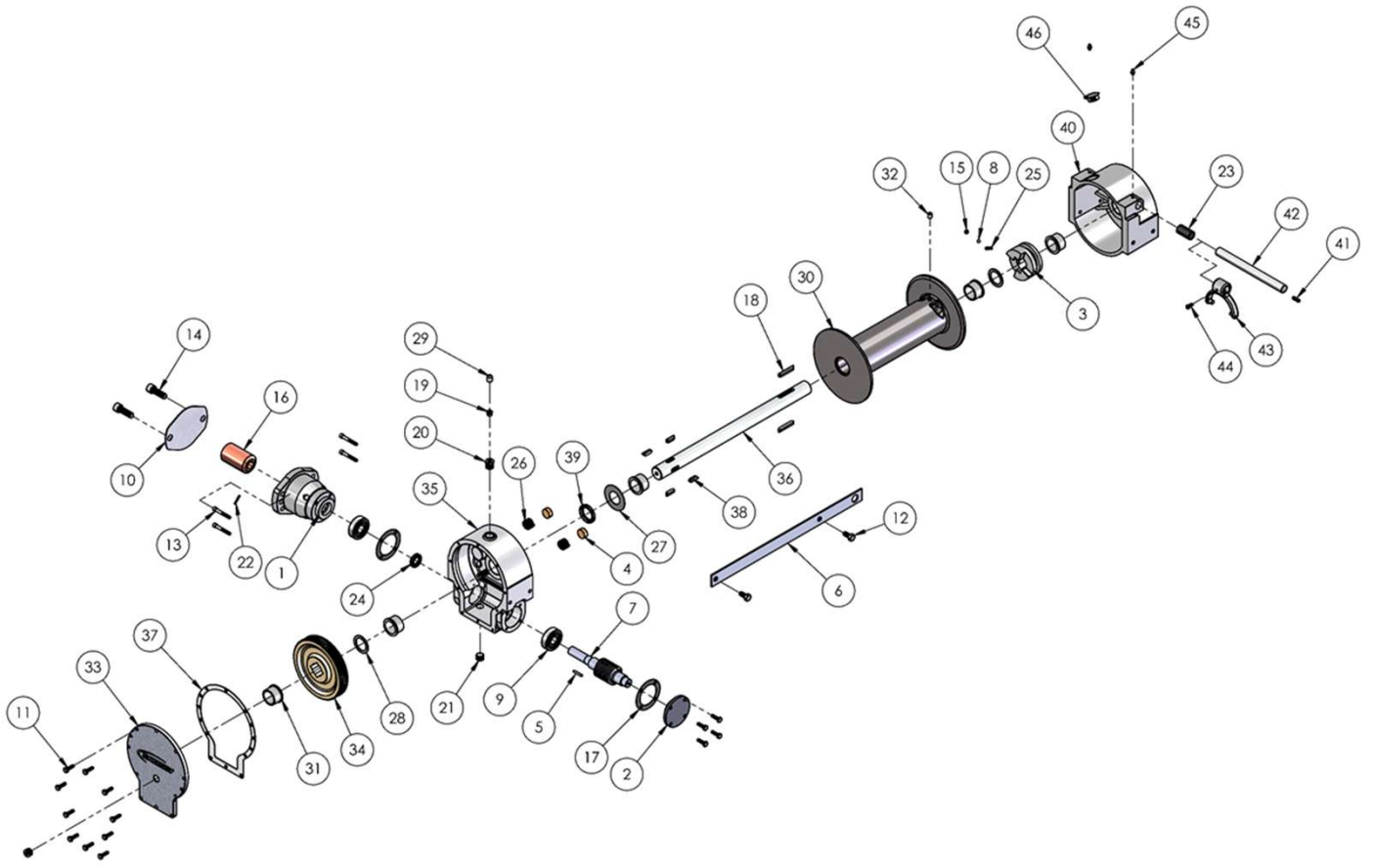

KITS AND MAINTENANCE PARTS

121787

Item#	QTY.	PART NUMBER	DESCRIPTION	KITS					
				207031	222054	246040	248055	250507	283081
1	1	300057	ADAPTER						
2	1	316083	CAP-BRG						
3	1	324161	JAW CLUTCH		X				
4	2	330010	SHOE-DRAG BRK,7/8DIA X3/8LG	X					
5	1	342027	KEY-RD ENDS,3/16X3/16X1LG						X
6	1	364145	STRAP-SHIP, 1/8X1 1/4X19LG,H200,J.D.						
7	1	368203	WORM-RH DL, HD 234						
8	1	400001	BALL-POPPET,1/4DIA		X				
9	2	402002	BEARING-BALL					X	
10	1	413013	COVER-HYD ADP						
11	14	414045	CAPSCREW-1/4-20NCX7/8 LG. HEX HD, GR 5						
12	2	414279	CAPSCREW-3/8-16NCX3/4 LG,HXHD,GR-5						
13	4	414842	CAPSCREW-1/4-20NCX1 3/4,HXSOC						
14	2	414952	CAPSCREW-1/2-13NCX1 1/2LG,SOCHD						
15	1	416040	SETSCREW-5/16-18NCX1/4LG HXSOCHD		X				
16	1	431008	COUPLING						X
17	2	442184	GASKET			X		X	
18	2	450006	KEY-BARTH,5/16X1 7/8LG						
19	1	456008	RELIEF FIT-1/8-27PFT						
20	1	468002	RED-3/8-1/8NPTF						
21	2	468018	PIPE PLUG-3/8-18NPTF HXSOCHD						
22	1	470033	SPIROL PIN-1/8X7/8						X
23	1	472006	CAP-PLAST		X				
24	1	486009	OIL SEAL-RL			X		X	
25	1	494001	SPRING		X				
26	2	494002	SPRING	X					
27	1	518014	THRUST WASHER-1/32				X		
28	2	518015	THRUST WASH				X		
29	1	530069	COVER-VENT PLUG						
30	1	332105	DRUM						
31	5	412045	BUSHING-GH				X		
32	1	416059	SETSCREW3/8-16NCX1/2 HX SOCK HD						
33	1	328134	COVER-GEAR HSG						
34	1	334183	WORM GEAR - RH					X	
35	1	338273	HOUSING-GEAR						
36	1	357479	SHAFT-DRUM					X	
37	1	442205	GASKET-GH			X		X	
38	4	450016	KEY-BARTH,5/16X 15/16L					X	

KITS AND MAINTENANCE PARTS

121787

				KITS					
Item#	QTY.	PART NUMBER	DESCRIPTION	207031	222054	246040	248055	250507	283081
39	1	486017	OIL SEAL			X		X	
40	1	338003	HOUSING-TENZALOY CASTING						
41	1	342024	KEY-SQ END 3/16X3/16X3/4LG		X				
42	1	356902	SHAFT-SHIFT		X				
43	1	370055	YOKE-CLUTCH		X				
44	1	416084	SETSCREW-1/4-20NCX1/2 SQHD		X				
45	2	456006	FITTING-LUBE, 1/4-28						
46	1	472013	PLUG-PLAST,1DIA						

KITS AND MAINTENANCE PARTS

121823

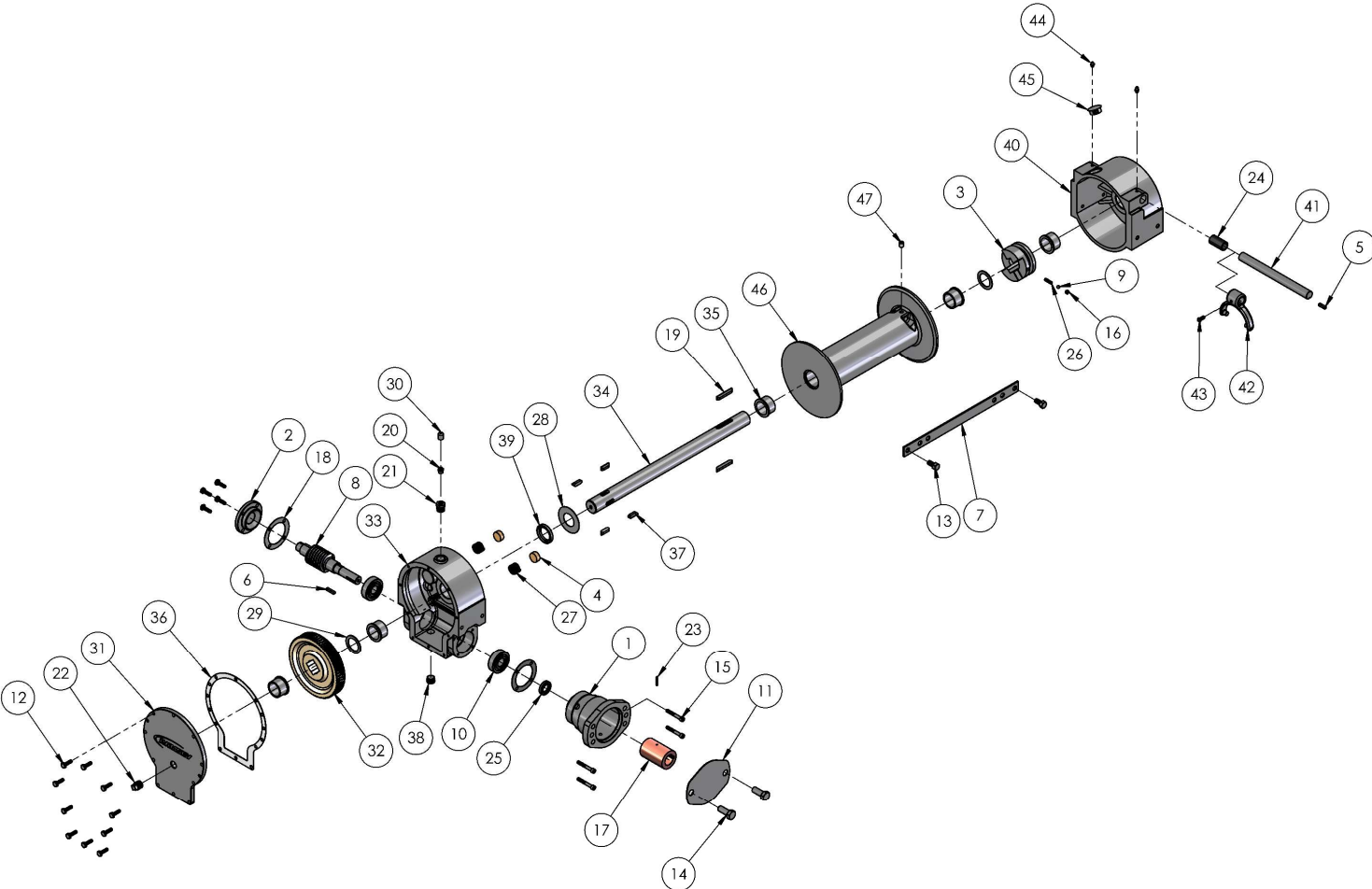

KITS AND MAINTENANCE PARTS

121823

Item#	QTY.	PART NUMBER	DESCRIPTION	KITS				
				207031	222054	246040	250507	283081
1	1	300057	ADAPTER					
2	1	316083	CAP-BRG					
3	1	324161	JAW CLUTCH		X			
4	2	330010	SHOE-DRAG BRK,7/8DIA X 3/8LG	X				
5	1	342024	KEY-SQ END 3/16X3/16X3/4LG		X			
6	1	342027	KEY-RD ENDS,3/16X3/16X1LG					X
7	1	364017	STRAP-SHIP,1/8 X 1 X 14 LG					
8	1	368203	WORM-RH DL					
9	1	400001	BALL-POPPET,1/4DIA		X			
10	2	402002	BEARING-BALL				X	
11	1	413013	COVER-HYD ADP					
12	14	414045	CAPSCREW-1/4-20NCX7/8 LG. HEX HD, GR 5					
13	2	414279	CAPSCREW-3/8-16NCX3/4 LG,HXHD,GR-5					
14	2	414521	CAPSCREW-1/2-13NCX1LG HXHD					
15	4	414842	CAPSCREW-1/4-20NCX1 3/4,HXSOC					
16	1	416040	SETSCREW-5/16-18NCX1/4LG HXSOCHD		X			
17	1	431008	COUPLING					X
18	2	442184	GASKET-BRG CAP			X	X	
19	2	450006	KEY-BARTH,5/16X1 7/8LG					
20	1	456008	RELIEF FIT-1/8-27PFT					
21	1	468002	RED-3/8-1/8NPTF					
22	1	468011	PIPE PLUG-3/8-18NPTF,7/16 SQ HD					
23	1	470033	SPIROL PIN-1/8X7/8					X
24	1	472006	CAP-PLAST/WM		X			
25	1	486009	OIL SEAL			X	X	
26	1	494001	SPRING		X			
27	2	494002	SPRING	X				
28	1	518014	THRUST WASHER-1/32					
29	2	518015	THRUST WASH					
30	1	530069	COVER-VENT PLUG					
31	1	328134	COVER-GEAR HSG					
32	1	334183	WORM GEAR				X	
33	1	338273	HOUSING-GEAR					
34	1	357479	SHAFT-DRUM				X	
35	5	412045	BUSHING-GH					
36	1	442205	GASKET-GH CVR			X	X	
37	4	450016	KEY-BARTH,5/16X 15/16L				X	

KITS AND MAINTENANCE PARTS

121823

				KITS				
Item#	QTY.	PART NUMBER	DESCRIPTION	207031	222054	246040	250507	283081
38	1	468018	PIPE PLUG-3/8-18NPTF HXSOCHD					
39	1	486017	OIL SEAL			X	X	
40	1	338003	HOUSING-TENZALOY CASTING					
41	1	356902	SHAFT-SHIFT		X			
42	1	370055	YOKE-CLUTCH		X			
43	1	416084	SETSCREW-1/4-20NCX1/2 SQHD		X			
44	2	456006	FITTING-LUBE, 1/4-28 TAPER					
45	1	472013	PLUG-PLAST,1DIA					
46	1	332105	DRUM					
47	1	416059	SETSCREW3/8-16NCX1/2 HX SOCK HD CUP					

**RAMSEY WINCH INDUSTRIAL WINCH
LIMITED WARRANTY**

1.1 Scope of Warranty Coverage. Upon the terms and subject to the conditions set forth in this limited warranty:

- (a) RAMSEY WINCH (referred to herein as “**RAMSEY WINCH**” or the “**Manufacturer**”) warrants to each initial end user customer (a “**Purchaser**”) of a new industrial winch together with any accessories manufactured and sold directly from RAMSEY WINCH (the “**Product**”) that the Product shall be free from defects in material and workmanship, under normal working and service conditions, for a period of eighteen (18) months from the date the Product is shipped from RAMSEY WINCH. (the “**Warranty Term**”). A Purchaser shall be eligible for an additional eighteen (18) months of coverage in addition to the Warranty Term (also referred to as the “**Standard (+) PLUS benefit**”) only if the Purchaser (i) complies with Section 1.2(a) and (ii) registers the Product during the Warranty Term at myproduct.ramseywinch.com.
- (b) Notwithstanding the foregoing, this warranty does not cover components damaged by accident, abuse, misuse, neglect, untrained operators, collision, overloading, modification, disassembly, rework, misapplication, improper installation, lack of lubrication or maintenance, or improper service. This warranty does not cover the paint or material finish, rope (wire or synthetic), removal or reinstallation of the winch, or normal wear and tear and loss of functionality due to aging of the Product (which may include but is not limited to bearings, bushings, seals, O-rings, gaskets, brake material, motor brushes, electrical cables and more).

1.2 Eligibility of Warranty Coverage.

- (a) A Purchaser shall be eligible for warranty coverage under this Limited Warranty during the Warranty Term only if:
 - (i) Prior to placing a Product in service, and throughout use of the Product during the Warranty Term, the Purchaser provides (or causes to be provided) proper storage such that foreign objects (e.g. rain or debris) cannot enter any Product through entry ports which are normally closed during operation.; and
 - (ii) The Purchaser maintains, or causes to be maintained, the Product according to commercially reasonable standards and utilizes the Product for the purposes for which it was created; and
 - (iii) No repairs or alterations have been made by any party other than RAMSEY WINCH, including Purchaser, unless otherwise authorized in writing by RAMSEY WINCH.

1.3 Transferability of Warranty.

- (a) This warranty is transferable only from the Purchaser to the first subsequent transferee (the “**Transferee**”) of the Product from Purchaser upon (i) written notification to RAMSEY WINCH and (ii) registration of the transfer, both within 30 days of such Product transfer.
- (b) Upon satisfaction of transfer requirements set forth in Section 1.3(a), the Transferee shall succeed to all the rights and obligations of the Purchaser set forth in this Limited Warranty.

1.4 Certain Limitations on Scope of Warranty Service.

- (a) Any obligation of RAMSEY WINCH under this warranty, statutory or otherwise, is limited to the repair of the Product, at its factory or Authorized Service Centers. Notwithstanding the foregoing, if field service or repair is performed by RAMSEY WINCH at the request of the Purchaser and no defect is found with material or workmanship of the Product, the Purchaser shall compensate RAMSEY WINCH for its time and expenses within thirty (30) days of delivery of an invoice relating to the same. If repair is determined by RAMSEY WINCH in its sole, absolute and uncontrolled discretion to be impossible or impractical, then RAMSEY WINCH may satisfy this warranty by replacing the Product. RAMSEY WINCH will not provide any cash payment or credits for defective materials or workmanship.

- (b) Purchaser shall be responsible for any and all freight charges for any Product receiving warranty service under this limited warranty. Any travel time, transportation charges, freight charges, or similar costs incurred by RAMSEY WINCH in connection with the replacement or repair of defective parts, shall, be the responsibility of the Purchaser. If applicable, RAMSEY WINCH shall invoice Purchaser for the total amount of such charges within sixty (60) days of fulfilling its duties under this warranty, payable within thirty (30) days of delivery of such invoice. In no event shall RAMSEY WINCH be liable for bills for service, labor or other expenses that have been incurred by the Purchaser without approval or prior authorization by RAMSEY WINCH for inspection, maintenance, or repair of the Product.
- (c) If a Product is found to be operable upon inspection, the Product, at Purchaser's election, may be either (1) returned to the Purchaser with a service charge from RAMSEY WINCH for inspection, cleaning, and routine replacement of all rubber components and any other parts that show wear; or (2) RAMSEY WINCH can dispose of the product safely.

1.5 **Limitations of Liability.** RAMSEY WINCH shall in no event be liable for punitive, special or consequential damages relating to the Product or this Warranty. RAMSEY WINCH makes no warranty in respect to third-party accessories, upgrades, or additions to the Product.

1.6 **Improving Product.** RAMSEY WINCH reserves the right to improve the Product through changes in design or materials as it may deem desirable or necessary without being obligated to incorporate, upgrade, or otherwise modify previously manufactured products.

1.7 **Limitations of Warranty.**

- (a) THE WARRANTY SET FORTH ABOVE IS THE ONLY EXPRESS WARRANTY. RAMSEY WINCH HEREBY DISCLAIMS AND EXCLUDES ANY OTHER EXPRESS, IMPLIED, OR STATUTORY WARRANTIES, ARISING BY OPERATION OF LAW, COURSE OF DEALING, COURSE OF PERFORMANCE, USAGE, OF TRADE, OR OTHERWISE, INCLUDING, WITHOUT LIMITATION, ANY WARRANTIES OF MERCHANTABILITY, FITNESS FOR A PARTICULAR PURPOSE, AND INTELLECTUAL PROPERTY RIGHTS OF A THIRD PARTY.
- (b) ANY IMPLIED WARRANTY WHICH BY LAW MAY NOT BE EXCLUDED IS LIMITED IN DURATION TO ONE (1) YEAR FROM THE DATE OF ORIGINAL RETAIL PURCHASE OF THE PRODUCT.
- (c) This warranty gives you specific legal rights, and you may also have other rights which vary from jurisdiction to jurisdiction.
- (d) This warranty is valid only in the U.S.A. and Canada. For warranty outside the U.S.A. and Canada contact your nearest Ramsey Winch Distributor.

1.8 **No Modifications to Warranty.** No RAMSEY WINCH dealer, distributor, agent or employee is authorized to make any modification, extension or addition to this warranty.

1.9 **How to Apply for Warranty Coverage.**

All claims are handled by contacting your nearest Ramsey Winch Distributor. For questions, please contact customer support: rwcustomersupport@ramseyindustries.com.

Visit [Dealer Locator - Ramsey Winch](#) for Ramsey Winch Distributor locations and contact information.

Additional warranty, service support, product information, and parts information can be found on www.ramseywinch.com.

