

OM-914001-0226-G

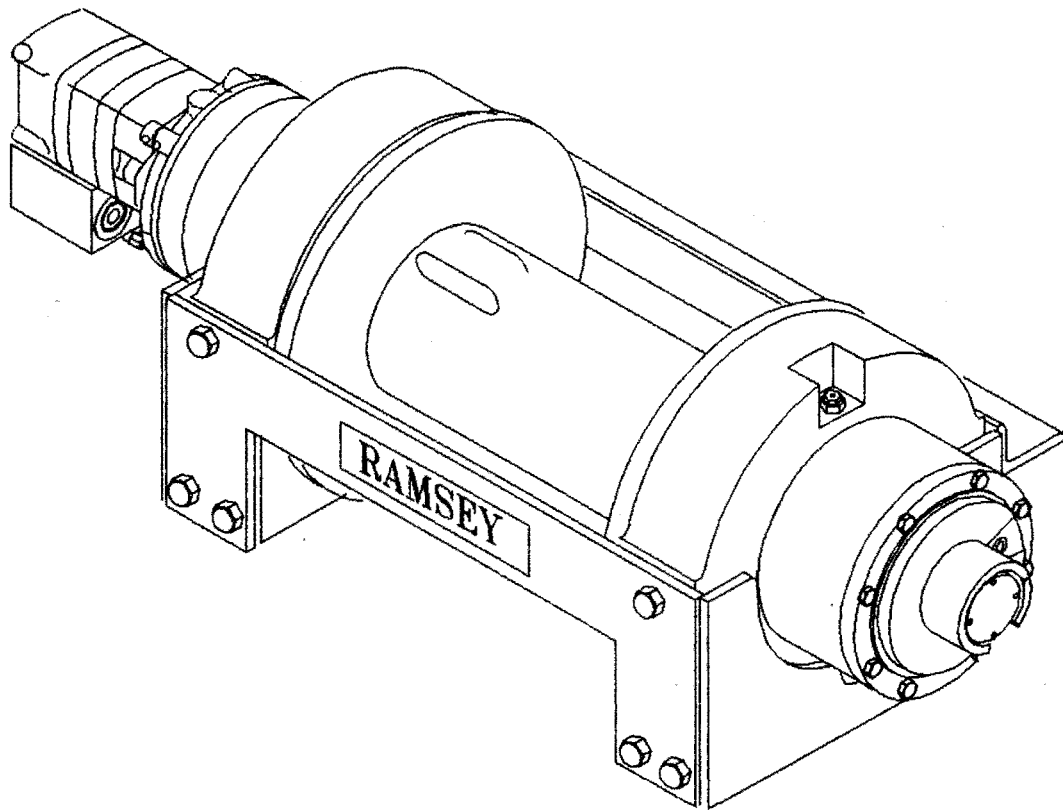

# OPERATING, SERVICE AND MAINTENANCE MANUAL



## MODEL RPH-25,000 INDUSTRIAL PLANETARY WINCH



**CAUTION:** READ AND UNDERSTAND THIS MANUAL BEFORE INSTALLATION AND OPERATION OF WINCH. SEE WARNINGS!

## TABLE OF CONTENTS

INTRODUCTION.....	1
WARRANTY INFORMATION.....	1
SPECIFICATIONS.....	1
WARNINGS.....	1
WINCH FRAME MOUNTING.....	2
CABLE INSTALLATION.....	2
HYDRAULIC SYSTEM REQUIREMENTS.....	2
PERFORMANCE CHARTS.....	3
CLUTCH OPERATION.....	3
WINCH OPERATION.....	3
MAINTENANCE.....	4
TROUBLE SHOOTING GUIDE.....	4
INSTRUCTIONS FOR OVERHAUL.....	5-12
MOUNTING CONFIGURATIONS.....	12
DIMENSIONAL DRAWING.....	13
PARTS LIST AND PART DRAWING.....	14-15
LIMITED WARRANTY.....	BACK COVER

# **RAMSEY HYDRAULIC PLANETARY WINCH MODEL RPH 25,000**

## **PLEASE READ THIS MANUAL CAREFULLY**

This manual contains useful ideas in obtaining the most efficient operation from your Ramsey Winch, and safety procedures one needs to know before operating a Ramsey Winch. Do not operate this winch until you have carefully read and understand the "WARNINGS" and "OPERATION" sections of this manual.

## **WARRANTY INFORMATION**

Ramsey Winches are designed and built to exacting specifications. Great care and skill go into every winch we make. If the need should arise, warranty procedure is outlined on the back of your self-addressed postage paid warranty card. Please read and fill out the enclosed warranty card and send it to Ramsey Winch Company. If you have any problems with our winch, please follow instructions for prompt service on all warranty claims. Refer to back page for limited warranty.

## **SPECIFICATIONS\***

Rated Line Pull (lbs.).....		25,000				
(Kgs.).....		11,340				
Gear Reduction.....		25.53:1				
Weight (without cable).....		380 lb. (172,0 Kgs.)				
LAYER OF CABLE		1	2	3	4	5 **
*Rated line pull per layer	Lbs.	25,000	20,800	17,900	15,600	13,900
	Kg.	11,340	9,430	8,110	7,070	6,300
*Cable capacity	Ft.	35	75	125	185	245
	M.	10	22	38	56	74
*Line speed (at 15 GPM)	FPM	27	31	36	41	46
	MPM	8,3	9,5	11,1	11,8	14,0
* These specifications are based on recommended wire rope of .62" dia. Extra Improved Plow Steel or equivalent.						
** Does not comply with SAE J706						

**NOTE:** The rated line pulls shown are for the winch only. Consult the wire rope manufacturer for wire rope ratings.

## **WARNINGS:**

**CLUTCH MUST BE TOTALLY ENGAGED BEFORE STARTING THE WINCHING OPERATION.**

**DO NOT START WINCH MOTOR BEFORE ENGAGING CLUTCH**

**DO NOT DISENGAGE CLUTCH UNDER LOAD.**

**STAY OUT FROM UNDER AND AWAY FROM RAISED LOADS.**

**STAND CLEAR OF CABLE WHILE PULLING. DO NOT TRY TO GUIDE CABLE.**

**DO NOT EXCEED MAXIMUM LINE PULL RATINGS SHOWN IN TABLE.**

**DO NOT USE WINCH TO LIFT, SUPPORT, OR OTHERWISE TRANSPORT PEOPLE.**

**A MINIMUM OF 5 WRAPS OF CABLE AROUND THE DRUM BARREL IS NECESSARY TO HOLD THE LOAD.**

**CABLE ANCHOR IS NOT DESIGNED TO HOLD LOAD.**

## WINCH FRAME MOUNTING

Use (8) 1/2 inch diameter grade 8 or better bolts to attach lower mounting frame to wrecker.

## CABLE INSTALLATION

The RPH-25000 winch has two tapered pockets cast into the drum. One pocket is for installations with the wire rope wound over the drum. The other pocket is for an underwound wire rope. When properly used, the wedge pocket design is one of the most secure anchoring methods available.

1. Unwind cable by rolling it out along the ground to prevent kinking. Securely wrap end of wire rope, opposite hook, with plastic or similar tape to prevent fraying.
2. Slide the wire rope through narrow end of the pocket against the drum flange and wrap the wire rope around the anchor "puck" and pull the wire rope and anchor back into the wide end of the pocket. Use a soft hammer to drive the back side of the wire rope, firmly seating the wire rope and anchor, into the pocket.
3. Carefully run winch in the "reel-in" direction. Keeping tension on end of cable, spool all the cable onto the cable drum, taking care to form neatly wrapped layers.

The wire rope can easily be removed from the drum by driving the anchor out the wide end of the pocket.

## HYDRAULIC SYSTEM REQUIREMENTS

Refer to the performance charts, below, to properly match your hydraulic system to RPH-25000 winch performance. The charts consist of :

(1) Line pull (lb.) first layer vs. working pressure (PSI) and (2) Line speed, first layer (FPM) vs. gallons per minute (GPM). Performance based on a motor displacement of 8.0 cubic inches with 15 GPM maximum flow rate. See page 13 for motor port size.

## TYPICAL LAYOUT

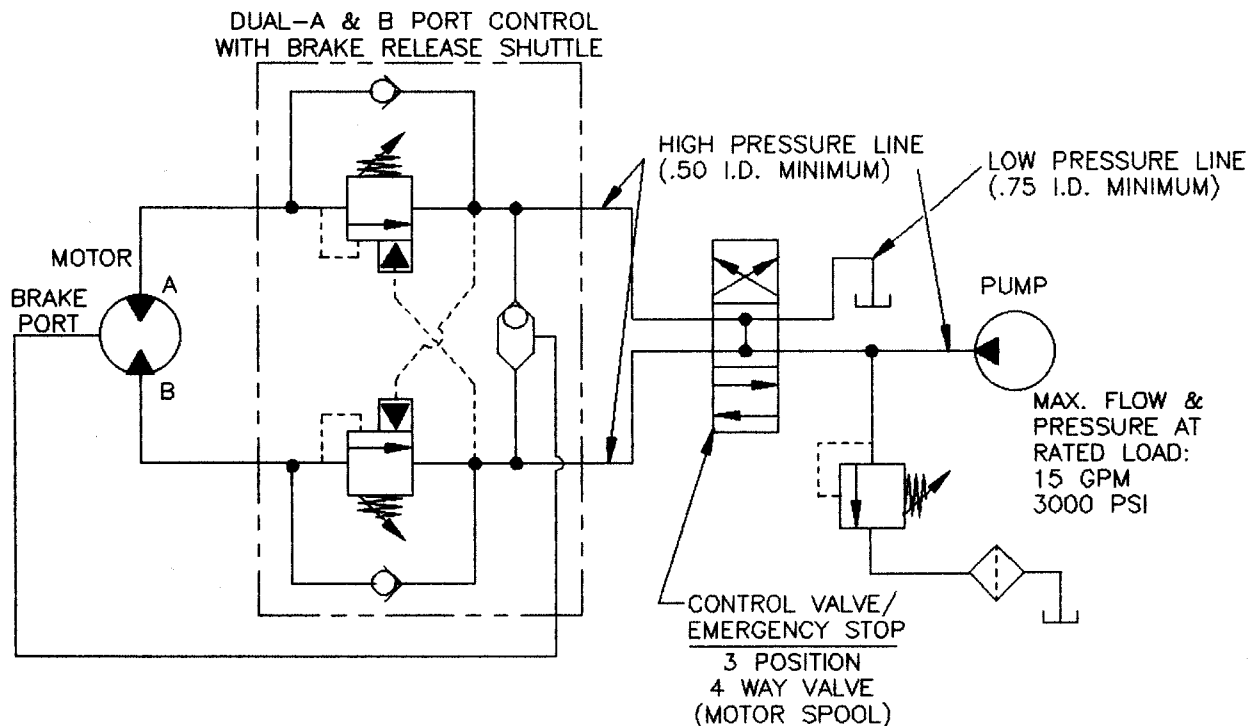

## PERFORMANCE CHARTS

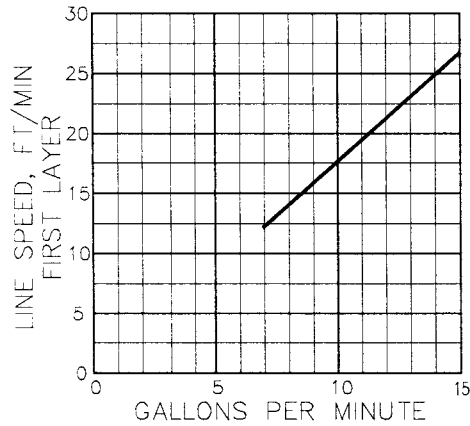
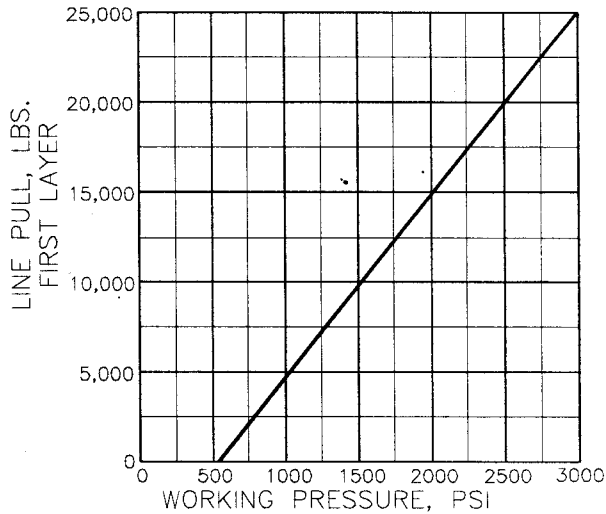

BASED ON 8.0 CU. IN./REV. MOTOR

## CLUTCH OPERATION

### To engage clutch:

1. Move the clutch control valve to the "clutch-engaged" position.
2. Anytime the temperature is below freezing, run motor in the "cable out" direction only until the drum starts to turn.
  - 2a. In extreme cold temperatures (below 0° F/-18° C), pull out on the cable by hand only until the drum starts to turn.
3. Wait at least 3 seconds for the clutch to fully engage, after which the winch is ready to winch in the cable.

**WARNING:** Do not attempt to engage the clutch by first running the winch motor and then moving the clutch control valve to the "clutch-engaged" position while the motor is running. Do not start picking up the load at the same time the clutch is being engaged.

### To disengage clutch:

1. Run the winch in the "cable out" direction until the load is off the cable.
2. Move the clutch control valve to the "clutch-disengaged" position.
3. The cable may now be pulled off by hand

## WINCH OPERATION

The best way to get acquainted with how your winch operates is to make test runs before you actually use it. Plan your test in advance. Remember, you hear your winch, as well as see it operate. Get to recognize the sounds of a light steady pull, a heavy pull, and sounds caused by load jerking or shifting. Gain confidence in operating your winch and its use will become second nature with you.

The uneven spooling of cable, while pulling a load, is not a problem, unless there is a cable pileup on one end of drum. If this happens reverse the winch to relieve the load and move your anchor point further to the center of the vehicle. After the job is done you can unspool and rewind for a neat lay of the cable.

## **MAINTENANCE**

Adhering to the following maintenance schedule will keep your winch in top condition and performing as it should with a minimum of repair.

### **A. WEEKLY**

1. Check the oil level and maintain it to the oil level plug. If oil is leaking out, determine location and repair.
2. Check the pressure relief plug in top of the gear housing. Be sure that it is not plugged. Lubricate cable with light oil.

### **B. MONTHLY**

1. Check the winch mounting bolts. If any are missing, replace them and securely tighten any that are loose. Use grade 5 or better bolts.
2. Inspect the cable. If the cable has become frayed with broken strands, replace immediately.

### **C. ANNUALLY**

1. Drain the oil from the winch annually or more often if winch is used frequently.
2. Fill the winch to the oil level plug with clean kerosene. Run the winch a few seconds with no load in the reel in direction. Drain the kerosene from the winch.
3. Refill the winch to the oil level plug with all purpose SAE 80W-140 gear oil.
4. Inspect frame and surrounding structure for cracks or deformation.

## **TROUBLE SHOOTING GUIDE**

<b>CONDITIONS</b>	<b>POSSIBLE CAUSE</b>	<b>CORRECTION</b>
<b>OIL LEAKS FROM WINCH</b>	<ol style="list-style-type: none"><li>1. Seals damaged or worn.</li><li>2. Too much oil.</li><li>3. Damaged gaskets.</li></ol>	<ol style="list-style-type: none"><li>1. Replace seal.</li><li>2. Drain excess oil. Refer to OPERATION.</li><li>3. Replace gaskets.</li></ol>
<b>WINCH RUNS TOO SLOW HYDRAULIC</b>	<ol style="list-style-type: none"><li>1. Low flow rate</li><li>2. Hydraulic motor worn out.</li></ol>	<ol style="list-style-type: none"><li>1. Check flow rate. Refer to SYSTEMS flow chart page 3.</li><li>2. Replace motor.</li></ol>
<b>CABLE DRUM WILL NOT FREESPOOL</b>	<ol style="list-style-type: none"><li>1. Clutch not disengaged</li></ol>	<ol style="list-style-type: none"><li>1. Check air pressure to clutch cylinder 90 PSI minimum required-Refer to page 13.</li></ol>
<b>BRAKE WILL NOT RELEASE</b>	<ol style="list-style-type: none"><li>1. Air in hydraulic system</li></ol>	<ol style="list-style-type: none"><li>1. Bleed air from brake. Refer to page 12.</li></ol>

## INSTRUCTIONS FOR OVERHAUL

1. Drain oil from gear housing (item #10) by removing pipe cap (item #46) from pipe nipple in end bearing. Remove reducer and relief fitting (items #44 & #38).

If new air cylinder is required, remove air cylinder (item #33) from adapter (item #4) by removing (4) capscrews (item #26). Remove breather vent (item #39). Remove washer (item #28), nut and setscrew (items #29 & #25) and insert (item #31) from end of air cylinder rod. Apply Loc-tite to threads of nut (item #29) and thread onto setscrew (item #25) to 3/8 inch from drive end, as shown below. Apply Loc-tite to threads of setscrew and thread insert (item #31) over end of setscrew and against nut. Use setscrew and nut to thread insert (item #31) into end of air cylinder rod. Tighten nut against cylinder rod, keeping 3/8 inch distance from drive end of setscrew to nut. Be sure breather vent (item #39) and relief fitting (item #38) are not damaged and in good operating condition. Replace if necessary.

Remove air cylinder adapter (item #4) and gasket (item #37) from gear housing cover by unscrewing (4) capscrews (item #21).

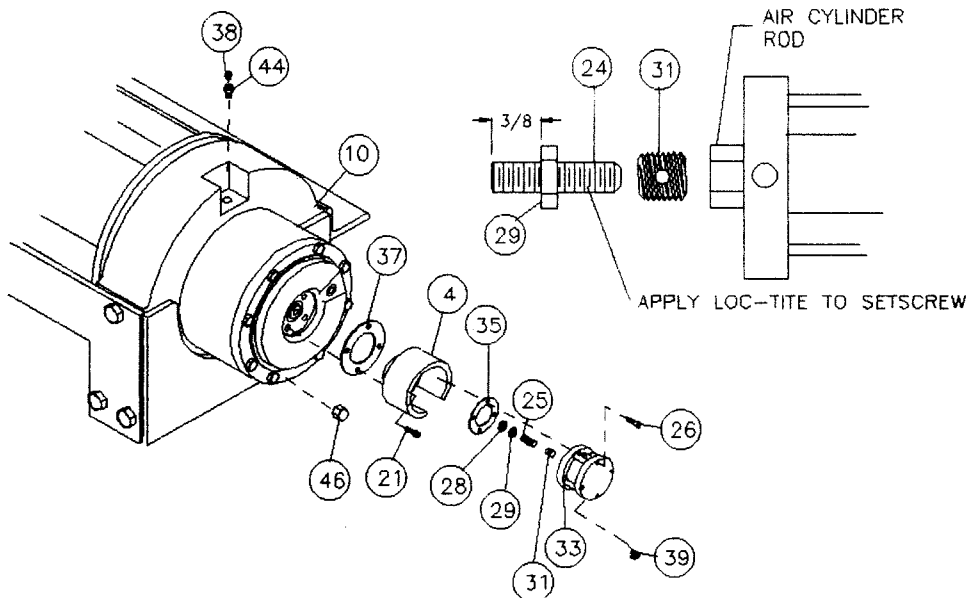

2. Disconnect tube (item #49) from elbows (item #32), as shown. Remove motor (item #40) and gasket (item #36) by removing (2) capscrews (item #23). Remove valve (item #50), if needed, from motor by removing (3) capscrews (item #22), as shown on page 14.

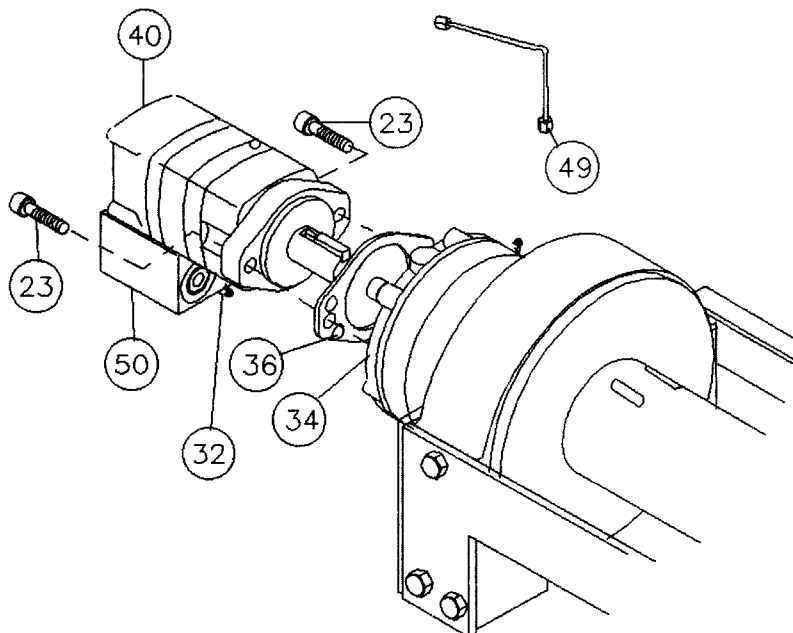

3. Remove brake assembly (item #34) by removing (2) mounting screws (item #24) attaching brake to end bearing (item #9). CAUTION: Brake is spring loaded by clutch spring and must be restrained against end bearing as mounting screws (item #24) are removed. Remove coupling (item #7) and gasket (item #51) from end bearing. Take note of mounting configuration for proper mounting of parts during re-assembly.

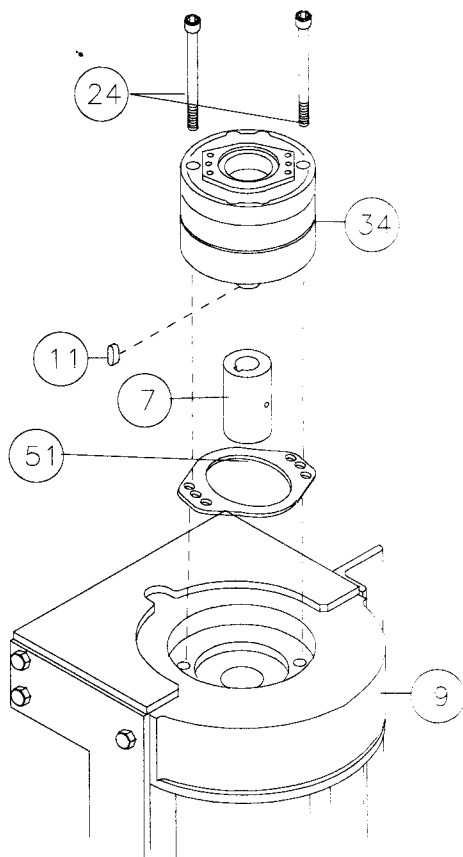

4. Remove winch from upright mounting frame (item #2) by removing (10) capscrews (item #20), (10) lockwashers (item #27) and (2) capscrews (item #19) with (2) lockwashers (item #27). Pull motor end bearing (item #9) from drum assembly (item #1).

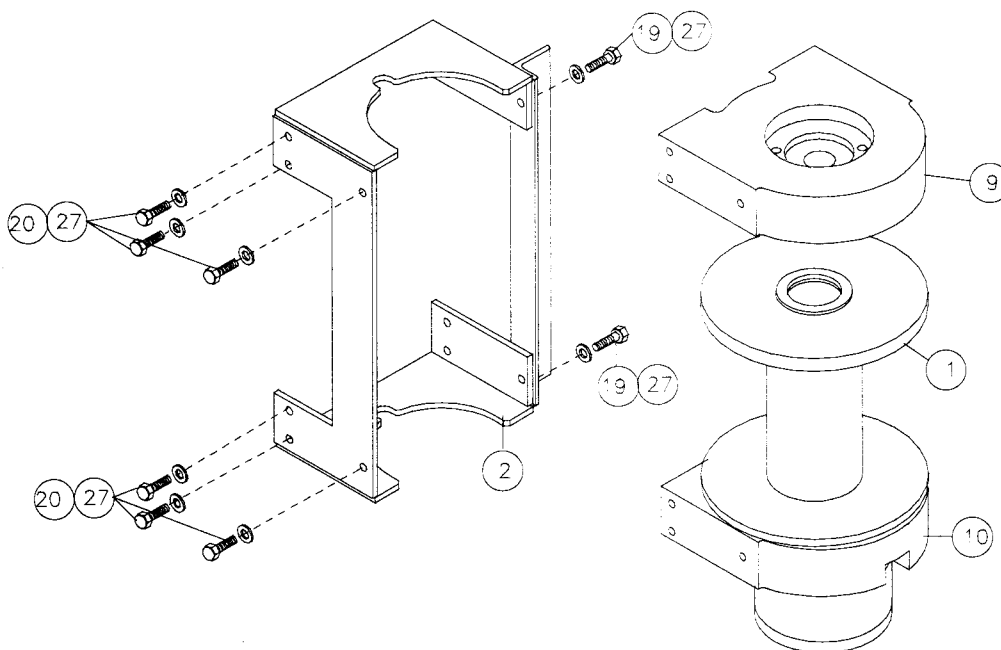

5. Pull drum assembly (item #1) upward from end bearing (item #10). Remove quad-rings (item #41 & #42) from grooves in drum bushings. Remove input shaft (item #12), clutch spring (item #48) and washer (item #30) from end bearing (item #10). Examine key (item #11) and input shaft for signs of wear, replace if damaged.

Examine drum assembly (item #1) for signs of wear. If splines inside of drum driver (332166) are damaged, drum driver must be replaced. Remove drum driver by unscrewing (8) capscrews (414962). Place well-oiled o-ring (462053) into drum driver groove and attach driver to drum (332165) using (8) capscrews (414962). Torque capscrews to 55 ft. lbs. each, in criss-cross pattern.

Press old bushings from drum and drum driver. Remove o-rings (462055 & 462052) from grooves in drum and drum driver bushing (412092). Place well-oiled o-rings (462055 & 462052) into grooves in drum and outer diameter of drum driver bushing (412092). Press new bushing (412091) into end of drum opposite drum driver and press bushing (412092) into drum driver until flange of bushings are flush against drum and driver. Secure bushings to drum and drum driver using (2) capscrews (414819).

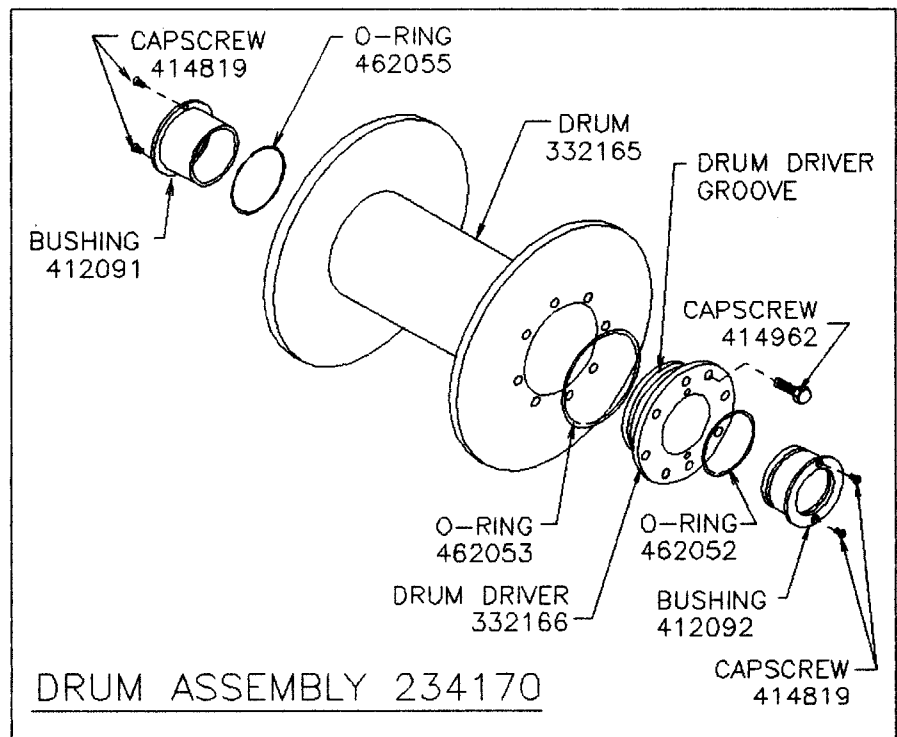
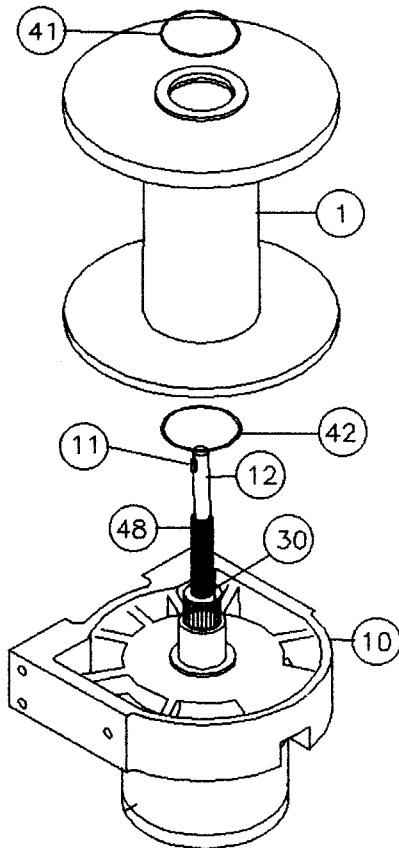

6. Remove output coupling (item #8) and coupling shaft (item #6) from end bearing (item #10). Examine bearings (item #15), pressed in output coupling (item #8), for signs of wear. Replace bearings, if necessary, by pressing old bearings from coupling and press new bearings (item #15) into each end of output coupling (item #8). Place coupling shaft (item #6) into bearings (item #15).

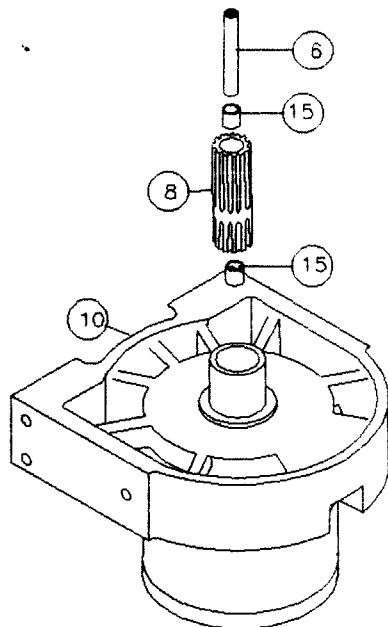

7. Remove (8) capscrews (item #17) to pull gear housing cover from ring gear. Remove input thrust washer, sun gear and carrier assemblies and spacer (item #14) from inside of ring gear. Examine splines of ring gear and if necessary, remove ring gear from end bearing (item #10) by removing (9) capscrews (item #18). Examine bushing (item #16) for signs of wear. Replace bushing, if necessary, by pressing old bushing from housing and pressing new bushing into place.

Apply RTV sealing compound to ring gear mounting surface of end bearing (item #10). Place ring gear onto end bearing, aligning holes in ring gear with holes and gear housing end bearing. Secure ring gear to end bearing using (9) capscrews (item #18). Examine shifter shaft (item #13) for signs of wear, replace if necessary.

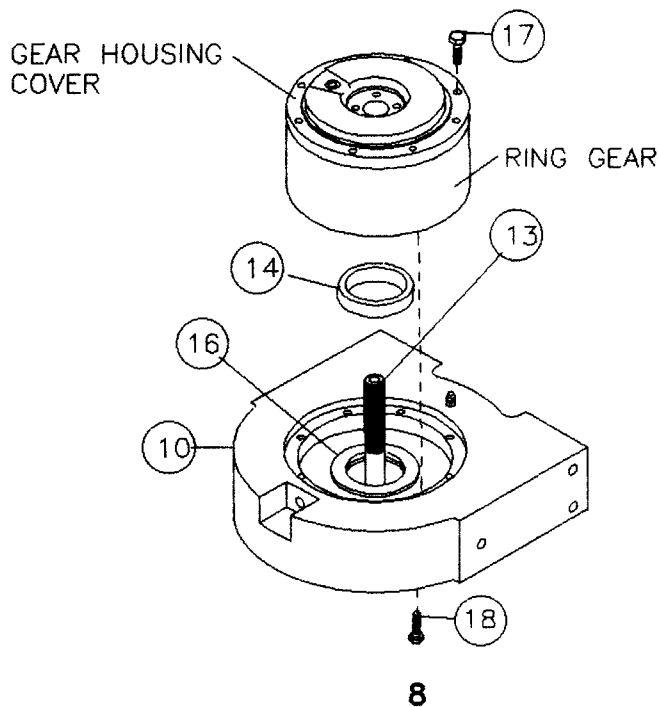

8. NOTE: DETERMINE MOUNTING CONFIGURATION OF WINCH (R.H. or L.H. MOUNTED) BEFORE ATTACHING UPRIGHT FRAME TO WINCH, TO ASSURE PARTS ARE MOUNTED TO PROPER SIDE, REFER TO WINCH MOUNTING CONFIGURATIONS, STEP 14 PAGE 12.

Seat well-oiled quad-rings (item #41 & #42) into groove of bushing in each end of drum assembly (item #1), as shown. Carefully set drum assembly (item #1) down over motor end bearing (item #9). Lift gear housing end bearing (item #10) and set into place on drum assembly. Attach upright frame (item #2) to end bearings. Install (4) upper-most capscrews (items #20 & #19) with lockwashers (item #27) and hand tighten. Install (8) lower-most capscrews with lockwashers (item #20 & #27). Tighten (4) upper-most capscrews securely, check rotation of cable drum. Tighten (8) lower-most capscrews securely, check rotation of cable drum. Torque the upper-most (item #19) to capscrews to 85 ft.lbs. each, then lower-most (item #20) capscrew to 102 ft.lbs. each. Make sure cable drum assembly rotates freely at this point.

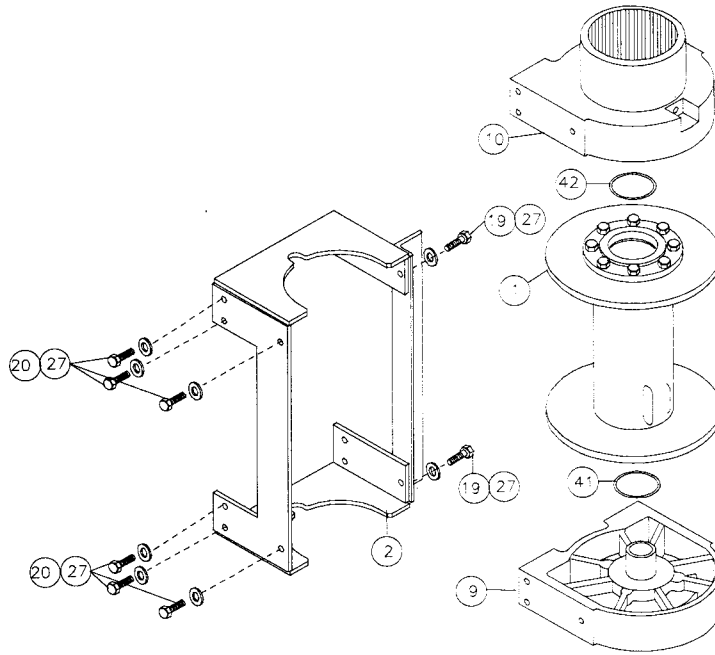

9. Gently tap key (item #11) into keyway of input shaft (item #12). Liberally apply grease to shoulder of input shaft (item #12). Place spring (item #48) over splined end of shaft. Use grease to hold spring in place on shaft.

Place spring and splined end of shaft through motor end bearing (item #9) and drum until shaft extends through bushing (item #16) in end bearing (item #10). Place clutch washer (item #30) over splined end of shaft and against spring. Place end of output coupling assembly (item #8), with longest splines, through end bearing bushing (item #16) and mesh shaft coupling spline with splined end of shaft. Place short splined end of shifter shaft (item #13) through washer (item #30) and into shaft coupling (item #6), meshing splines of shifter shaft with splines in shaft coupling.

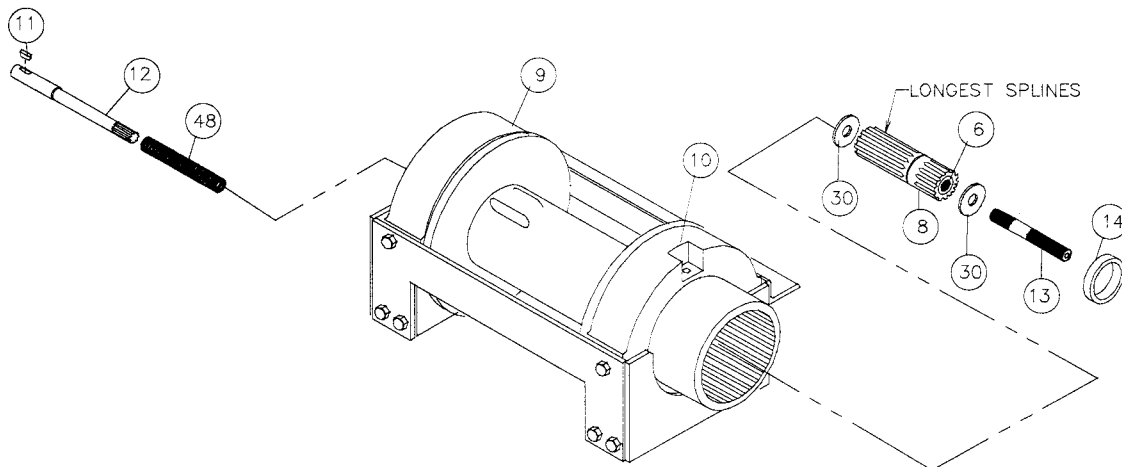

10. Place (2) gear carrier assemblies into ring gear meshing carrier gears with ring gear. Make sure that ring gear and carrier assemblies are securely against end bearing (item #10). Apply RTV sealing compound to cover mounting surface of ring gear and attach cover to ring gear. Use (8) capscrews (item #17) to secure gear box cover to gear housing end bearing. Torque capscrews to 28 ft. lbs. each, in criss-cross pattern.

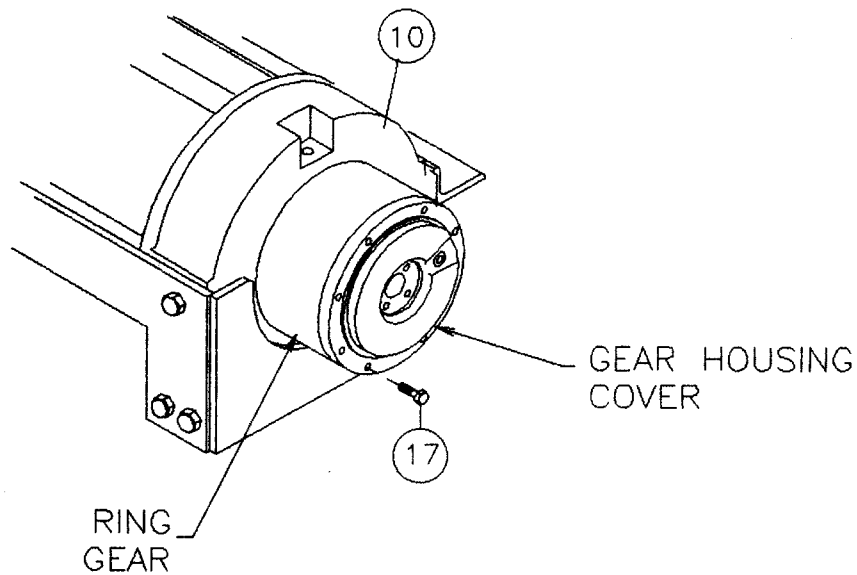

11. Place gasket (item #37) into position on gear box cover with sealer and attach adapter to cover using (4) capscrews (item #21). Apply Loctite PST thread sealer to threads of capscrews. Torque capscrews to 13 ft. lbs. each, in criss-cross pattern.

Pull rod from air cylinder as far as possible. Slide washer (item #29) over setscrew (item #25) and against nut attached to air cylinder rod. Place setscrew into hole of shifter shaft (item #13). Attach new air cylinder (item #33) and gasket (item #35) with sealer, to adapter using (4) capscrews (item #26). Apply Loctite PST thread sealer to threads of capscrews. Torque capscrews to 5 ft. lbs. each, in criss-cross pattern.

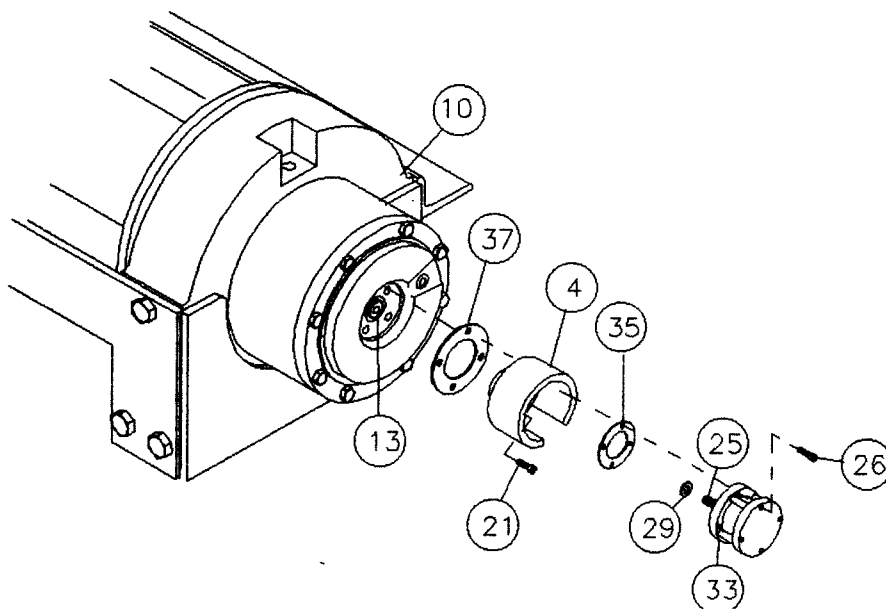

12. With pin (item #46) installed in coupling, align keyway of coupling (item #7) with key and end of input shaft below. Slide coupling over end of shaft (item #12). Place gasket (Item #51) into position on motor mounting surface of end bearing (item #9). Insert brake shaft (with key) into coupling. Use (2) screws (item #24) to attach brake assembly to motor end bearing.

Alternately tighten one, then the other of the capscrews (item #24) in a back and forth manner, thus compressing spring (item #48) and pulling the brake assembly down against end bearing (item #9). Torque capscrews to 85 ft lbs each.

NOTE: Care must be taken to assure brake assembly is seated properly prior to installing 1/2-13UNC assembly bolts. Damage will occur to rotor stack or shaft snap ring if not properly seated.

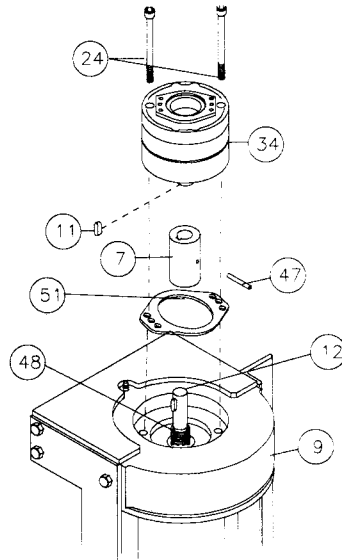

13. Attach motor (item #40) with gasket (item #36) to brake (item #34). Use (2) capscrews (item #23) and torque to 74 ft. lbs. each. Securely connect tube (item #49) to elbow (item #32), in bottom of valve (item #50), and brake (item #34).

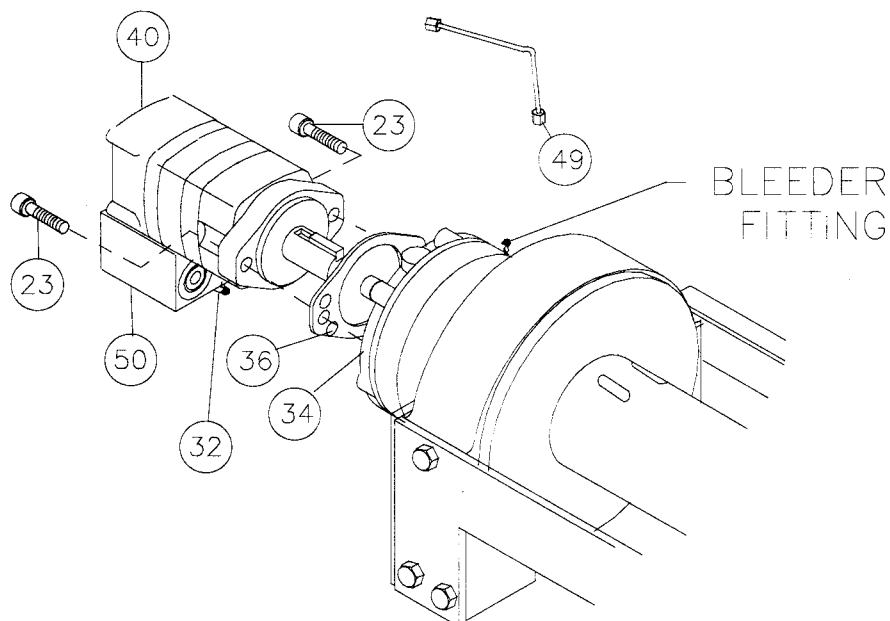

14. Apply Permatex to threads of pipe cap (item #46). Thread pipe cap onto pipe nipple in bottom of gear housing end bearing (item #10). Pour approx. 1.75 pints of SAE 80W-140 oil into end bearing. Check oil level by removing oil plug noted below. Insert relief fitting (item #38) and thread reducer (item #44) into end bearing at oil fill hole.

Install winch and connect pressure lines. Bleed pressure release section of brake by loosening bleeder fitting on brake and allowing air to escape while slowly applying hydraulic system pressure to the winch (refer to bleeder fitting in step 13). Apply at least 230 PSI pressure to release brake and verify that brake releases, by observing that the winch drum rotates.

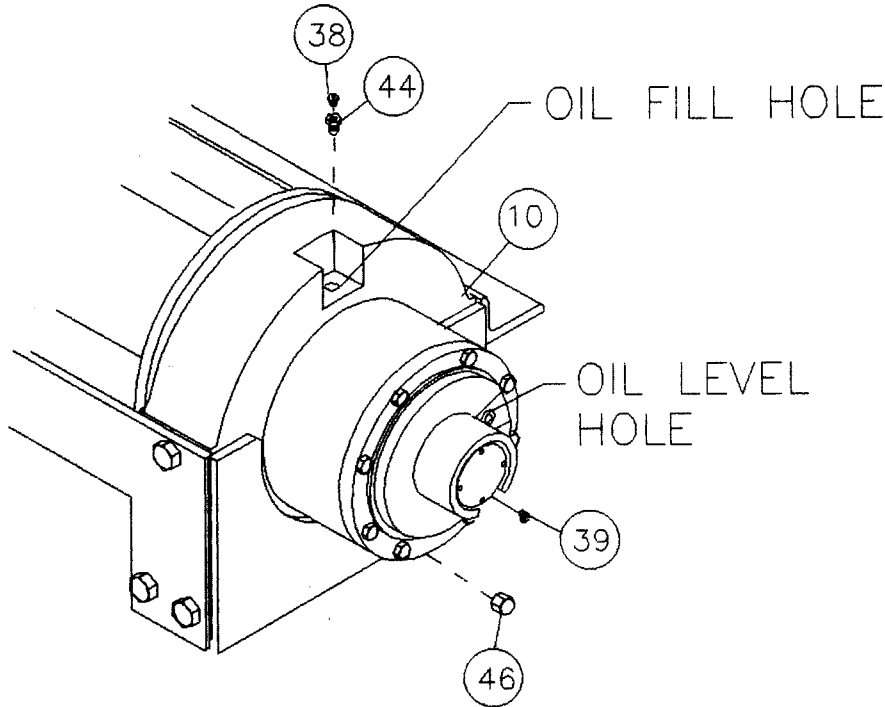

### WINCH MOUNTING CONFIGURATIONS

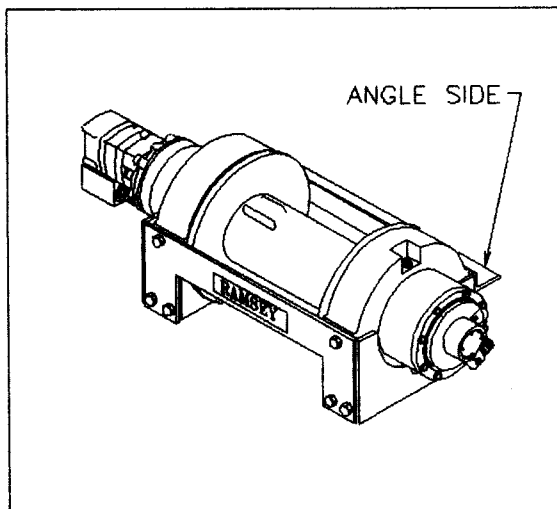

R. H. MOUNTING CONFIGURATION

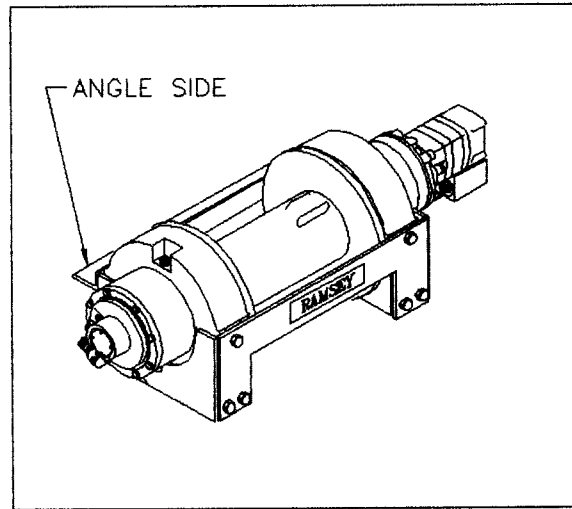

L. H. MOUNTING CONFIGURATION

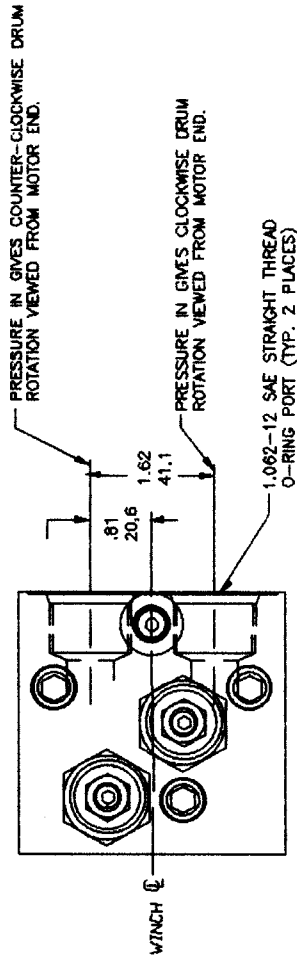

VIEW A-A  
MOTOR CONTROL VALVE DETAIL

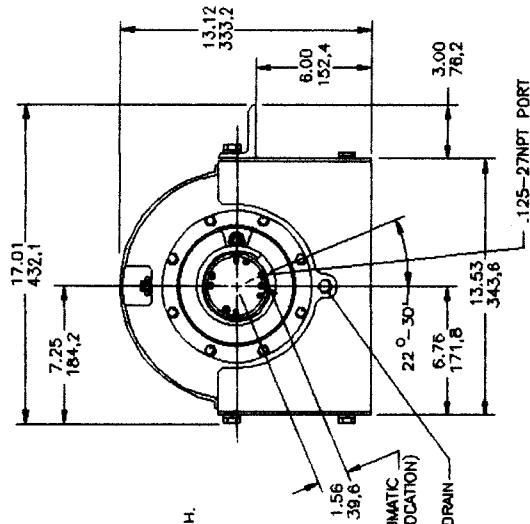
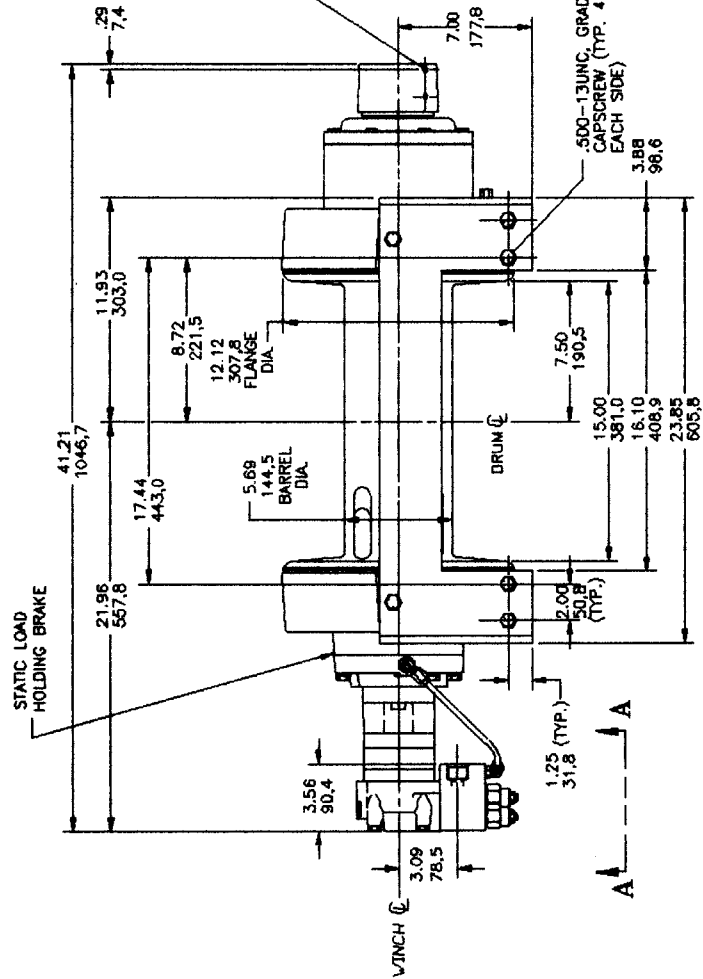

DIMENSIONS SHOWN ARE INCHES OVER MILLIMETERS

# MODEL RPH-25,000

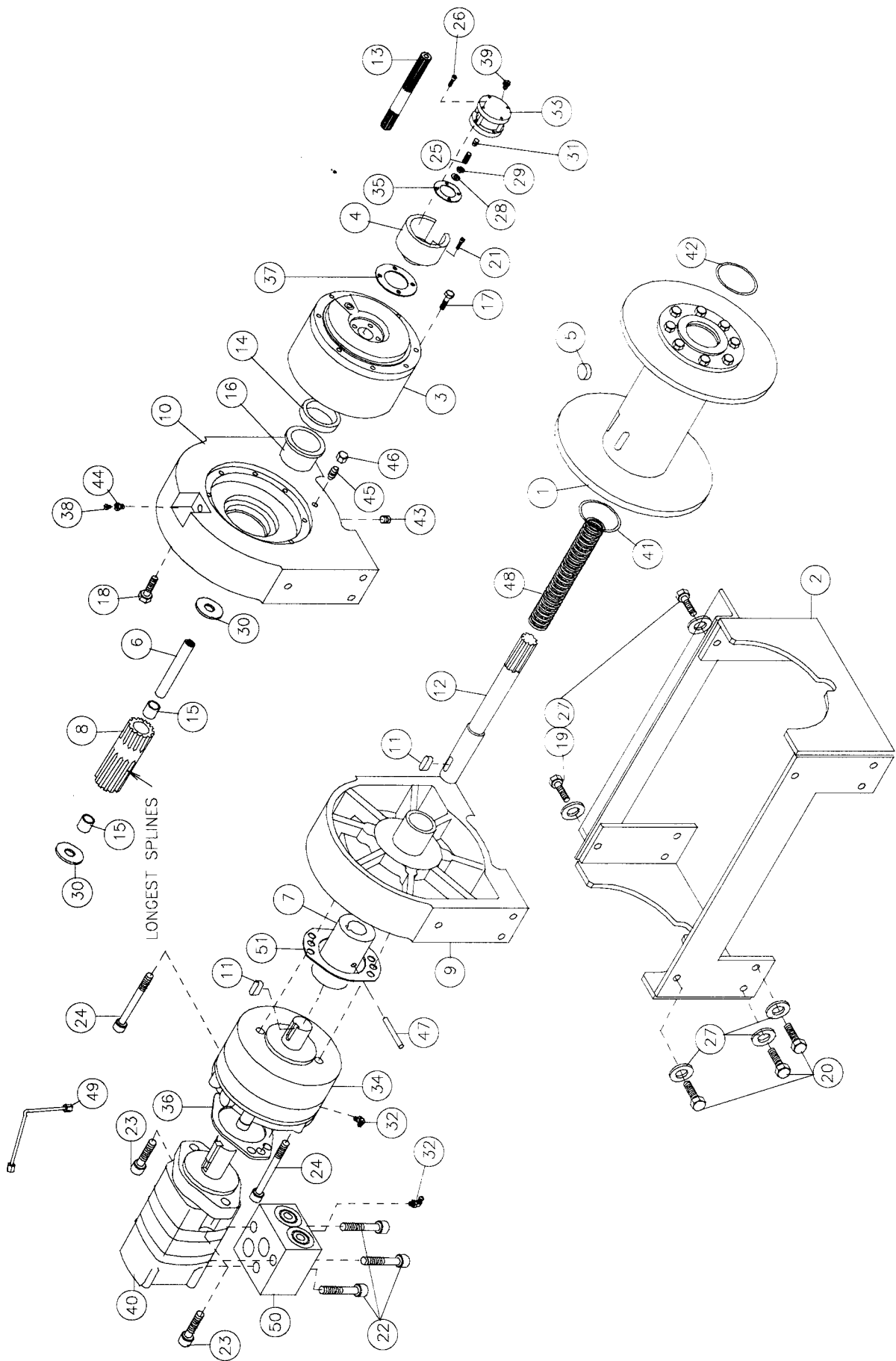

MODEL RPH 25,000

## PARTS LIST FOR RPH-25000

ITEM NO.	QTY.	PART NO.	DESCRIPTION
1	1	234170	DRUM ASSEMBLY
2	1	242157	UPRIGHT MOUNTING FRAME
3	1	296451	GEAR BOX
4	1	300070	ADAPTER-AIR CYLINDER
5	1	314010	CABLE ANCHOR
6	1	324294	COUPLING-SHAFT
7	1	324290	COUPLING-BRAKE
8	1	324293	COUPLING-OUTPUT
9	1	338294	END BEARING-MOTOR
10	1	338299	END BEARING-GEAR
11	2	342194	KEY-RD. END
12	1	357496	SHAFT-INPUT
13	1	358070	SHIFTER SHAFT
14	1	362269	SPACER
15	2	402119	BEARING
16	1	412090	BUSHING-THRUST
17	8	414139	CAPSCREW 5/16-18NC X 1-1/4 LG. HX.HD. GR.5
18	9	414369	CAPSCREW 3/8-24NF X 2-1/4 LG. HX.HD. GR.5
19	2	414564	CAPSCREW 1/2-13NC X 1-1/2 LG. HX.HD.GR.5
20	10	414591	CAPSCREW 1/2-13NC X 1-1/4 LG. HX.HD.GR.8
21	4	414865	CAPSCREW 5/16-18NC X 1 LG. HX.SOC. HD.
22	3	414935	CAPSCREW 3/8-16NC X 2-1/2 LG. HX.SOC.HD.
23	2	414948	CAPSCREW 1/2-13NC X 1-1/4 LG. SOC.HD.
24	2	414958	CAPSCREW 1/2-13NC X 4 LG. SOC.HD.
25	1	416051	SETSCREW 5/16-24NFX 1 LG. SOC.HD.LESS
26	4	416233	CAPSCREW #10-24NC X 2-1/2 LG. HX.SOC.
27	12	418218	LOCKWASHER 1/2 MED.SECT.
28	1	418432	WASHER-THRUST
29	1	418433	NUT-5/16 24NF X 3/16 THK. LOCK
30	2	418462	WASHER-CLUTCH
31	1	426045	INSERT
32	2	432018	FITTING-HYD. 7/16-20 90° ELBOW
33	1	433014	AIR-CYLINDER
34	1	438020	BRAKE
*35	1	442217	GASKET-AIR CYLINDER
*36	1	442215	GASKET-BRAKE
*37	1	442218	GASKET-ADAPTER
38	1	456008	RELIEF FITTING
39	1	456038	BREATHER VENT
40	1	458081	MOTOR-HYD.
*41	1	462012	QUAD-RING
*42	1	462050	QUAD-RING
43	1	468017	PIPE PLUG
44	1	468024	REDUCER
45	1	468036	PIPE NIPPLE
46	1	468037	PIPE CAP
47	1	470091	PIN
48	1	494108	SPRING
49	1	509006	TUBE ASSEMBLY
50	1	516011	VALVE-CONTROL
*51	1	442224	GASKET-BRAKE

\* THESE ITEMS ARE PART OF SEAL AND GASKET KIT #246047. ALSO INCLUDED ARE (3) O-RINGS USED IN DRUM ASSEMBLY 234170, REFER TO PAGE 7.

# Kits and Maintenance Parts

123543

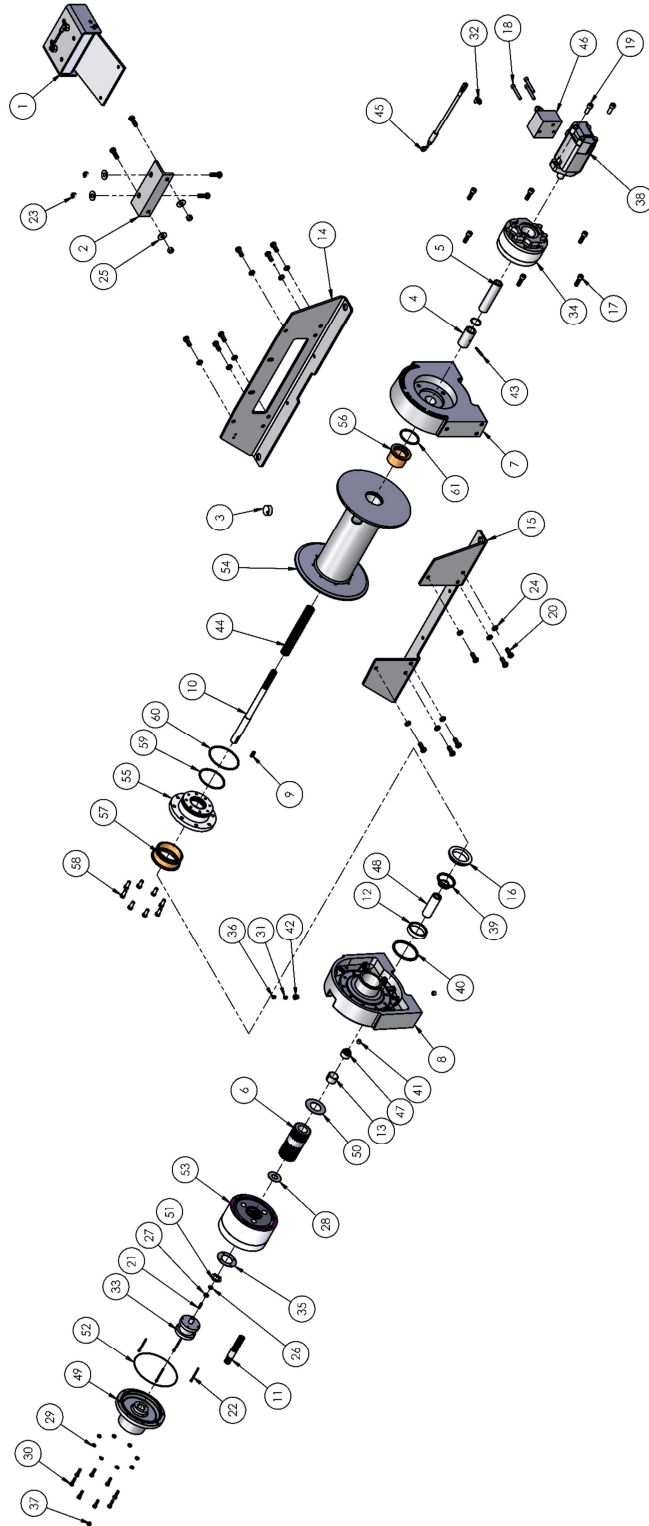

## Kits and Maintenance Parts

**123543**

Item#	QTY.	PART NUMBER	DESCRIPTION	KITS				
				207029	222073	246063	248057	283086
1	1	299708	ASSY-TENSIONER					
2	1	303187	ANGLE-TENSIONER MOUNTING					
3	1	314010	CABLE ANCHOR					
4	1	324290	COUPLING-BRK					X
5	1	324294	COUPLING-SHAFT					
6	1	324299	COUPLING-OUTPUT					
7	1	338294	END BRG-MOTOR					
8	1	338315	END BEARING-GEAR HSG					
9	2	342194	KEY-RD ENDS,5/16X5/16X.990/.975					X
10	1	357496	SHAFT-INPUT					
11	1	358073	SHAFT-INPUT SHIFTER					
12	1	362269	SPACER, STEEL TUBE					
13	2	402119	BEARING-GARLOCK				X	
14	1	408468	SIDE PLATE-REAR					
15	1	408469	SIDE PLATE-FRONT					
16	1	412090	BUSHING-THRUST,SAE 660 BRZ,RPH20000				X	
17	6	414564	CAPSCREW-1/2-13NCX1 1/2LG,HXHD,GR-5					
18	3	414935	CAPSCREW-3/8-16NCX2 1/2,HXSOCHD					
19	2	414948	CAPSCREW-1/2-13NCX1 1/4LG,SOCKET HD	X				
20	10	414591	BOLT-1/2-13NC X1 1/4,HXHD,GR8					
21	1	416051	SETSCREW-5/16-24NF X1,SOCHD,CUP		X			
22	4	416233	SCREW-#10-24NC X 2 1/2, HXSOCHD		X			
23	4	418069	NUT-1/2-13NC HEX REG					
24	12	418218	LOCKWASHER-1/2 ID MED SECT					
25	2	418223	WASHER-1/2 USS FLAT					
26	1	418432	WASHER-THRUST,NYLATRON,5/16 ID					
27	1	418433	NUT-LOCK,5/16-24NF X3/16 THK.		X			
28	2	418462	CLUTCH WASHER 2.125 OD X .878 ID X .070					
29	8	418565	LOCKWASHER-M8					
30	8	420056	CAPSCREW-M8 X 1.25 X 30MM LG, HXHD, GR 10.9					
31	1	426045	INSERT-THREADED,.312-24NF		X			
32	1	432018	FITTING, 7/16-20 90 degree					
33	1	433014	AIR CYLINDER CLUTCH		X			
34	1	438020	BRAKE-MODULAR	X				
35	1	442217	GASKET-AIR CYL			X		

## Kits and Maintenance Parts

123543

				KITS				
Item#	QTY.	PART NUMBER	DESCRIPTION	207029	222073	246063	248057	283086
36	1	456008	RELIEF FIT-1/8-27PFT					
37	1	456038	FITTING-VENT					
38	1	458219	MOTOR-HYDRAULIC					
39	1	462012	QUAD-RING-2 5/8ODX2 1/4IDX3/16			X		
40	1	462050	QUAD-RING			X		
41	2	468017	PIPE PLUG-1/4-18NPTF,HEX SOC HD					
42	1	468024	REDUCER-1/8-1/4 NPTF					
43	1	470091	PIN-SPRING					X
44	1	494108	SPRING-CLUTCH SHIFTER,.192DIA					
45	1	509140	HOSE -4 -4 90DEG 37DEG FLARE 13.8 LENGTH					
46	1	516011	VALVE-MTR CONTROL					
47	2	324285	COUPLING-TUBE,SHAFT					
48	1	324330	TUBE-SHAFT COUPLING					
49	1	328156	COVER-GEAR HOUSING					
50	1	418435	WASHER-SEPARATER,3.25 OD X.060 THK.					
51	1	418443	WASHER-THRUST, .946 ID					
52	1	462063	O-RING, DIA 7.2 OD			X		
53	1	530141	ASS'Y-GEAR BOX,QGBX,25					
54	1	332165	DRUM-CABLE					
55	1	332166	DRIVER-DRUM					
56	1	412091	BUSHING-DRUM,MOTOR END BRG				X	
57	1	412092	BUSHING-DRUM,GEAR HSG.END				X	
58	8	414462	CAPSCREW-7/16-14NCX1LG,HXHD Z/P GR5					
59	1	462052	O-RING, 3 7/8 ID			X		
60	1	462053	O-RING, 4 5/8 ID			X		
61	1	462055	O-RING-3/16X2.75X3.12OD			X		

**RAMSEY WINCH INDUSTRIAL WINCH  
LIMITED WARRANTY**

**1.1 Scope of Warranty Coverage.** Upon the terms and subject to the conditions set forth in this limited warranty:

- (a) RAMSEY WINCH (referred to herein as “**RAMSEY WINCH**” or the “**Manufacturer**”) warrants to each initial end user customer (a “**Purchaser**”) of a new industrial winch together with any accessories manufactured and sold directly from RAMSEY WINCH (the “**Product**”) that the Product shall be free from defects in material and workmanship, under normal working and service conditions, for a period of eighteen (18) months from the date the Product is shipped from RAMSEY WINCH. (the “**Warranty Term**”). A Purchaser shall be eligible for an additional eighteen (18) months of coverage in addition to the Warranty Term (also referred to as the “**Standard (+) PLUS benefit**”) only if the Purchaser (i) complies with Section 1.2(a) and (ii) registers the Product during the Warranty Term at [myproduct.ramseywinch.com](http://myproduct.ramseywinch.com).
- (b) Notwithstanding the foregoing, this warranty does not cover components damaged by accident, abuse, misuse, neglect, untrained operators, collision, overloading, modification, disassembly, rework, misapplication, improper installation, lack of lubrication or maintenance, or improper service. This warranty does not cover the paint or material finish, rope (wire or synthetic), removal or reinstallation of the winch, or normal wear and tear and loss of functionality due to aging of the Product (which may include but is not limited to bearings, bushings, seals, O-rings, gaskets, brake material, motor brushes, electrical cables and more).

**1.2 Eligibility of Warranty Coverage.**

- (a) A Purchaser shall be eligible for warranty coverage under this Limited Warranty during the Warranty Term only if:
  - (i) Prior to placing a Product in service, and throughout use of the Product during the Warranty Term, the Purchaser provides (or causes to be provided) proper storage such that foreign objects (e.g. rain or debris) cannot enter any Product through entry ports which are normally closed during operation.; and
  - (ii) The Purchaser maintains, or causes to be maintained, the Product according to commercially reasonable standards and utilizes the Product for the purposes for which it was created; and
  - (iii) No repairs or alterations have been made by any party other than RAMSEY WINCH, including Purchaser, unless otherwise authorized in writing by RAMSEY WINCH.

**1.3 Transferability of Warranty.**

- (a) This warranty is transferable only from the Purchaser to the first subsequent transferee (the “**Transferee**”) of the Product from Purchaser upon (i) written notification to RAMSEY WINCH and (ii) registration of the transfer, both within 30 days of such Product transfer.
- (b) Upon satisfaction of transfer requirements set forth in Section 1.3(a), the Transferee shall succeed to all the rights and obligations of the Purchaser set forth in this Limited Warranty.

**1.4 Certain Limitations on Scope of Warranty Service.**

- (a) Any obligation of RAMSEY WINCH under this warranty, statutory or otherwise, is limited to the repair of the Product, at its factory or Authorized Service Centers. Notwithstanding the foregoing, if field service or repair is performed by RAMSEY WINCH at the request of the Purchaser and no defect is found with material or workmanship of the Product, the Purchaser shall compensate RAMSEY WINCH for its time and expenses within thirty (30) days of delivery of an invoice relating to the same. If repair is determined by RAMSEY WINCH in its sole, absolute and uncontrolled discretion to be impossible or impractical, then RAMSEY WINCH may satisfy this warranty by replacing the Product. RAMSEY WINCH will not provide any cash payment or credits for defective materials or workmanship.

- (b) Purchaser shall be responsible for any and all freight charges for any Product receiving warranty service under this limited warranty. Any travel time, transportation charges, freight charges, or similar costs incurred by RAMSEY WINCH in connection with the replacement or repair of defective parts, shall, be the responsibility of the Purchaser. If applicable, RAMSEY WINCH shall invoice Purchaser for the total amount of such charges within sixty (60) days of fulfilling its duties under this warranty, payable within thirty (30) days of delivery of such invoice. In no event shall RAMSEY WINCH be liable for bills for service, labor or other expenses that have been incurred by the Purchaser without approval or prior authorization by RAMSEY WINCH for inspection, maintenance, or repair of the Product.
- (c) If a Product is found to be operable upon inspection, the Product, at Purchaser's election, may be either (1) returned to the Purchaser with a service charge from RAMSEY WINCH for inspection, cleaning, and routine replacement of all rubber components and any other parts that show wear; or (2) RAMSEY WINCH can dispose of the product safely.

1.5 **Limitations of Liability.** RAMSEY WINCH shall in no event be liable for punitive, special or consequential damages relating to the Product or this Warranty. RAMSEY WINCH makes no warranty in respect to third-party accessories, upgrades, or additions to the Product.

1.6 **Improving Product.** RAMSEY WINCH reserves the right to improve the Product through changes in design or materials as it may deem desirable or necessary without being obligated to incorporate, upgrade, or otherwise modify previously manufactured products.

1.7 **Limitations of Warranty.**

- (a) THE WARRANTY SET FORTH ABOVE IS THE ONLY EXPRESS WARRANTY. RAMSEY WINCH HEREBY DISCLAIMS AND EXCLUDES ANY OTHER EXPRESS, IMPLIED, OR STATUTORY WARRANTIES, ARISING BY OPERATION OF LAW, COURSE OF DEALING, COURSE OF PERFORMANCE, USAGE, OF TRADE, OR OTHERWISE, INCLUDING, WITHOUT LIMITATION, ANY WARRANTIES OF MERCHANTABILITY, FITNESS FOR A PARTICULAR PURPOSE, AND INTELLECTUAL PROPERTY RIGHTS OF A THIRD PARTY.
- (b) ANY IMPLIED WARRANTY WHICH BY LAW MAY NOT BE EXCLUDED IS LIMITED IN DURATION TO ONE (1) YEAR FROM THE DATE OF ORIGINAL RETAIL PURCHASE OF THE PRODUCT.
- (c) This warranty gives you specific legal rights, and you may also have other rights which vary from jurisdiction to jurisdiction.
- (d) This warranty is valid only in the U.S.A. and Canada. For warranty outside the U.S.A. and Canada contact your nearest Ramsey Winch Distributor.

1.8 **No Modifications to Warranty.** No RAMSEY WINCH dealer, distributor, agent or employee is authorized to make any modification, extension or addition to this warranty.

1.9 **How to Apply for Warranty Coverage.**

All claims are handled by contacting your nearest Ramsey Winch Distributor. For questions, please contact customer support: [rwcustomersupport@ramseyindustries.com](mailto:rwcustomersupport@ramseyindustries.com).

Visit [Dealer Locator - Ramsey Winch](#) for Ramsey Winch Distributor locations and contact information.

Additional warranty, service support, product information, and parts information can be found on [www.ramseywinch.com](http://www.ramseywinch.com).

## NOTES

## NOTES

## NOTES

