



Operating and Maintenance Manual

HD-P 4000

123966 PLANETARY WINCH

OM 914307-0226-H

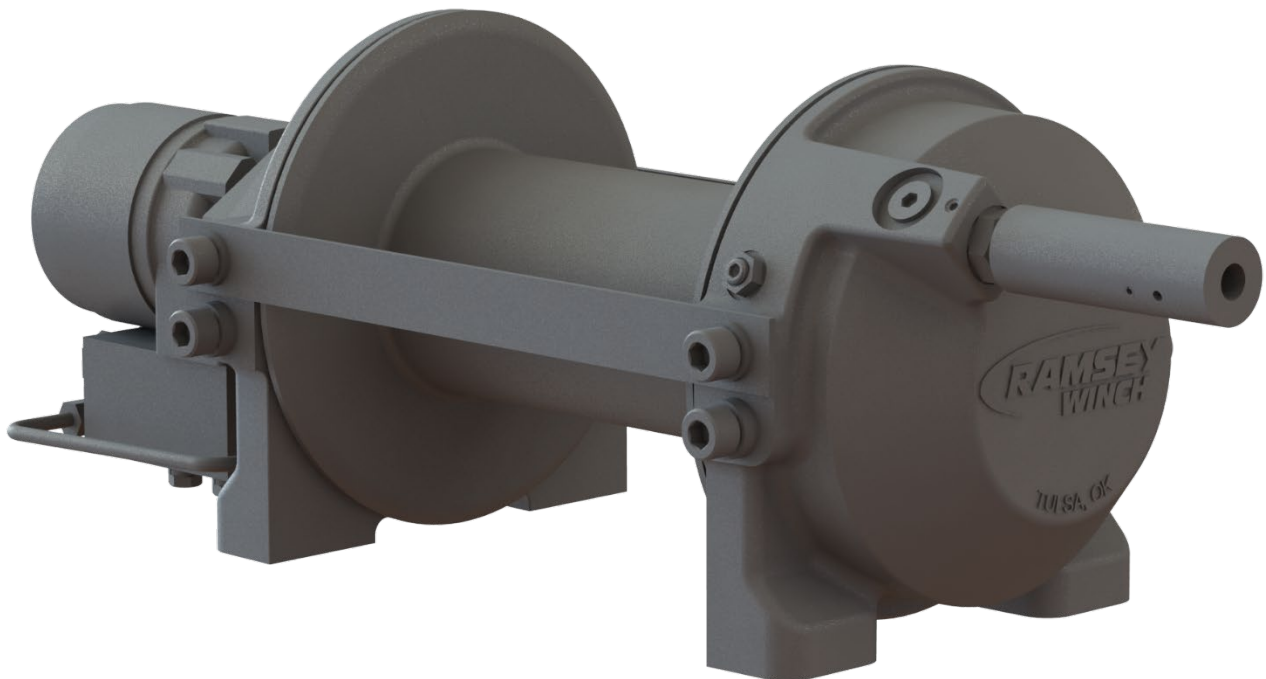

READ AND UNDERSTAND THIS MANUAL BEFORE INSTALLATION AND OPERATION OF WINCH. SEE WARNINGS.

Mailing Address:
P.O. Box 58151
Tulsa, OK 74158

Phone: (918) 438-2760
Fax: (918) 438-6688
www.ramseyindustries.com

Congratulations!

You have purchased the finest winch available in its service class. It was designed and manufactured to provide you with the utmost in utility. As with any device that combines power and movement in its use, there are dangers if improperly used. Please read this manual carefully. It contains useful ideas in obtaining the most efficient operation from your Ramsey Winch and safety procedures you need to know before beginning use. When you follow our guidelines for operation, your Ramsey Winch will give you many years of satisfying service. Thank you for choosing Ramsey. You will be glad you have one working for you.

Table of Contents

Section Title	Page
1.0 Introduction.....	5
2.0 Winch Specifications	7
3.0 Installation Details.....	11
4.0 Winch Operation.....	13
5.0 Maintenance	15
6.0 Troubleshooting Guide.....	17
7.0 Instructions For Overhaul	19
8.0 Parts Identification	23
9.0 Kits and Maintenance Parts	26
10.0 Limited Warranty.....	back cover

THIS PAGE IS INTENTIONALLY LEFT BLANK.

1.0 Introduction

1.1 Introduction

Please read this manual carefully. This manual contains information to obtain the most efficient operation from your Ramsey Winch and safety procedures you need to know before operating a Ramsey Winch. Do not operate this winch until you have carefully read and understand the entire manual. Ramsey Winches are designed and built to exacting specifications. Great care and skill go into every winch we make. Refer to the last page for information on the Ramsey Winch limited warranty. At the time of publishing, this manual is accurate to the best of our knowledge. Ramsey Winch reserves the right to change any or all items, components and parts, necessary for any reason. This right does not obligate Ramsey Winch to immediately update the manual. If in doubt, please call Ramsey Winch for the most up-to-date information.



WARNING

- Do not use the winch in hoisting applications due to required hoist safety factors and features. Do not use the winch to lift, support or otherwise transport people
- Do not allow personnel under or near the load.
- Do not step over or near a cable under a load
- Do not exceed the maximum line pull ratings shown in specifications.
- Ensure that the clutch is fully engaged before starting the winching operation.
- Do not exceed maximum line pull rating shown in tables. Shock loads must not exceed these ratings.
- Use proper personal protective equipment (PPE) including but not limited to gloves and safety glasses when handling winch cable.
- Do not disengage the clutch under load.
- When pulling a heavy load, place a blanket, jacket, or tarpaulin over the cable five or six feet from the hook.
- Modification, alteration, or deviation to the winch should only be made by Ramsey Winch Company.
- Do not try to guide the cable during a loaded pull. Keep yourself and others a safe distance to the side when pulling a load. Do not start the winch motor before engaging the clutch.
- When respooling cable, it is necessary to keep a slight load on the cable. While wearing proper gloves, pull on the cable as the winch is wound in. Do not allow the cable to slip through hands.
- Do not approach the winch too closely.
- Winch clutch should be disengaged when winch is not in use.
- A motorspool (open center) directional control valve is required for brake operation
- A minimum of 5 wraps of steel cable around the drum barrel is necessary to hold the load. **Cable clamp setscrew is NOT designed to hold the load.**
- Do not maintain tension on winch cable during transport. **Do not use winch as a tie down.**



CAUTION

- Avoid conditions where load shifts or jerks occur, as they may indicate a dangerous situation

TIPS FOR SAFE OPERATION

Don't underestimate the potential danger in winching operations.

- Observe spooling of cable onto drum. Side pulls can cause cable to pile up at one end of the drum. To correct uneven stacking, spool out the stacked section of cable and move it to the other end of the drum and continue winching. Uneven spooling of the winch cable can damage the winch.
- Observe your winch while in use while maintaining a safe distance.
- Since the greatest pulling power is achieved on the innermost layer of the winch, it is desirable to pull off as much line as possible for heavy pulls. If necessary, use a snatch block and double line arrangement.
- Tight and neat spooling avoids cable binding.
- **DO NOT ATTEMPT TO WORK AROUND CABLE UNDER LOAD.**

THIS PAGE IS INTENTIONALLY LEFT BLANK.

2.0 Winch Specifications

2.1 Winch Specifications

Rated Line Pull (lbs.).....		4,000			
(Kgs.).....		1,810			
Gear Reduction.....		5.1:1			
Weight (without cable).....		80 lb. (36.3 Kgs.)			
LAYER OF CABLE		1	2	3	4
*Rated line pull per layer	Lbs.	4,000	3,300	2,800	2,500
	Kg.	1,810	1,490	1,270	1,130
*Cable capacity	Ft.	20	45	75	105
	M.	6	13	22	32
*Line speed (at 7 GPM)	FPM	54.0	63.0	73.0	83.0
	MPM	16.1	19.1	22.1	25.2
* These specifications are based on recommended 7/16" (11mm) EIPS wire rope & 6.0 cu.in/Rev. motor at 2850 psi working pressure.					
* Directional control valve: 3-position, 4 way cylinder spool.					
* Winch meets SAE J706.					

NOTE: The rated line pulls shown are for the winch only. Consult the wire rope manufacturer for wire rope ratings.

2.2 Hydraulic System Requirements

- MOTOR SPOOL (OPEN CENTER) CONTROL VALVE REQUIRED
- 2500 PSI RELIEF VALVE SETTING
- 15 GPM FLOW RATE MAX -MOTOR AND WINCH MAY BE DAMAGED IF MAX FLOW RATE IS EXCEEDED
- 10 MICRON NOMINAL FILTRATION

Typical Layout shown below:

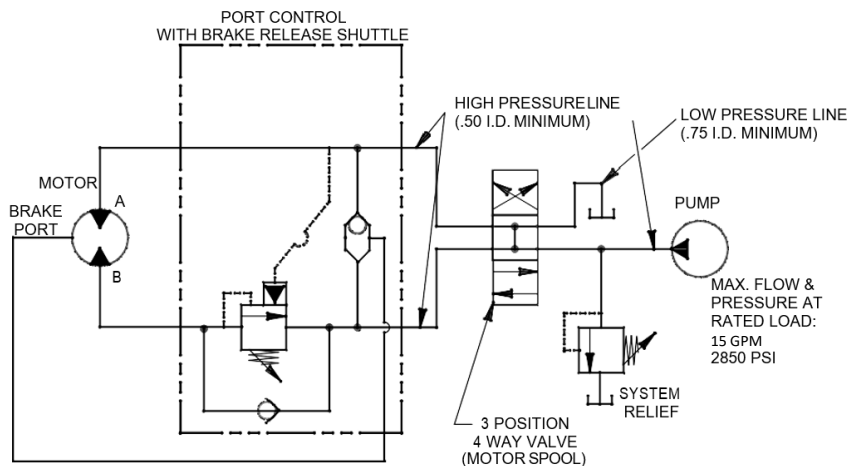

2.0 Winch Specifications

2.3 Performance Charts

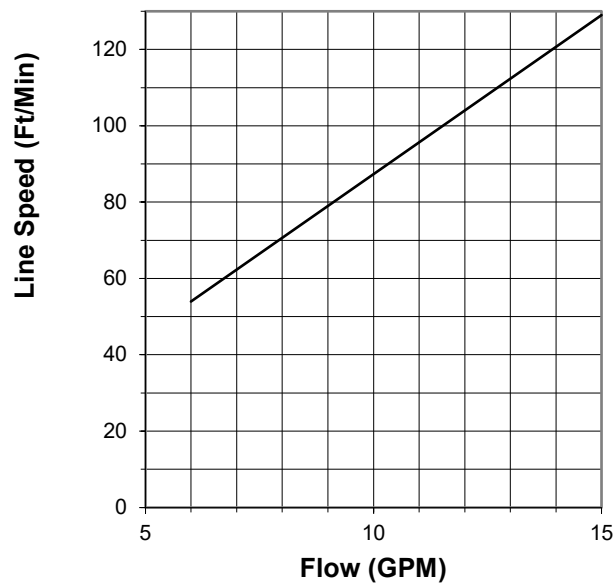
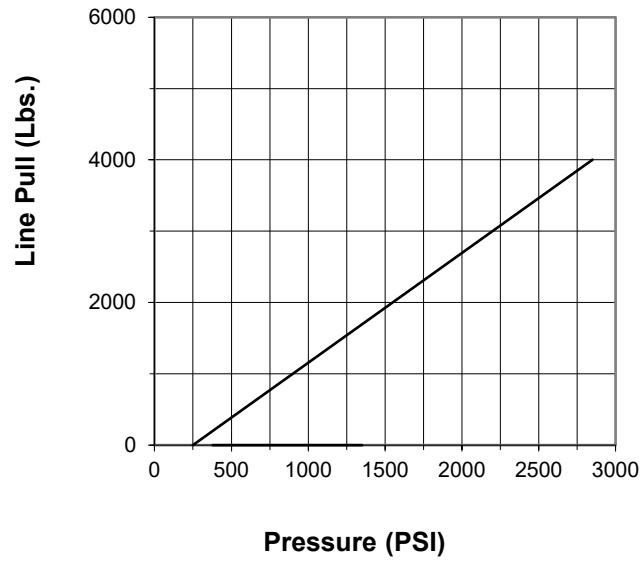

THIS PAGE IS INTENTIONALLY LEFT BLANK.

3.0 Installation Details

3.1 Winch Mounting

ESSENTIAL MOUNTING INSTRUCTIONS TO MAINTAIN ALIGNMENT OF PLANETARY WINCH COMPONENTS:

It is most important that this winch be mounted securely so that the three major sections (the motor end, the cable drum, and the gear housing end) are properly aligned. Excessive bushing wear and difficulty in free-spooling are usually symptoms of misalignment.

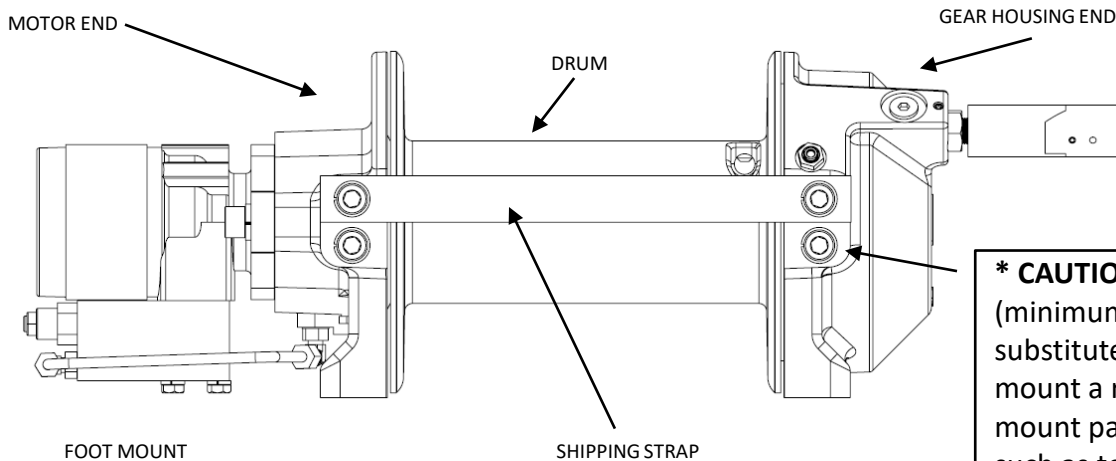

*** CAUTION:** If longer bolts (minimum grade 5) are substituted to mount winch or to mount a roller guide at the side mount pads, bolt length must be such as to allow a minimum of .50 inch thread length engagement in the tapped holes in side of each end bearing. Use of excessive length bolts will damage the winch and prevent free-spool of the drum. Torque bolts to 55 ft-lbs. (75 Nm).

If the winch is foot mounted, then at least one tie-plate must remain mounted at midpoint of winch to maintain alignment. It is always preferred to use BOTH tie-plates in the final installed configuration.

When mounting the winch, the mounting hole patterns described in the Dimensional drawings of this manual should be used. The mounting surface must be flat within .015 inch and sufficiently stiff to resist flexing. If a steel plate is used for foot mounting, it should be .750 inch thick. For this mounting application eight (8) 1/2-13NC x 1-1/2" long grade 5 cap screws with lock washers will be needed to mount winch. Cap screws should be tightened to 55 ft-lb (75 Nm) torque.

NOTE: If angles or a steel plate are used in mounting winch, tie-plates provided with winch should be attached to the remaining mounting pads, whether they be side or foot.

3.0 Installation Details

3.2 Cable Installation

An "A" or "B" decal on the clutch end bearing indicates the spooling direction of the cable. Also, a letter "A" or "B" is stamped in the end bearing on the clutch end indicating rotation direction. If the decal is damaged or unreadable, contact Customer Service for additional instructions to determine proper direction. To reverse the rotation direction, exchange positions of the cartridge and plug shown below.

1. Unwind cable by rolling it out along the ground to prevent kinking. Securely wrap end of cable, opposite hook, with plastic or similar tape to prevent fraying.
2. Place taped end of cable into hole in cable drum as shown below. Use the 3/8-16NC x 1/2" long hex socket drive setscrew to secure cable to drum.
3. Carefully run winch in the "reel-in" direction. Keeping tension on end of cable, spool all the cable onto the cable drum, taking care to form neatly wrapped layers.

After installing cable, check free-spool operation. Disengage clutch and pull on cable at a walking speed. If cable "bird nests", loosen jam nut and turn nylon setscrew clockwise to increase drag on drum. If cable pull is excessive, loosen nylon setscrew by turning counterclockwise. Tighten jam nut when proper setting is obtained.

CAUTION: OVER-TIGHTENING OF JAM NUT MAY STRIP NYLON SETSCREW.

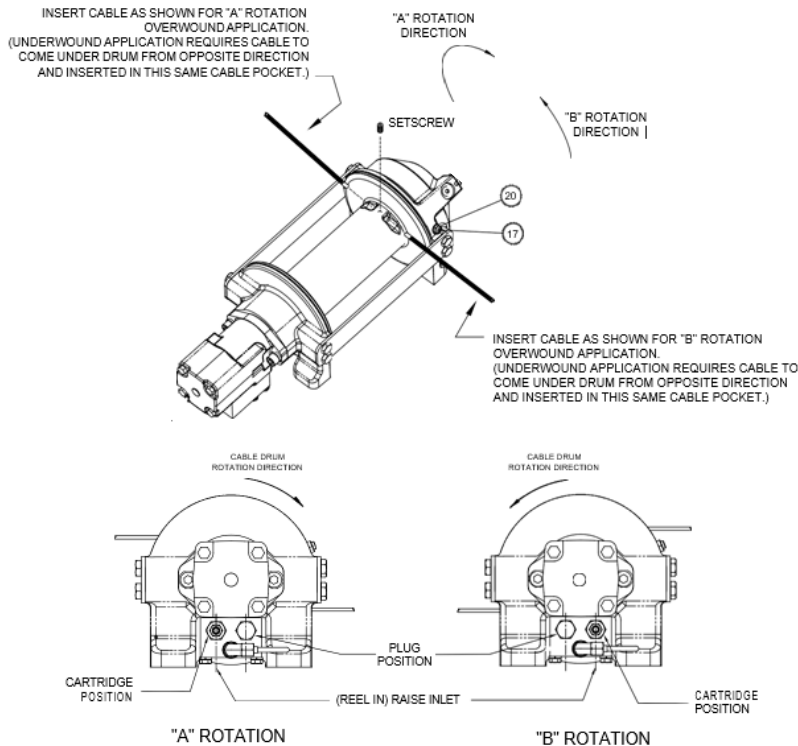

4.0 Winch Operation

4.1 WINCH OPERATION

The best way to get acquainted with how your winch operates is to make test runs before you use it. Plan your test in advance. Remember, you hear your winch as well as see it operate. Get to recognize the sounds of a light steady pull, a heavy pull, and sounds caused by load jerking or shifting. Avoid conditions where load shifts or jerks occur, as they may indicate a dangerous situation.

The uneven spooling of cable, while pulling the load, is not a problem, unless there is a cable pileup on one end of the drum. If this happens, reverse the winch to relieve the load, and move your anchor point further to the center of the vehicle. After the job is done you can unspool and rewind for a neat lay of the cable.

When pulling a heavy load, place a blanket, jacket, and tarpaulin over the cable about five or six feet behind the hook. In the event of a broken cable, this will slow the snap back of the cable and could prevent serious injury.

The winch clutch allows rapid unspooling of the cable, from the cable drum, for hooking onto the load. The clutch is operated by the clutch shifter lever.

WARNING: DO NOT DISENGAGE CLUTCH UNDER LOAD!

TO DISENGAGE CLUTCH: Run the winch in the reverse (reel out) direction until the load is off the cable. Pull handle out and rotate 90°. With handle in the "DISENGAGED" position, cable may now be free-spoiled from the drum.

TO ENGAGE CLUTCH: Pull handle out, rotate 90° and release handle. Run the winch in reverse until the clutch handle snaps fully into the "ENGAGED" position. **DO NOT** attempt to pull a load unless the handle is fully at the "ENGAGED" position.

THIS PAGE IS INTENTIONALLY LEFT BLANK.

5.0 Maintenance

5.1 Maintenance Checklist

- Inspect the cable for damage and lubricate frequently. If the cable becomes frayed with broken strands, replace immediately. Cable must be maintained per the manufacturer's instructions for maintenance. Ramsey Winch does not manufacture cable.
- Check that the clutch is fully engaging. See OPERATION instructions, above, for the appropriate clutch shifter. FOR MANUAL CLUTCH ONLY: Monthly, disengage clutch, put several drops of oil on the clutch handle shaft and work clutch handle IN and OUT several times to lubricate inside the shifter assembly.
- 3. Check to see that the drum cable does not overrun ("bird nest") when free-spooling.
- 4. Replace drum bushings and seals if seals begin to seep grease. Contact Ramsey Winch for further details.

THIS PAGE IS INTENTIONALLY LEFT BLANK.

6.0 Trouble Shooting Guide

CONDITIONS	POSSIBLE CAUSE	CORRECTION/ACTION
DRUM WILL NOT ROTATE AT NO LOAD	Winch not mounted per section 3.0, causing end bearing to bind up Gears damaged	Check mounting. Refer to Winch Mounting. Inspect and replace damaged gears
DRUM WILL NOT ROTATE UNDER LOAD	Winch not mounted squarely, causing end bearing to bind up Load greater than rated capacity of winch Low hydraulic system pressure	Check mounting. Refer to Winch Mounting. Refer to Specifications page for line pull rating. Check pressure. Refer to Hydraulic System and performance charts.
WINCH RUNS TOO SLOW	Low hydraulic system flow rate Motor worn out Clutch not disengaged.	Check flow rate. Refer to Hydraulic System and performance charts. Replace motor Check Operation
DRUM WILL NOT FREESPOOL	Winch not mounted squarely, causing end bearing to bind up Side mounted bolts too long, causing binding of ring gear	Check mounting. Refer to Winch Mounting. Check bolt length. Bolt thread MUST NOT engage threaded holes in sides of end bearing more than the .50 inch thread depth in the end bearing.
BRAKE WILL NOT HOLD	Incorrect directional control valve (cylinder spool- closed center)	Use only a motor spool (open center) control valve.
LOAD DRIFTS	Excessive Backpressure (100 PSI Max.)	Check for restrictions in hydraulic system. Refer to Hydraulic System and performance charts.
CABLE BIRDNESTS WHEN CLUTCH IS DISENGAGED	Drag screw improperly adjusted	Adjust nylon drag screw. Refer to Cable Installation.
EXCESSIVE NOISE	Hydraulic system flow too high Drum in bind, winch not mounted squarely	Check flow rate. Refer to Hydraulic System and performance charts. Check mounting. Refer to Winch Mounting.
DRUM CHATTERS IN "REEL IN" DIRECTION	Low hydraulic system flow rate Low hydraulic system relief pressure setting	Check flow rate. Refer to Hydraulic System and performance charts. Check relief valve setting.
OIL LEAKS FROM BREATHER VENT UNDER MOTOR END BEARING	Damaged brake o-rings, backup rings, or sealing surfaces	Disassemble brake and inspect. Contact Ramsey Winch for details.

THIS PAGE IS INTENTIONALLY LEFT BLANK.

7.0 INSTRUCTIONS FOR OVERHAUL

- 7.1 Remove retaining rings (items #39 & 46) with screwdriver.
- 7.2 Remove brake parts from end bearing. NOTE POSITION OF O-RINGS AND BACKUP RINGS BEFORE REMOVAL. Examine brake discs (items #4) and stators (items #3) for signs of wear, and replace if necessary.
- 7.3 Examine o-rings (items #28 and 29) and backup rings (items #31 and 33) in brake piston (item #5), as well as oring (item #30) and backup ring (item #32) in backup brake piston (item #6) for signs of wear. Remove o-rings and backup rings from grooves in brake piston or backup brake piston and replace if necessary.

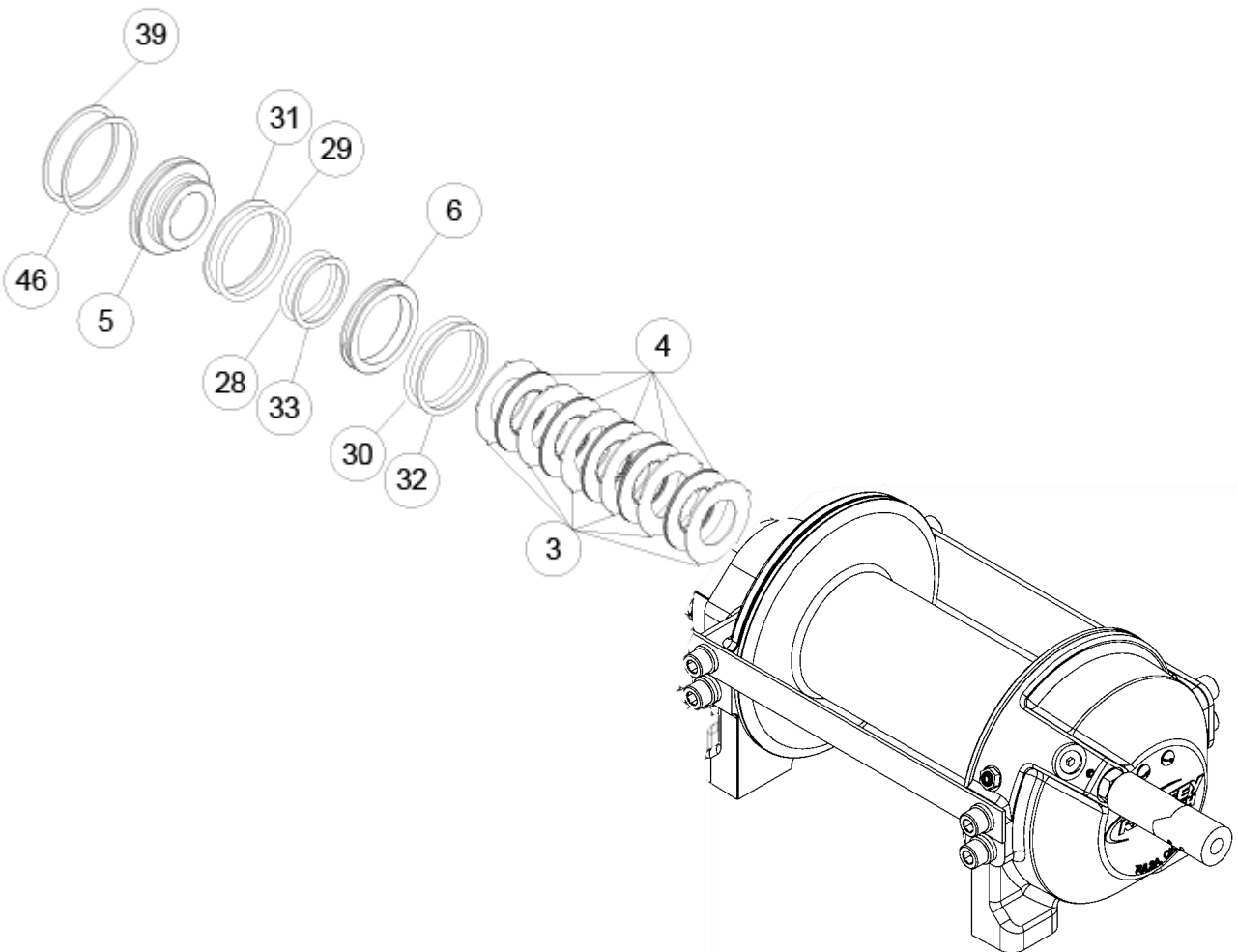

7.0 INSTRUCTIONS FOR OVERHAUL

- 7.4 Remove tie plates (items #11) from end bearings by unscrewing capscrews (items #15). Slide motor end bearing (item #8) and drum (item #1) from gear housing end bearing.
- 7.5 Remove input shaft (item #10) from end bearing. Inspect shaft and output sun gear (item #7) for damage and replace if necessary. To remove the output sun gear, remove the snap rings (items #38) and thrust washer (item #44) and pull off the end of the shaft.
- 7.6 Remove bushing (item #13) and o-ring (item #34) from motor end bearing. Place new, well-oiled o-ring into groove inside of end bearing and press new bushing onto end bearing.

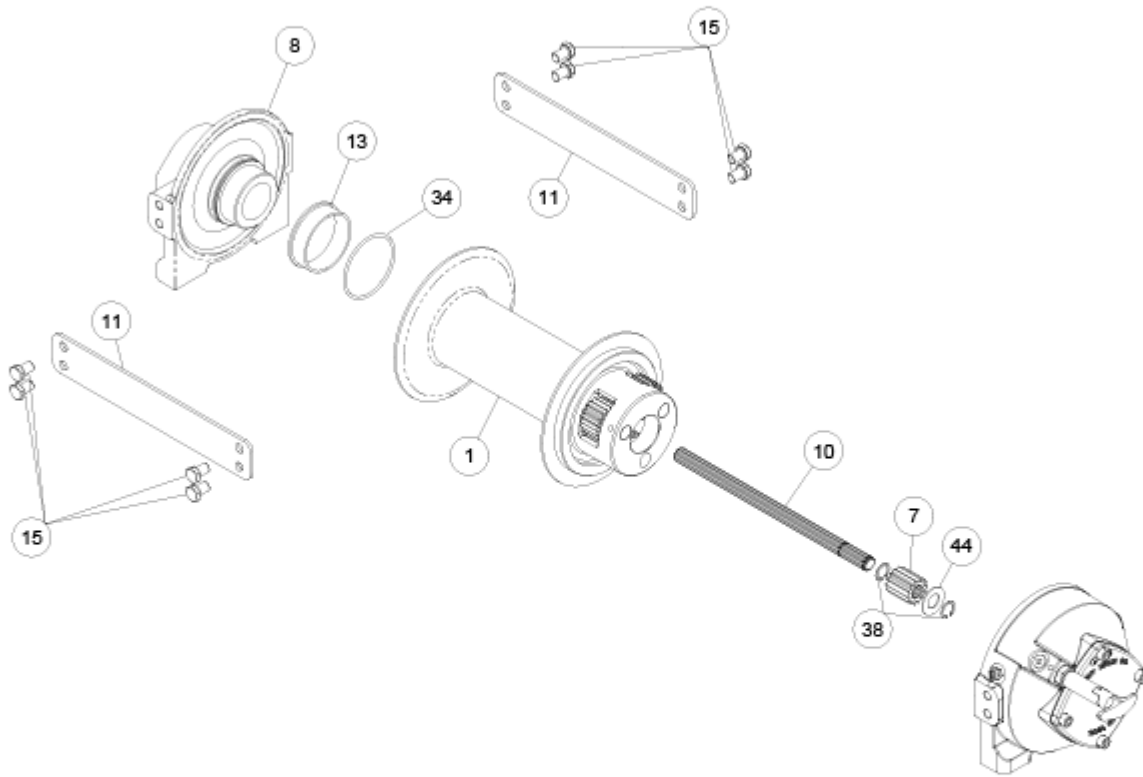

Remove seal (item #37) from gear housing end bearing (item #9). Loosen nut (item #20) and remove nylon setscrew (item #17). Remove ring gear from gear housing end bearing, if necessary. Remove bushing (item #12) from end bearing. Press new bushing into end bearing. Install ring gear, then nylon setscrew and nut. Ring gear must be fully seated in end bearing and slot in ring gear **MUST NOT** be aligned with clutch shifter hole. Install new seal in end bearing, with sharp edge of seal outward.

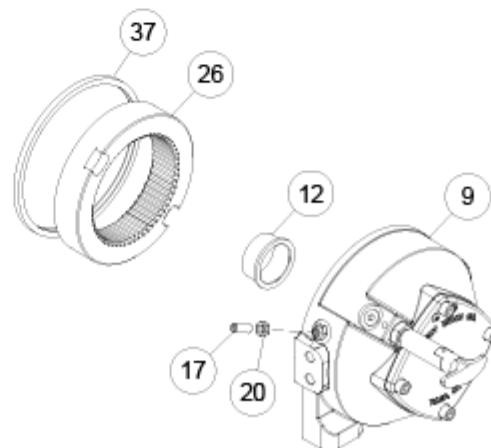

*** Clutch handle shown does not apply to every model.**

7.0 INSTRUCTIONS FOR OVERHAUL

- 7.7 Generously apply grease (MOBILITH SHC 007) to teeth of ring gear (item #26), teeth of planet gears in drum (item #1), and to bushing (item #12) in gear housing end bearing. Apply a small amount of grease to base of bushing (item #13) on motor end bearing. Apply grease to teeth of output sun gear (item #7) and input shaft (item #10).
- 7.8 Place end of shaft with output sun gear on it into drum (item #2). Rotate shaft to engage planet gears with output sun gear. Place Gear End Bearing on Drum and engage planet gears with ring gear.
- 7.9 Assemble motor end bearing (item #8) to drum assembly and use tie plates (items #11) and capscrews (items #15) to hold both end bearings together. Tighten capscrews to 55 ft-lbs (75 Nm).

If necessary, remove and replace the shifter assembly (manual, item #2, or air-cylinder, item #3), as follows:

MANUAL CLUTCH SHIFTER ASSEMBLY

- 7.10 Loosen setscrew (item #19) and jam nut, then unscrew shifter assembly (item #2). Be sure slot in ring gear is not aligned with clutch shifter hole. Rotate drum, if necessary, to ensure hole and slot are not aligned.
- 7.11 Reinstall shifter assembly with plunger, jam nut, and handle positioned in gear housing as shown below. Thread assembly (with handle engaged in cylinder slot) into the gear housing. Pull drum toward the gear end bearing housing to remove play. Hold drum in position and continue threading the shifter assembly in until the gap between the end of the handle and cylinder is $7/16 +0 -1/16$ inch and handle is in the horizontal position (see below). **Note:** This gap will vary with drum endplay. With the drum pulled against the motor end housing, the gap should be $3/8$ inch.
- 7.12 Lightly tighten jam nut. Rotate drum until handle snaps fully into the engaged position. Pull handle out and rotate 90° . Verify that drum can be rotated freely (at least one full revolution) with clutch shifter at the DISENGAGED position. Securely tighten jam nut while holding the handle. Tighten setscrew (item #19) securely. Re-check clutch operation as described on page 5.

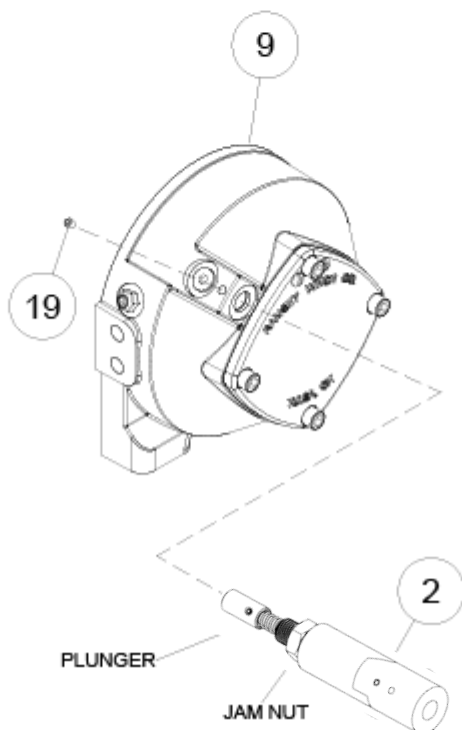

7.0 INSTRUCTIONS FOR OVERHAUL

- 7.13 Set winch with gear housing end down on work surface.
- 7.14 Install well-oiled o-rings and backup rings into grooves on outside of brake piston and backup brake piston as shown in cross-section A-A below.
- 7.15 Piston, backup piston, brake discs and stators must be clean and free of grease and oil.
- 7.16 Insert brake discs (item #4) and stators (item #3) into gear end alternating, with stators first and last.
- 7.17 Insert backup brake piston (item #6) into motor end and insert brake piston (item #5) into it. **Apply even pressure on piston when installing.**
- 7.18 Install retaining rings (items #39 & 46) into grooves in motor end housing.

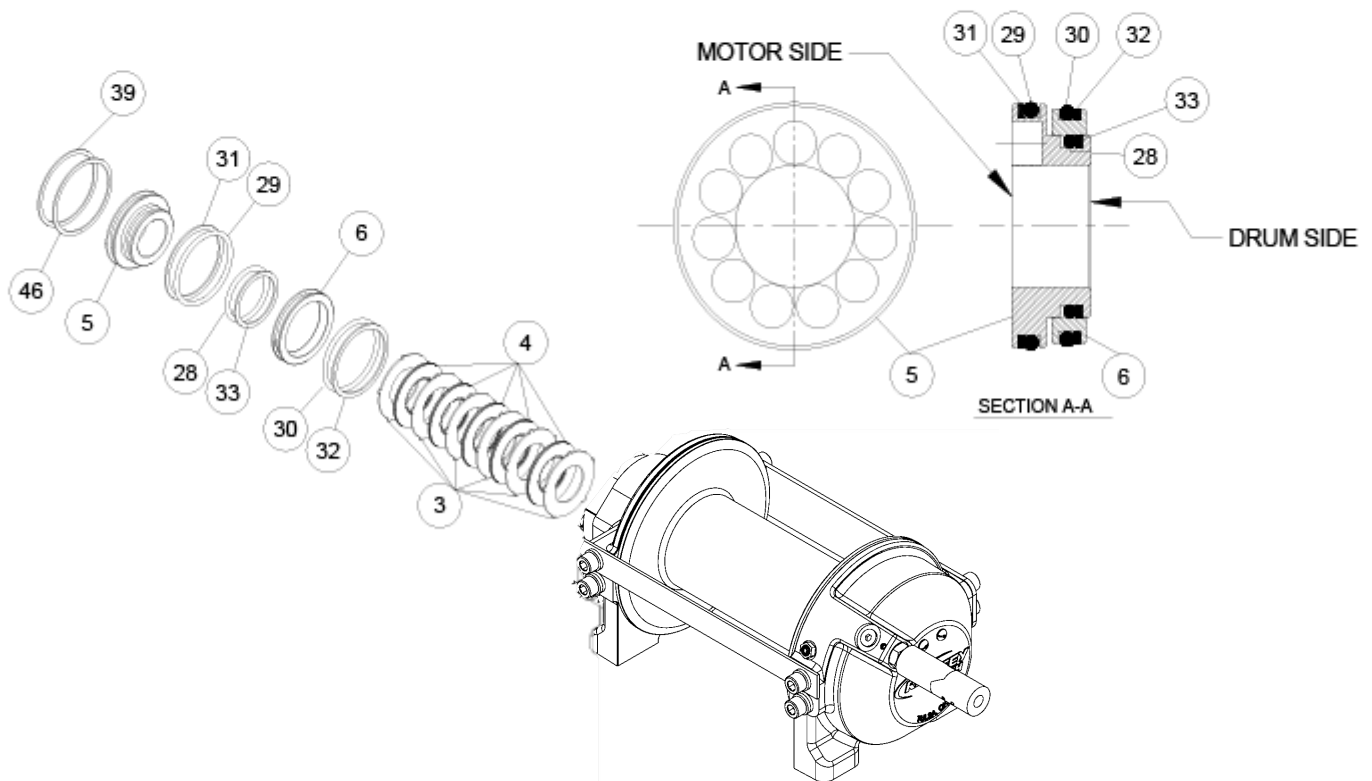

8.0 Parts Identification

8.11 Winch 123966

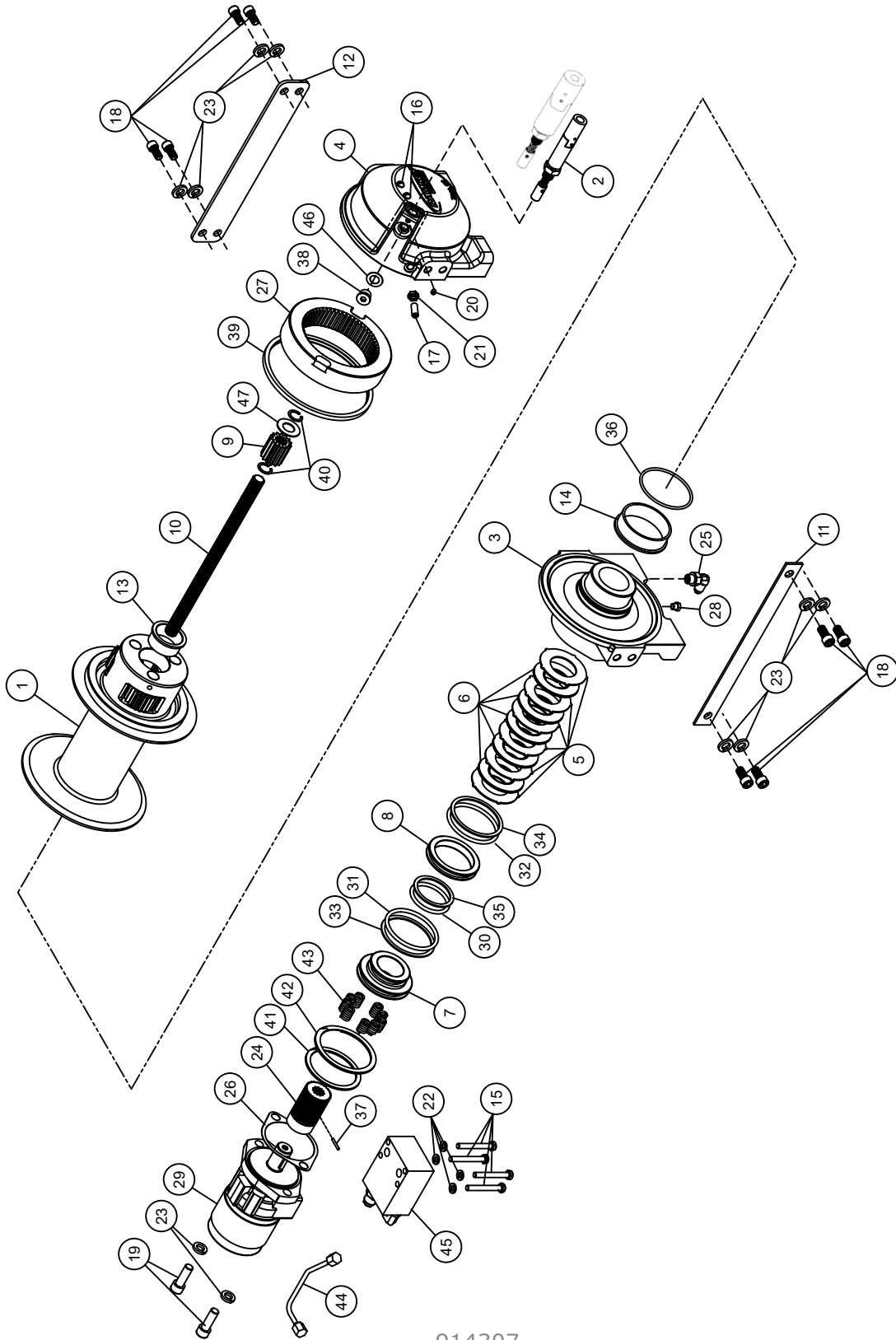

8.0 Parts Identification

8.12 Winch 123966

Item No.	Quantity	Part No.	Description
1	1	234286	ASSEMBLY-DRUM
2	1	276071	SHIFTER ASSEMBLY
3	1	297125	ASSEMBLY-END BEARING, MOTOR SIDE
4	1	297126	ASSEMBLY-END BEARING, GEAR SIDE
5	6	330011	STATOR-BRAKE
6	5	330012	DISC-BRAKE
7	1	330013	PISTON-BRAKE
8	1	330014	PISTON-BACKUP BRAKE
9	1	334174	GEAR-OUTPUT SUN
10	1	357588	SHAFT-INPUT
11	1	364178	STRAP-SHIPPING
12	1	395521	TIE PLATE
13	1	412196	BUSHING-DRUM,GEAR END
14	1	412197	BUSHING-DRUM, MOTOR END
15	4	414159	CS-5/16-18UNCX2.50, HXHD, GR5, ZP, N/P
16	2	414854	SCREW-1/4-20NCX1/2LG, RDHD, SLOT, Z/P
17	1	414926	SETSCREW-3/8-16NC X1, SOCKET, NYLON
18	8	414947	CAPSCREW-1/2-13NC X 1 LG,HEX SOC HD
19	2	414954	CAPSCREW 1/2-13NC X 1/3/4 LG. SOCHD Z/P
20	1	416016	SETSCREW1/4-20NCX1/4 HX SOCK HD CUP
21	1	418036	NUT-3/8-16 NC, HEX JAM, Z/P
22	4	418163	LOCKWASHER-5/16 MED SECT, Z/P
23	12	418218	LOCKWASHER-1/2 ID MED SECT,Z/P
24	1	431019	COUPLING-MOTOR

Item No.	Quantity	Part No.	Description
25	1	432018	FITTING 7/16-20 90 degree
26	1	442223	GASKET-MOTOR FLANGE
27	1	444140	GEAR-RING
28	1	456038	FITTING-VENT, BREATHER
29	1	458227	MOTOR-HYD
30	1	462067	O-RING-2.225 ID X .210 THK, 2-331
31	1	462068	O-RING-3.10 ID X .210 THK, 2-338
32	1	462069	O-RING-2.975 ID X .210 THK, 2-337
33	1	462070	RING-BACKUP, 3.143 ID X .076 THK, 8-338
34	1	462071	RING-BACKUP, 3.018 ID X .076 THK, 8-337
35	1	462072	RING-BACKUP, 2.268 ID X .076 THK, 8-331
36	1	462073	O-RING-3.234 ID X .139 THK, 2-236
37	1	470033	SPIROL PIN-1/8 X 7/8
38	1	472052	PLUG-SAE O-RING,.562-18NF
39	1	486080	SEAL-GEAR HOUSING
40	2	490003	SNAP RING
41	1	490049	RING-INTERNAL RETAINING
42	1	490066	RING-INTERNAL RETAINING
43	9	494124	SPRING-BRAKE
44	1	509132	TUBE-BRAKE RELEASE
45	1	516041	VALVE-MOTOR
46	1	518037	THRUST WASHER
47	1	518047	WASHER-THRUST

THIS PAGE IS INTENTIONALLY LEFT BLANK.

9.0 Kits and Maintenance Parts

123966

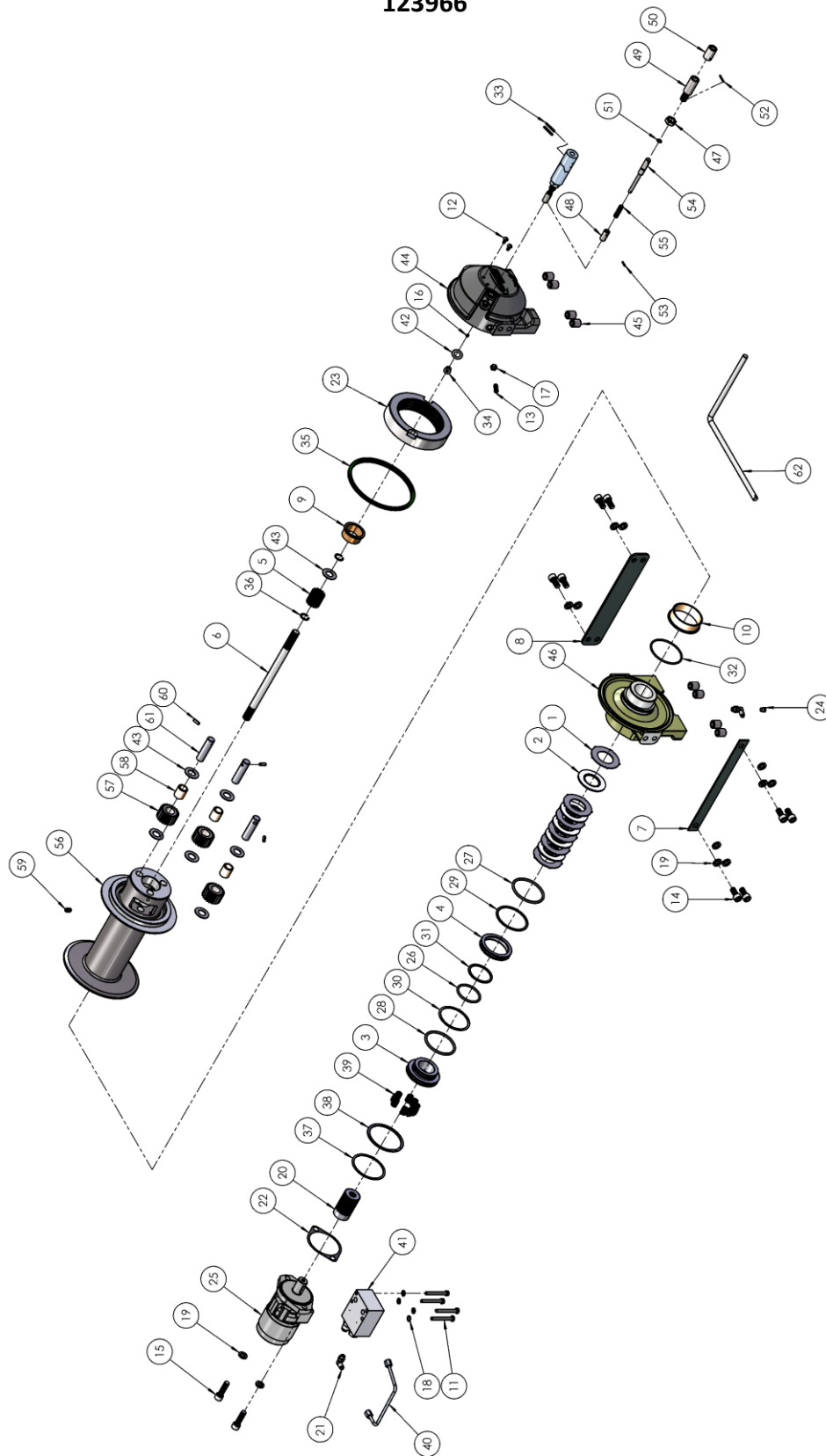

9.0 Kits and Maintenance Parts

123966

Item#	QTY.	PART NUMBER	DESCRIPTION	KITS						
				207023	207025	222075	246065	248065	283089	293032
1	6	330011	STATOR-BRAKE	X						
2	5	330012	DISC-BRAKE	X						
3	1	330013	PISTON-BRAKE		X					
4	1	330014	PISTON-BACKUP BRAKE		X					
5	1	334174	GEAR-OUTPUT,SUN							
6	1	357588	SHAFT-INPUT							
7	1	364178	STRAP-SHIPPING							
8	1	395521	TIE PLATE							
9	1	412085	BUSHING-DRUM,GEAR END					X		
10	1	412109	BUSHING-DRUM, MOTOR END					X		
11	4	414159	CS-5/16-18UNCX2.50,HXHD,GR5							
12	2	414854	SCREW-1/4-20NCX1/2LG,RDHD,SLOT							
13	1	414926	SETSCREW-3/8-16NC X1,SOCKET							
14	8	414947	CAPSCREW-1/2-13NC X 1 LG,HEX SOC HD							
15	2	414954	CAPSCREW 1/2-13NC X 1/3/4 LG. SOCHD							
16	1	416016	SETSCREW1/4-20NCX1/4 HX SOCK HD CUP			X				
17	1	418036	NUT-3/8-16 NC,HEX JAM							
18	4	418163	LOCKWASHER-5/16							
19	12	418218	LOCKWASHER-1/2 ID							
20	1	431019	COUPLING-MOTOR		X				X	
21	2	432018	FITTING 7/16-20 90 degree							
22	1	442223	GASKET-MOTOR FLANGE				X		X	
23	1	444140	GEAR-RING							
24	1	456038	FITTING-VENT,BREATHER							
25	1	458227	MOTOR-HYD							
26	1	462067	O-RING-2.225 ID X .210 THK	X			X			
27	1	462068	O-RING-3.10 ID X .210 THK	X			X			
28	1	462069	O-RING-2.975 ID X .210 THK				X			
29	1	462070	RING-BACKUP, 3.143 ID X .076 THK	X			X			
30	1	462071	RING-BACKUP, 3.018 ID X .076 THK				X			
31	1	462072	RING-BACKUP, 2.268 ID X .076 THK	X			X			
32	1	462073	O-RING-3.234 ID X .139 THK				X			
33	2	470173	PIN-SPRING, 5/32 X 1.25 LG							
34	1	472052	PLUG-SAE O-RING, .562-18NF							
35	1	486109	SEAL-GEAR HOUSING				X			
36	2	490003	SNAP RING							
37	1	490049	RING-INTERNAL RETAINING, 3.250 ID X .061 THK	X						
38	1	490066	RING-INTERNAL RETAINING, 3.466 ID X .054 THK							
39	9	494124	SPRING-BRAKE	X						

9.0 Kits and Maintenance Parts

123966

Item#	QTY.	PART NUMBER	DESCRIPTION							
				07023	07025	22075	46065	48065	83089	93032
40	1	509132	TUBE-BRAKE RELEASE							
41	1	516041	VALVE-MOTOR CONTROL							
42	1	518037	THRUST WASHER					X		
43	7	518047	WASHER-THRUST,.063 THK.X1.50 OD					X		X
44	1	338487	END BEARING GEAR HOUSING							
45	8	416303	THREADED INSERT							
46	1	338486	END BEARING-MOTOR							
47	1	418088	NUT-JAM 5/8-18NF HEX HD			X				
48	1	426042	PLUNGER-CLUTCH			X				
49	1	426084	CLINDER-CLUTCH			X				
50	1	431089	COUPLING-SHIFTER			X				
51	1	462045	O-RING-1/16X1/20D X3/8ID			X	X			
52	1	470033	SPIROL PIN-1/8X7/8			X			X	
53	1	470088	PIN-SPRING			X				
54	1	489015	SHAFT-SHIFTER			X				
55	1	494104	SPRING-SHIFTER			X				
56	1	332301	DRUM							X
57	3	334173	GEAR-OUTPUT,PLANET							X
58	3	412083	BUSHING-PLANET,OUTPUT							X
59	1	416294	SETSCREW3/8-16NCX5/8 HX SOCK HD CUP							
60	3	470086	ROLL PIN-1/4 X 11/16LG							X
61	3	470090	PIN-PLANET							X

**RAMSEY WINCH INDUSTRIAL WINCH
LIMITED WARRANTY**

1.1 Scope of Warranty Coverage. Upon the terms and subject to the conditions set forth in this limited warranty:

- (a) RAMSEY WINCH (referred to herein as “**RAMSEY WINCH**” or the “**Manufacturer**”) warrants to each initial end user customer (a “**Purchaser**”) of a new industrial winch together with any accessories manufactured and sold directly from RAMSEY WINCH (the “**Product**”) that the Product shall be free from defects in material and workmanship, under normal working and service conditions, for a period of eighteen (18) months from the date the Product is shipped from RAMSEY WINCH. (the “**Warranty Term**”). A Purchaser shall be eligible for an additional eighteen (18) months of coverage in addition to the Warranty Term (also referred to as the “**Standard (+) PLUS benefit**”) only if the Purchaser (i) complies with Section 1.2(a) and (ii) registers the Product during the Warranty Term at myproduct.ramseywinch.com.
- (b) Notwithstanding the foregoing, this warranty does not cover components damaged by accident, abuse, misuse, neglect, untrained operators, collision, overloading, modification, disassembly, rework, misapplication, improper installation, lack of lubrication or maintenance, or improper service. This warranty does not cover the paint or material finish, rope (wire or synthetic), removal or reinstallation of the winch, or normal wear and tear and loss of functionality due to aging of the Product (which may include but is not limited to bearings, bushings, seals, O-rings, gaskets, brake material, motor brushes, electrical cables and more).

1.2 Eligibility of Warranty Coverage.

- (a) A Purchaser shall be eligible for warranty coverage under this Limited Warranty during the Warranty Term only if:
 - (i) Prior to placing a Product in service, and throughout use of the Product during the Warranty Term, the Purchaser provides (or causes to be provided) proper storage such that foreign objects (e.g. rain or debris) cannot enter any Product through entry ports which are normally closed during operation.; and
 - (ii) The Purchaser maintains, or causes to be maintained, the Product according to commercially reasonable standards and utilizes the Product for the purposes for which it was created; and
 - (iii) No repairs or alterations have been made by any party other than RAMSEY WINCH, including Purchaser, unless otherwise authorized in writing by RAMSEY WINCH.

1.3 Transferability of Warranty.

- (a) This warranty is transferable only from the Purchaser to the first subsequent transferee (the “**Transferee**”) of the Product from Purchaser upon (i) written notification to RAMSEY WINCH and (ii) registration of the transfer, both within 30 days of such Product transfer.
- (b) Upon satisfaction of transfer requirements set forth in Section 1.3(a), the Transferee shall succeed to all the rights and obligations of the Purchaser set forth in this Limited Warranty.

1.4 Certain Limitations on Scope of Warranty Service.

- (a) Any obligation of RAMSEY WINCH under this warranty, statutory or otherwise, is limited to the repair of the Product, at its factory or Authorized Service Centers. Notwithstanding the foregoing, if field service or repair is performed by RAMSEY WINCH at the request of the Purchaser and no defect is found with material or workmanship of the Product, the Purchaser shall compensate RAMSEY WINCH for its time and expenses within thirty (30) days of delivery of an invoice relating to the same. If repair is determined by RAMSEY WINCH in its sole, absolute and uncontrolled discretion to be impossible or impractical, then RAMSEY WINCH may satisfy this warranty by replacing the Product. RAMSEY WINCH will not provide any cash payment or credits for defective materials or workmanship.

- (b) Purchaser shall be responsible for any and all freight charges for any Product receiving warranty service under this limited warranty. Any travel time, transportation charges, freight charges, or similar costs incurred by RAMSEY WINCH in connection with the replacement or repair of defective parts, shall, be the responsibility of the Purchaser. If applicable, RAMSEY WINCH shall invoice Purchaser for the total amount of such charges within sixty (60) days of fulfilling its duties under this warranty, payable within thirty (30) days of delivery of such invoice. In no event shall RAMSEY WINCH be liable for bills for service, labor or other expenses that have been incurred by the Purchaser without approval or prior authorization by RAMSEY WINCH for inspection, maintenance, or repair of the Product.
- (c) If a Product is found to be operable upon inspection, the Product, at Purchaser's election, may be either (1) returned to the Purchaser with a service charge from RAMSEY WINCH for inspection, cleaning, and routine replacement of all rubber components and any other parts that show wear; or (2) RAMSEY WINCH can dispose of the product safely.

1.5 **Limitations of Liability.** RAMSEY WINCH shall in no event be liable for punitive, special or consequential damages relating to the Product or this Warranty. RAMSEY WINCH makes no warranty in respect to third-party accessories, upgrades, or additions to the Product.

1.6 **Improving Product.** RAMSEY WINCH reserves the right to improve the Product through changes in design or materials as it may deem desirable or necessary without being obligated to incorporate, upgrade, or otherwise modify previously manufactured products.

1.7 **Limitations of Warranty.**

- (a) THE WARRANTY SET FORTH ABOVE IS THE ONLY EXPRESS WARRANTY. RAMSEY WINCH HEREBY DISCLAIMS AND EXCLUDES ANY OTHER EXPRESS, IMPLIED, OR STATUTORY WARRANTIES, ARISING BY OPERATION OF LAW, COURSE OF DEALING, COURSE OF PERFORMANCE, USAGE, OF TRADE, OR OTHERWISE, INCLUDING, WITHOUT LIMITATION, ANY WARRANTIES OF MERCHANTABILITY, FITNESS FOR A PARTICULAR PURPOSE, AND INTELLECTUAL PROPERTY RIGHTS OF A THIRD PARTY.
- (b) ANY IMPLIED WARRANTY WHICH BY LAW MAY NOT BE EXCLUDED IS LIMITED IN DURATION TO ONE (1) YEAR FROM THE DATE OF ORIGINAL RETAIL PURCHASE OF THE PRODUCT.
- (c) This warranty gives you specific legal rights, and you may also have other rights which vary from jurisdiction to jurisdiction.
- (d) This warranty is valid only in the U.S.A. and Canada. For warranty outside the U.S.A. and Canada contact your nearest Ramsey Winch Distributor.

1.8 **No Modifications to Warranty.** No RAMSEY WINCH dealer, distributor, agent or employee is authorized to make any modification, extension or addition to this warranty.

1.9 **How to Apply for Warranty Coverage.**

All claims are handled by contacting your nearest Ramsey Winch Distributor. For questions, please contact customer support: rwcustomersupport@ramseyindustries.com.

Visit [Dealer Locator - Ramsey Winch](#) for Ramsey Winch Distributor locations and contact information.

Additional warranty, service support, product information, and parts information can be found on www.ramseywinch.com.

