

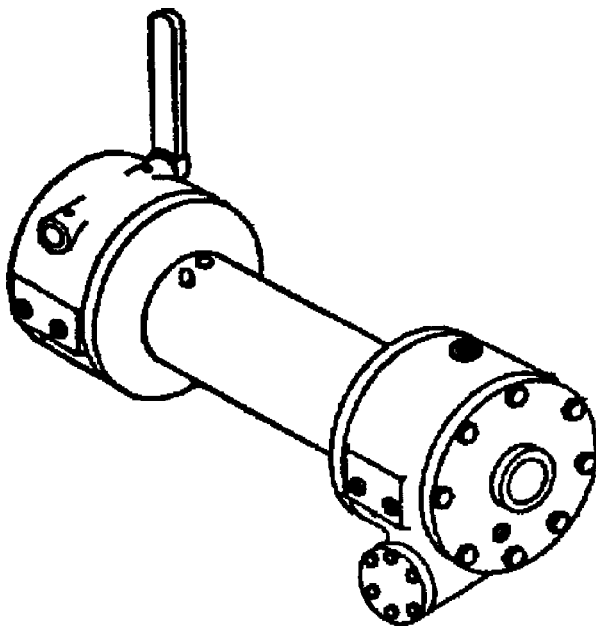

OPERATING, SERVICE AND MAINTENANCE MANUAL



MODEL H-400 LEVER EQUIPPED INDUSTRIAL LOW-MOUNT WINCH



CAUTION: *READ AND UNDERSTAND THIS MANUAL BEFORE
INSTALLATION AND OPERATION OF WINCH. SEE WARNINGS!*

TABLE OF CONTENTS

Introduction	1
Warranty Information	1
Specification	1
Techniques of Operation	2
WARNINGS	2
Winch Maintenance	3
Winch Mounting	4
Cable Installation	4
Hydraulic Systems / Performance Charts	4
Typical Layout / Hyd. System Diagram	5
Trouble Shooting Tips	5
Instructions for Overhaul	6
Disassembly	6-9
Re-Assembly	9-12
Dimensional Drawing	13
Parts List and Parts Drawing	14-15
Limited Warranty	16

RAMSEY WINCH MODEL H-400

PLEASE READ THIS MANUAL CAREFULLY

This manual contains useful ideas in obtaining the most efficient operation from your Ramsey Winch, and safety procedures one needs to know before operating a Ramsey Winch.

WARRANTY INFORMATION

Ramsey Winches are designed and built to exacting specifications. Great care and skill go into every winch we make. If the need should arise, warranty procedure is outlined on the back of your self-addressed postage paid warranty card. Please read and fill out the enclosed warranty card and send it to Ramsey Winch Company. If you have any problems with your winch, please follow instructions for prompt service on all warranty claims. Refer to back page for limited warranty.

SPECIFICATIONS: Conforms to SAE J706

Rated Line Pull 1st layer (Lbs.)		10,000			
(Kgs.)		4,530			
Gear Reduction		29:1			
Shipping Weight		150 lbs. (68 Kgs.)			
LAYER OF CABLE		1	2	3	4**
Rated line pull per layer	Lbs.	10,000	8,200	6,900	6,000
	Kg.	4,530	3,710	3,120	2,710
*Cable capacity per layer	Ft.	25	55	90	130
	M.	7	16	27	39
Line Speed (at 15 GPM))	FPM.	19	23	26	30
	MPM.	5.8	7.0	7.9	9.1

* These specifications are based on recommended cable of 7/16" (11mm) 6 x 19 extra improved plow steel cable.

** Last layer does not conform to SAE J706

NOTE: The rated line pulls shown are for the winch only. Consult the wire rope manufacturer for wire rope ratings.

TECHNIQUES OF OPERATION

The best way to get acquainted with how your winch operates is to make test runs before you actually use it. Plan your test in advance. Remember, you hear your winch, as well as see it operate. Get to recognize the sounds of a light steady pull, a heavy pull, and sounds caused by load jerking or shifting. Gain confidence in operating your winch and its use will become second nature with you.

The uneven spooling of cable, while pulling a load, is not a problem, unless there is a cable pileup on one end of drum. If this happens, reverse the winch to relieve the load and move your anchor point further to the center of the vehicle. After the job is done you can unspool and rewind for a neat lay of the cable.

The winch clutch allows rapid spooling of the cable, from cable drum, for hooking onto a load. The clutch is operated by the handle located on the clutch housing of winch.

1. TO DISENGAGE CLUTCH, run winch in the reverse (reel out) direction until the load is off the cable. Grasp the clutch handle and move it toward the cable drum to the "OUT" position. The cable may now be pulled from the cable drum by hand.
2. TO ENGAGE CLUTCH, move the clutch handle away from the cable drum to the "IN" position, while slowly running the winch in the forward (reel in) direction, until the clutch jaws move into engagement with the drum jaws. When the cable drum starts rotating, stop and make sure that the clutch is engaged and that the clutch handle is fully at the "IN" position. **CLUTCH MUST BE TOTALLY ENGAGED DURING WINCHING OPERATIONS.** The winch is now ready for pulling in the load.

WARNINGS

CLUTCH MUST BE TOTALLY ENGAGED BEFORE STARTING THE WINCH.

DO NOT DISENGAGE CLUTCH UNDER LOAD.

DO NOT LEAVE CLUTCH ENGAGED WHEN WINCH IS NOT IN USE.

STAY OUT FROM UNDER AND AWAY FROM RAISED LOADS.

STAND CLEAR OF CABLE WHILE PULLING. DO NOT TRY TO GUIDE CABLE.

DO NOT EXCEED MAXIMUM LINE PULL RATINGS SHOWN IN TABLE.

WARNINGS (cont'd)

DO NOT USE WINCH TO LIFT, SUPPORT, OR OTHERWISE TRANSPORT PERSONNEL.

A MINIMUM OF 5 WRAPS OF CABLE AROUND THE DRUM BARREL IS NECESSARY TO HOLD THE LOAD. CABLE CLAMP IS NOT DESIGNED TO HOLD LOAD.

WINCH MAINTENANCE

Adhering to the following maintenance schedule will keep your winch in top condition and performing as it should with a minimum of repair.

A. WEEKLY

1. Check the oil level and maintain it to the oil level plug. If oil is leaking out, determine location and repair.
2. Check the pressure relief plug in top of the gear housing. Be sure that it is in good operating condition so that hot oil gases may escape.
3. Lubricate cable with light oil.

B. MONTHLY

1. Lubricate the various grease fittings located in the cable drum, end bearing, clutch housing or clutch operating linkage. Any good grade of moly-disulfide containing grease is acceptable.
2. Check the action of the sliding clutch, making sure it is fully engaging and disengaging with the cable drum. Observe the jaws on both the clutch and cable drum, checking for rounding of the driving faces. If rounding has occurred they should be replaced immediately.
3. Check the winch mounting bolts. If any are missing, replace them and securely tighten any that are loose. Make sure to use only grade 5 bolts or better.
4. Inspect the cable. If the cable has become frayed with broken strands, replace immediately

C. ANNUALLY

1. Drain the oil from the winch annually or more often if winch is used frequently.
2. Fill the winch to the oil level plug with clean kerosene. Run the winch a few minutes with no load in the reel in direction. Drain the kerosene from the winch.
3. Refill the winch to the oil level plug with all purpose E.P. 140 gear oil.
4. Inspect frame and surrounding structure for cracks or deformation.
5. Gear wear can be estimated by rocking the drum back and forth and if necessary drain oil and remove cover for closer inspection.

WINCH MOUNTING

It is most important that this winch be mounted securely so that the three major sections (the clutch housing end, the cable drum and the gear housing end) are properly aligned.

CABLE INSTALLATION

1. Unwind cable by rolling it out along the ground to prevent kinking. Securely wrap end of cable, opposite hook, with plastic or similar tape to prevent fraying.
2. Insert the end of cable, opposite hook end, into the 1/2" dia. hole in drum barrel. Secure cable to drum barrel, using setscrew furnished with winch. TIGHTEN SETSCREW SECURELY.
3. Carefully run winch in the "reel-in" direction. Keeping tension on end of cable, spool all the cable onto the cable drum, taking care to form neatly wrapped layers.

HYDRAULIC SYSTEMS

Refer to the performance charts, below, to properly match your hydraulic system to the H-400 Series winch performance. The charts consist of:

- (1) Line speed, first layer (F.P.M.) vs. gallons per minute (G.P.M.) and
- (2) Line pull (lbs.) first layer vs. working pressure (P.S.I.). **STATIC** (solid line) refers to hoisting a suspended load from rest; **DYNAMIC** (dotted line) refers to maintaining the motion of a moving load.

Performance based on a motor displacement of 6.2 cubic inches with 15 GPM maximum flow rate.

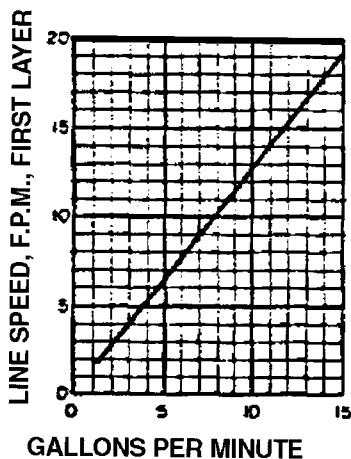
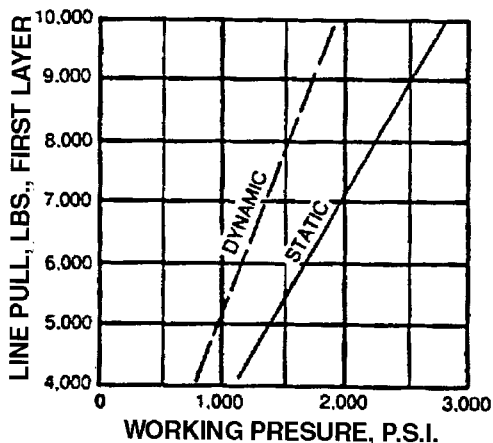

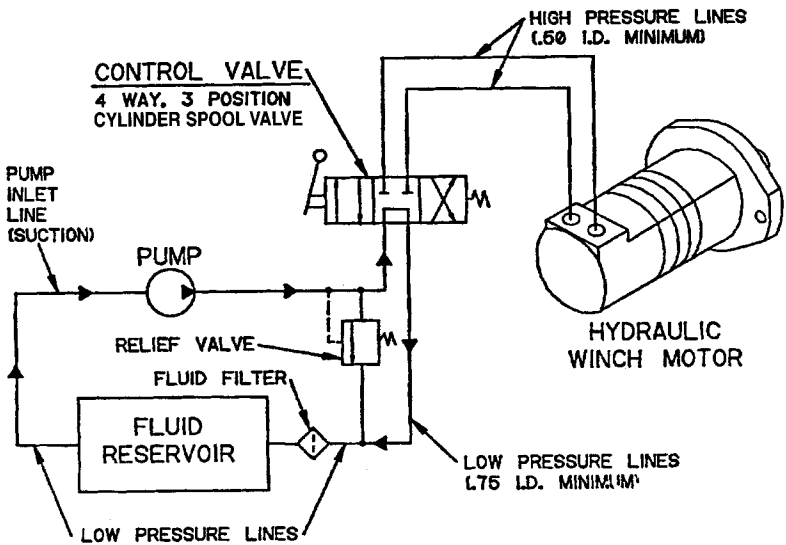

TROUBLE SHOOTING TIPS

CONDITIONS	POSSIBLE CAUSE	CORRECTION
Clutch inoperative or binds up.	<ol style="list-style-type: none"> 1. Dry or rusted shaft. 2. Bent yoke or linkage. 3. Clutch jaws are in contact. 	<ol style="list-style-type: none"> 1. Clean and lubricate. 2. Replace yoke or shaft assembly. 3. See TECHNIQUES OF OPERATION.
Oil leaks from housing.	<ol style="list-style-type: none"> 1. Seal damaged or worn. 2. Too much oil. 3. Damaged gasket. 	<ol style="list-style-type: none"> 1. Replace seal. 2. Drain excess oil. Refer to WINCH MAINTENANCE. 3. Replace gasket.
Winch runs too slow.	<ol style="list-style-type: none"> 1. Hydraulic motor worn out. 2. Low flow rate. 	<ol style="list-style-type: none"> 1. Replace motor. 2. Check flow rate. Refer to Hydraulic Systems flow chart pg. 4.
Cable drum will not freespool.	<ol style="list-style-type: none"> 1. Winch not mounting squarely, causing end bearings to bind drum. 	<ol style="list-style-type: none"> 1. Check mounting. Refer to WINCH MOUNTING pg 4.
Cable birdnests when clutch is disengaged.	<ol style="list-style-type: none"> 1. Drag brake disk worn. 	<ol style="list-style-type: none"> 1. Replace discs.

Instructions for Overhaul of Ramsey Model H-400 Lever Style Winch.

Disassembly

Refer to parts list and parts drawing pages for actual item numbers and corresponding part numbers.

1. Drain oil from gear housing by removing (item #42) plug from bottom of gear housing. Remove relief fitting and reducer (items #38 & #40) from top of gear housing.

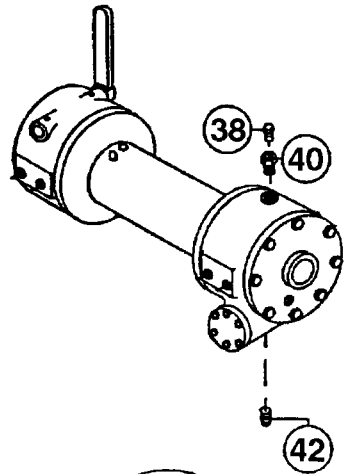

2. Slide clutch housing (item #10) from end of drum shaft. Remove setscrew, spring and poppet ball (items #29, #44, and #21) from jaw clutch (item #5). Slide jaw clutch from end of drum shaft.

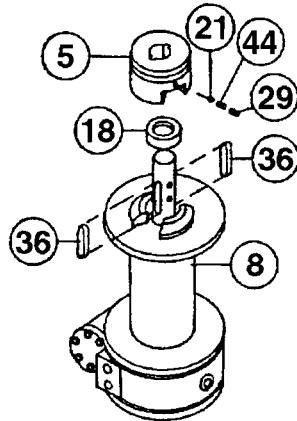
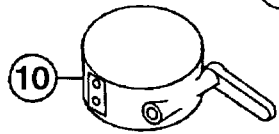

Remove two keys (item #36) from keyways. Once keys have been removed, drum (item #8) and drum spacer (item #18) can be removed from drum shaft.

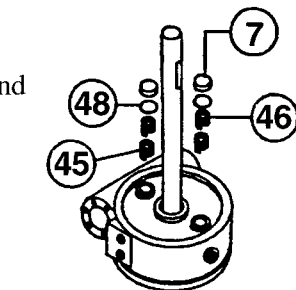

3. Drag brake disc (item #7), spacer (item #48) and springs (item #45 & #46) should be examined and replaced if necessary.

4. Remove motor from adapter (item #1). Remove adapter (item #1) from gear housing by removing six (item #28) capscrews. Replace seal (item #43) and gasket (item #34). Remove thrust bearing (item #23) and thrust washers (item #47).

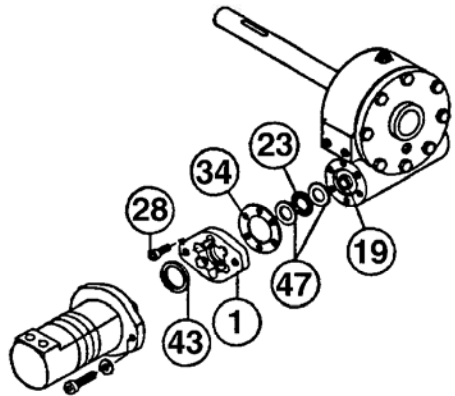

5. Remove bearing cap (item #4) from gear housing by unscrewing six capscrews (item #26). Remove worm (item #19) and bearing (item #22) from gear housing. Use a soft hammer to gently tap input end of worm and drive worm and bearing from gear housing. Once worm has been removed from housing, bearing can be pressed from end of worm. Check for signs of wear or damage to worm (item #19) and bearing (item #22). Replace if necessary.

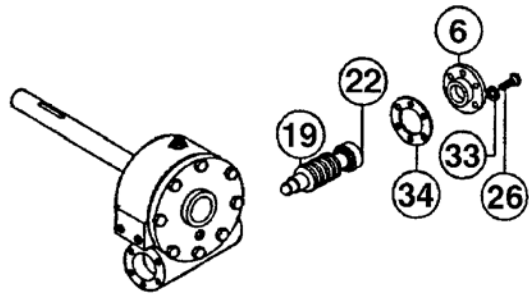

6. Remove gear housing cover (item #6) from gear housing (item #11) by unscrewing eight capscrews (item #27). Thread two of the capscrews into the two tapped holes of cover and tighten. This will pull the cover loose from gear housing. Remove cover gasket (item #35) and pull shaft (item #15), with gear attached, from gear housing.

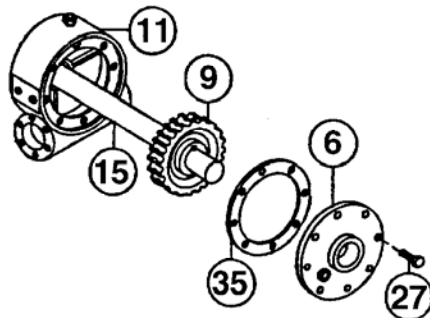

7. Check gear teeth for signs of wear.

Replace if necessary by pressing gear (item #9) from shaft. Press new gear over shaft and keys until end of keys, on long end of shaft, are flush with gear. Examine shaft, keys and keyways. If distortion of keys and/or keyways are evident, shaft and keys should be replaced. Tap keys (item #14) into shaft keyways. Press gear over shaft and keys until end of keys, on long end of shaft, are flush with gear.

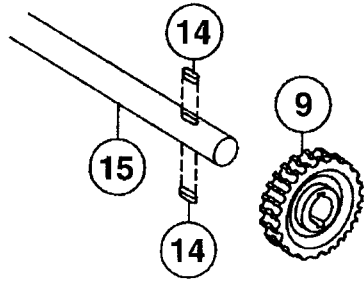

8. Check gear housing bushing (item #3) and quad ring (item #39) for signs of wear. Replace if necessary by pressing old bushing from gear housing. Press new bushing into place and insert new quad ring into groove inside of bushing.

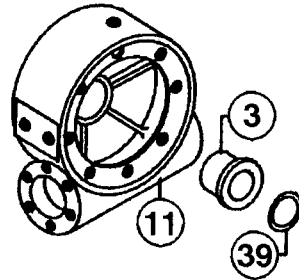

9. Check drum bushings (items #2 & #25) for signs of wear. Replace if necessary by pressing old bushings from drum. Press new ones into place. NOTE: If bushings are replaced, it will be necessary to run a 9/16 (.56) dia. drill through cable pocket. The following drum assemblies are available with new bushings pressed in place and predrilled; (#234141) 400 Series drum assembly.

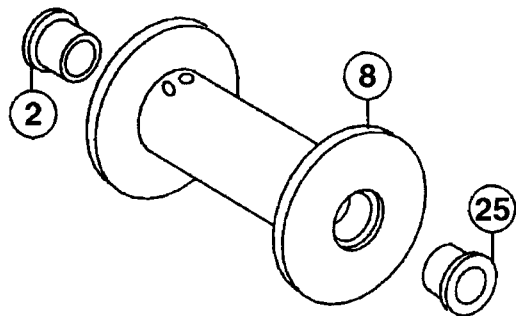

10. Check clutch housing bushing (item #24) for wear. If necessary, remove old bushing and press new bushing into place. Apply grease to lube fittings (item #37) to lubricate clutch shifter shaft.

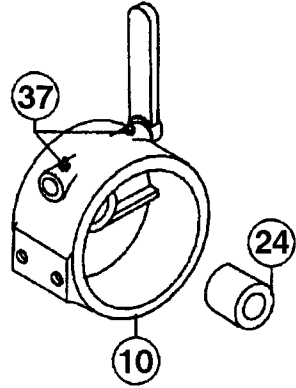

11. Check cover bushing (item #3) and quad ring (item #39) for signs of wear. if necessary remove old bushing and press new bushing into place and insert new quad ring into groove inside of bushing.

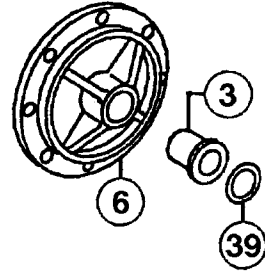

RE-ASSEMBLY

12. Apply grease to end of shaft, opposite gear. Apply grease to bushing in gear housing (item #11). Place greased end of shaft through bushing in gear housing (item #11). Place gasket (item #35) onto gear housing cover (item #6). Apply grease to gear end of shaft and cover bushing. Place cover onto shaft and secure to housing with eight (item #27) capscrews. Tighten capscrews to 12 ft. lbs. (16.1.Nm.) each.

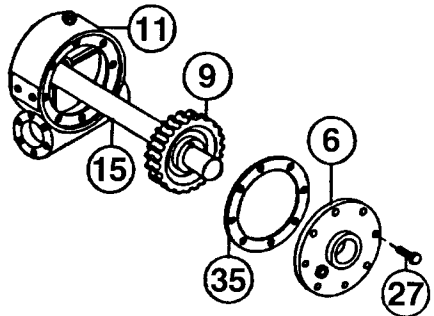

13. Press bearing (item #22) onto worm (item #19). NOTE: Be sure that thick shoulder of bearings outer race (side with manufacturer's name and part number) is out, away from worm threads. Press bearing and worm into gear housing. Slip gasket (item #34) onto bearing cap (item #4). Use six capscrews (item #26) and lockwashers (item #33) to secure cap to gear housing. Tighten capscrews to 12 ft. lbs. (16.1.Nm.) each.

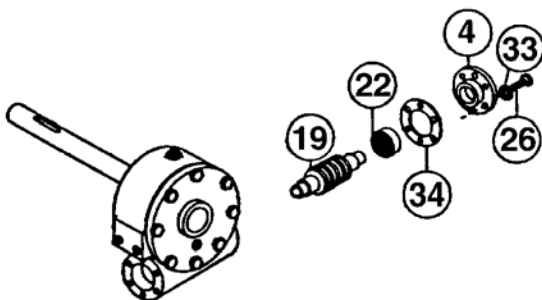

14. Place thrust washers (item #47) and thrust bearing (item #23) over end of worm (item #19) and into housing. Attach adapter (item #1) with gasket (item #34) to housing, using six (item #28) capscrews. Tighten capscrews to 12 ft. lbs. (16 Nm.) each. Insert new seal (item #43) into adapter and carefully place motor shaft, with key in keyway, through seal, so as not to damage seal. Insert motor shaft into end of worm (item #19). Secure motor to coupling using two capscrews with lockwashers. Tighten capscrews to 39 ft. lbs. (53 Nm.) each.

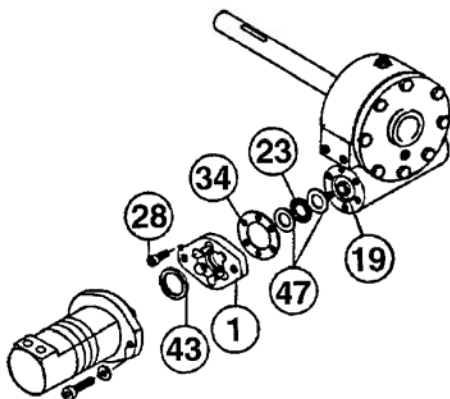

15. Place winch with gear housing cover down on work bench. Drum shaft should be in vertical position. Set springs (items #45 & #46) into pockets of gear housing with drag brakes (item #7) on top of disc (item #48) and springs. Slide drum assembly (item #8) onto drum shaft with drum jaws upward.

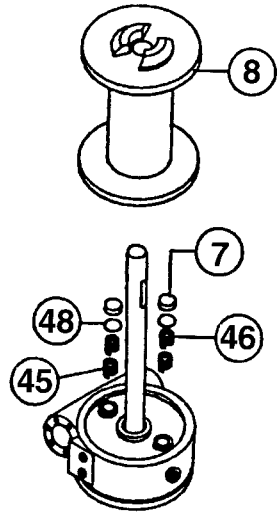

16. Slide spacer (item #18) over end of drum shaft. Press drum downward to compress drag brake springs in gear housing. Insert keys (item #36) into keyways. A rubber or brass mallet will be needed to gently tap keys into position. Apply grease to keys and end of shaft. Place jaw clutch (item #5) over end of shaft and slide jaw clutch over keys.

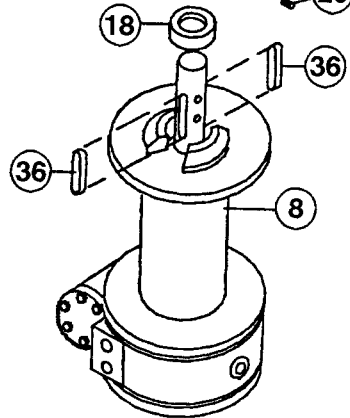
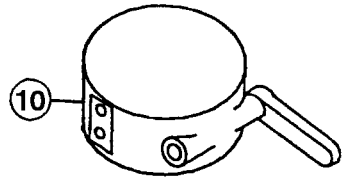

NOTE: Be sure that tapped hole on side of jaw clutch is on same side of shaft as the two ball detents. Insert ball poppet (item #21), spring (item #44) and setscrew (item #29) into tapped hole of jaw clutch.

If jaw clutch and, or drum shaft have been replaced two new detents MUST be drilled as follows:

Slide jaw clutch over end of shaft. Engage jaws of clutch with jaws of drum. Use a 3/8" dia. drill, using

hole in jaw clutch as a guide, to drill a 1/8" deep detent (as measured to the center of the drill point) in shaft. Slide jaw clutch upward 15/16" and drill second detent.

If only the clutch is replaced, the new detents are to be drilled on the side of the shaft opposite the old detents. Apply grease to bushing in clutch housing assembly (item #10). Set clutch housing onto end of drum shaft. Pull jaw clutch upward, toward clutch housing, enough to allow yoke in clutch housing to fit properly in groove around jaw clutch. Slide clutch housing assembly and jaw clutch downward into place.

The setscrew should be tightened enough to allow ball, when placed in ball detents, to sufficiently hold jaw clutch "IN" and "OUT".

18. Insert plug (item #42) into bottom of gear housing. Permatex may be applied to threads to help prevent leakage.

Pour 1-1/2 pints of EP 140 gear oil into housing through hole in top of housing. Insert relief fitting (item #38) into reducer (item #40). Reducer should then be placed into hole on top of gear housing. Tighten fittings and reducer securely.

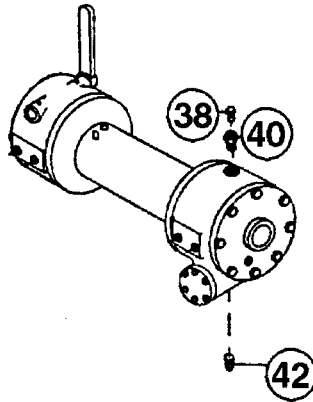

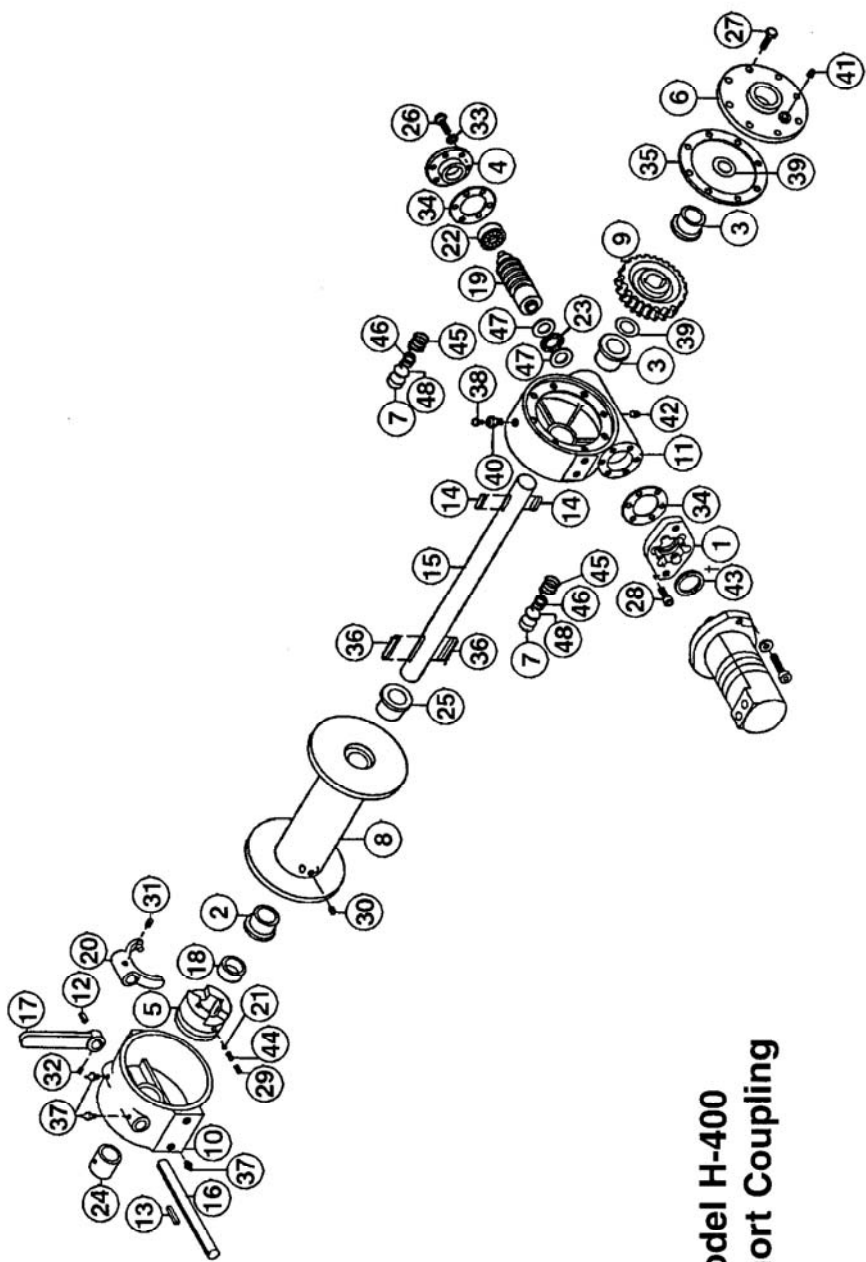

**Model H-400
Short Coupling**

PARTS LIST - Model H400 SC SHORT COUPLING

ITEM	QTY.	PART NO.	DESCRIPTION	ITEM	QTY.	PART NO.	DESCRIPTION
1	1	300062	Adapter	27	8	414140	Capscrew-5/16-18 NC X 3/4, LG. HX HD.
2	1	308046	Bushing	28	6	414887	GR.5 NYLOK HWY. Patch
3	2	308048	Bushing	29	1	414971	Capscrew-5/16-18 NC X 1 LG. HX. SOC.
4	1	316004	Cap-Bearing	30	1	416059	BUTTON HD. LOC-WEL
5	1	324163	Clutch-Jaw	31	1	416109	Screw-Poppet 1/2-20 NF HEADLESS SLOTTED
6	1	328010	Cover	32	1	416112	SeiscREW 3/8-16 NC X 1/2 LG. HX. SOC.HD. CUP PT.
7	2	330010	Shoe-Drum Brake	33	6	418163	SeiscREW 5/16-18 NC X 1/2 LG. SQ. HD CUP PT.
8	1	332139	Drum	34	2	442182	SeiscREW 5/16-18 NC X 3/4 LG. SQ HD. CUP PT
9	1	334016	Gear-R.H.	35	2	442183	Lockwasher-5/16 MED. SECT. C.P.
10	1	338278	Housing-Clutch	36	2	450017	Gasket-Bearing Cap
11	1	338269	Housing-Gear	37	3	456006	Gasket-Gear Housing Cover
12	1	342024	Key-Sq., End 3/16 x 3/16 x 1/2 LG.	38	1	456008	Key-Barth 1/2 X 1/2 X 2-3/4 LG.
13	1	342032	Key-Sq., End 3/16 x 3/16 x 1/2 LG.	39	2	462003	Fitting-Lube
14	2	342120	Key-Rd., End 1/2 x 1/2 x 1-11/16 LG.	40	1	468002	Fitting-Relief
15	1	356702	Shaft-Drum	41	1	468010	Quad-Ring
16	1	356902	Shaft-Shifter	42	1	468011	Reducer 3/8-18 NPT-1/8-27 NPT
17	1	358052	Handle-Shifter	43†	1	486079	Plug-Pipe 1/4-18 NPT SQ. HD.
18	1	362007	Spacer-Drum	44	1	462029	Plug-Pipe 3/8-18 NPT SQ. HD.
19	1	368183	Worm-RH	45	2	494005	Seal-Pilot
20	1	370003	Yoke	46	2	518026	O-ring
21	1	400003	Ball-Poppet	47	2	530094	Spring
22	1	402044	Bearing-Ball	48	1	*	Spring-Drum Brake
23	1	402107	Bearing-Thrust				Spring-Drum Brake
24	1	412005	Bushing				Spring-Drum brake
25	1	412006	Bushing				Washer-Thrust
26	6	414139	Capscrew 5/16-17 NC XI-1/4 LG. HX. HD., GR.5				Spacer-Drum Brake

*Motor not supplied by Ramsey
Motor

† If motor pilot height is 11", use P/N 486079
If motor pilot height is .25", use P/N 462029

**RAMSEY WINCH INDUSTRIAL WINCH
LIMITED WARRANTY**

1.1 Scope of Warranty Coverage. Upon the terms and subject to the conditions set forth in this limited warranty:

- (a) RAMSEY WINCH (referred to herein as “**RAMSEY WINCH**” or the “**Manufacturer**”) warrants to each initial end user customer (a “**Purchaser**”) of a new industrial winch together with any accessories manufactured and sold directly from RAMSEY WINCH (the “**Product**”) that the Product shall be free from defects in material and workmanship, under normal working and service conditions, for a period of eighteen (18) months from the date the Product is shipped from RAMSEY WINCH. (the “**Warranty Term**”). A Purchaser shall be eligible for an additional eighteen (18) months of coverage in addition to the Warranty Term (also referred to as the “**Standard (+) PLUS benefit**”) only if the Purchaser (i) complies with Section 1.2(a) and (ii) registers the Product during the Warranty Term at myproduct.ramseywinch.com.
- (b) Notwithstanding the foregoing, this warranty does not cover components damaged by accident, abuse, misuse, neglect, untrained operators, collision, overloading, modification, disassembly, rework, misapplication, improper installation, lack of lubrication or maintenance, or improper service. This warranty does not cover the paint or material finish, rope (wire or synthetic), removal or reinstallation of the winch, or normal wear and tear and loss of functionality due to aging of the Product (which may include but is not limited to bearings, bushings, seals, O-rings, gaskets, brake material, motor brushes, electrical cables and more).

1.2 Eligibility of Warranty Coverage.

- (a) A Purchaser shall be eligible for warranty coverage under this Limited Warranty during the Warranty Term only if:
 - (i) Prior to placing a Product in service, and throughout use of the Product during the Warranty Term, the Purchaser provides (or causes to be provided) proper storage such that foreign objects (e.g. rain or debris) cannot enter any Product through entry ports which are normally closed during operation.; and
 - (ii) The Purchaser maintains, or causes to be maintained, the Product according to commercially reasonable standards and utilizes the Product for the purposes for which it was created; and
 - (iii) No repairs or alterations have been made by any party other than RAMSEY WINCH, including Purchaser, unless otherwise authorized in writing by RAMSEY WINCH.

1.3 Transferability of Warranty.

- (a) This warranty is transferable only from the Purchaser to the first subsequent transferee (the “**Transferee**”) of the Product from Purchaser upon (i) written notification to RAMSEY WINCH and (ii) registration of the transfer, both within 30 days of such Product transfer.
- (b) Upon satisfaction of transfer requirements set forth in Section 1.3(a), the Transferee shall succeed to all the rights and obligations of the Purchaser set forth in this Limited Warranty.

1.4 Certain Limitations on Scope of Warranty Service.

- (a) Any obligation of RAMSEY WINCH under this warranty, statutory or otherwise, is limited to the repair of the Product, at its factory or Authorized Service Centers. Notwithstanding the foregoing, if field service or repair is performed by RAMSEY WINCH at the request of the Purchaser and no defect is found with material or workmanship of the Product, the Purchaser shall compensate RAMSEY WINCH for its time and expenses within thirty (30) days of delivery of an invoice relating to the same. If repair is determined by RAMSEY WINCH in its sole, absolute and uncontrolled discretion to be impossible or impractical, then RAMSEY WINCH may satisfy this warranty by replacing the Product. RAMSEY WINCH will not provide any cash payment or credits for defective materials or workmanship.

- (b) Purchaser shall be responsible for any and all freight charges for any Product receiving warranty service under this limited warranty. Any travel time, transportation charges, freight charges, or similar costs incurred by RAMSEY WINCH in connection with the replacement or repair of defective parts, shall, be the responsibility of the Purchaser. If applicable, RAMSEY WINCH shall invoice Purchaser for the total amount of such charges within sixty (60) days of fulfilling its duties under this warranty, payable within thirty (30) days of delivery of such invoice. In no event shall RAMSEY WINCH be liable for bills for service, labor or other expenses that have been incurred by the Purchaser without approval or prior authorization by RAMSEY WINCH for inspection, maintenance, or repair of the Product.
- (c) If a Product is found to be operable upon inspection, the Product, at Purchaser's election, may be either (1) returned to the Purchaser with a service charge from RAMSEY WINCH for inspection, cleaning, and routine replacement of all rubber components and any other parts that show wear; or (2) RAMSEY WINCH can dispose of the product safely.

1.5 **Limitations of Liability.** RAMSEY WINCH shall in no event be liable for punitive, special or consequential damages relating to the Product or this Warranty. RAMSEY WINCH makes no warranty in respect to third-party accessories, upgrades, or additions to the Product.

1.6 **Improving Product.** RAMSEY WINCH reserves the right to improve the Product through changes in design or materials as it may deem desirable or necessary without being obligated to incorporate, upgrade, or otherwise modify previously manufactured products.

1.7 **Limitations of Warranty.**

- (a) THE WARRANTY SET FORTH ABOVE IS THE ONLY EXPRESS WARRANTY. RAMSEY WINCH HEREBY DISCLAIMS AND EXCLUDES ANY OTHER EXPRESS, IMPLIED, OR STATUTORY WARRANTIES, ARISING BY OPERATION OF LAW, COURSE OF DEALING, COURSE OF PERFORMANCE, USAGE, OF TRADE, OR OTHERWISE, INCLUDING, WITHOUT LIMITATION, ANY WARRANTIES OF MERCHANTABILITY, FITNESS FOR A PARTICULAR PURPOSE, AND INTELLECTUAL PROPERTY RIGHTS OF A THIRD PARTY.
- (b) ANY IMPLIED WARRANTY WHICH BY LAW MAY NOT BE EXCLUDED IS LIMITED IN DURATION TO ONE (1) YEAR FROM THE DATE OF ORIGINAL RETAIL PURCHASE OF THE PRODUCT.
- (c) This warranty gives you specific legal rights, and you may also have other rights which vary from jurisdiction to jurisdiction.
- (d) This warranty is valid only in the U.S.A. and Canada. For warranty outside the U.S.A. and Canada contact your nearest Ramsey Winch Distributor.

1.8 **No Modifications to Warranty.** No RAMSEY WINCH dealer, distributor, agent or employee is authorized to make any modification, extension or addition to this warranty.

1.9 **How to Apply for Warranty Coverage.**

All claims are handled by contacting your nearest Ramsey Winch Distributor. For questions, please contact customer support: rwcustomersupport@ramseyindustries.com.

Visit [Dealer Locator - Ramsey Winch](#) for Ramsey Winch Distributor locations and contact information.

Additional warranty, service support, product information, and parts information can be found on www.ramseywinch.com.

NOTES

NOTES

