

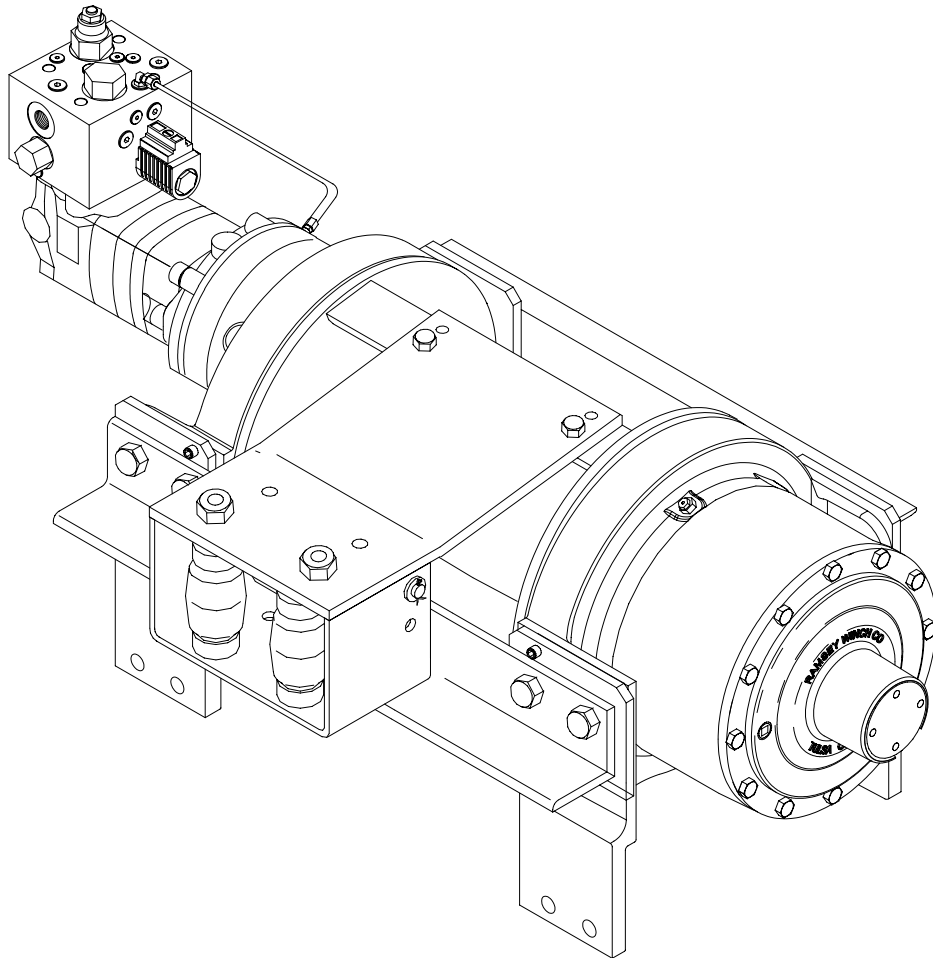

# OPERATING, SERVICE AND MAINTENANCE MANUAL



## MODEL RPH-45,000 INDUSTRIAL PLANETARY WINCH WITH AIR TENSIONER AND 2 SPEED MOTOR



**CAUTION:** READ AND UNDERSTAND THIS MANUAL BEFORE INSTALLATION AND OPERATION OF WINCH. SEE WARNINGS!

## TABLE OF CONTENTS

INTRODUCTION.....	1
WARRANTY INFORMATION .....	1
SPECIFICATIONS .....	1
WARNINGS .....	1
WINCH MOUNTING .....	2
CABLE INSTALLATION.....	2
HYDRAULIC SYSTEM REQUIREMENTS .....	2
PERFORMANCE CHARTS .....	3
CLUTCH OPERATION .....	3
WINCH OPERATION.....	3
MAINTENANCE .....	4
TROUBLE SHOOTING GUIDE .....	4
INSTRUCTIONS FOR OVERHAUL.....	5-12
MOUNTING CONFIGURATIONS.....	12
DIMENSIONAL DRAWING.....	14
PARTS LIST AND PART DRAWING.....	15-17
LIMITED WARRANTY .....	Back cover

# RAMSEY HYDRAULIC PLANETARY WINCH MODEL RPH 45,000

## PLEASE READ THIS MANUAL CAREFULLY

This manual contains useful ideas in obtaining the most efficient operation from your Ramsey Winch, and safety procedures one needs to know before operating a Ramsey Winch. Do not operate this winch until you have carefully read and understand the "WARNINGS" and "OPERATION" sections of this manual.

## WARRANTY INFORMATION

Ramsey Winches are designed and built to exacting specifications. Great care and skill go into every winch we make. If the need should arise, warranty procedure is outlined on the back of your self-addressed postage paid warranty card. Please read and fill out the enclosed warranty card and send it to Ramsey Winch Company. If you have any problems with our winch, please follow instructions for prompt service on all warranty claims. Refer to back page for limited warranty.

## SPECIFICATIONS\* (LOW SPEED MODE)

Rated Line Pull (lbs.).....		45,000					
(Kgs.).....		20,380					
Gear Reduction.....		51.35:1					
Weight (without cable).....		689 lb. (313 Kgs.)					
LAYER OF CABLE		1	2	3	4	5	6**
*Rated line pull per layer	Lbs. Kg.	45,000 20,380	37,700 17,100	32,400 14,690	28,500 12,920	25,300 11,460	22,900 10,380
*Cable capacity	Ft. M.	35 10	75 22	125 38	180 54	245 74	310 94
*Line speed (at 25 GPM)	FPM MPM	23 7.0	27 8.2	32 9.8	36 11.0	40 12.2	45 13.7
* These specifications are based on recommended wire rope of .75 inch dia. extra improved plow steel or equivalent							
** Last layer does not conform to SAE J706							

**NOTE:** The rated line pulls shown are for the winch only. Consult the wire rope manufacturer for wire rope ratings.

## WARNINGS:

**CLUTCH MUST BE TOTALLY ENGAGED BEFORE STARTING THE WINCHING OPERATION.**

**DO NOT START WINCH MOTOR BEFORE ENGAGING CLUTCH.**

**DO NOT DISENGAGE CLUTCH UNDER LOAD.**

**STAY OUT FROM UNDER AND AWAY FROM RAISED LOADS.**

**STAND CLEAR OF CABLE WHILE PULLING. DO NOT TRY TO GUIDE CABLE.**

**DO NOT EXCEED MAXIMUM LINE PULL RATINGS SHOWN IN TABLE.**

**DO NOT USE WINCH TO LIFT, SUPPORT, OR OTHERWISE TRANSPORT PEOPLE.**

**A MINIMUM OF 5 WRAPS OF CABLE AROUND THE DRUM BARREL IS NECESSARY TO HOLD THE LOAD. CABLE ANCHOR IS NOT DESIGNED TO HOLD LOAD.**

## WINCH MOUNTING

Use (8) 3/4" diameter grade 5 or better bolts to attach winch to the wrecker.

Before operating the winch for the first time, remove the cover from the breather vent at the back of the air cylinder and the relief fitting on top of the clutch housing.

## CABLE INSTALLATION

1. Unwind cable by rolling it out along the ground to prevent kinking. Securely wrap end of wire rope, opposite hook, with plastic or similar tape to prevent fraying.
2. Insert the end of cable, opposite hook end, into the hole in drum barrel. Secure cable to drum barrel, using setscrew furnished with winch. **TIGHTEN SETSCREW SECURELY.**
3. Carefully run the winch in the "reel-in" direction. Keeping tension on end of cable, spool all the cable onto the cable drum, taking care to form neatly wrapped layers.

## HYDRAULIC SYSTEM REQUIREMENTS

Refer to the performance charts to properly match your hydraulic system to RPH-45000 winch performance. The charts consist of:

- (1) Line pull (lb.) first layer vs. working pressure (PSI) and (2) Line speed (FPM) first layer vs. flow (GPM). Performance is based on a motor displacement of 9.6 cubic inches with 25 GPM maximum flow rate. See page 13 for motor port size.

## TYPICAL LAYOUT

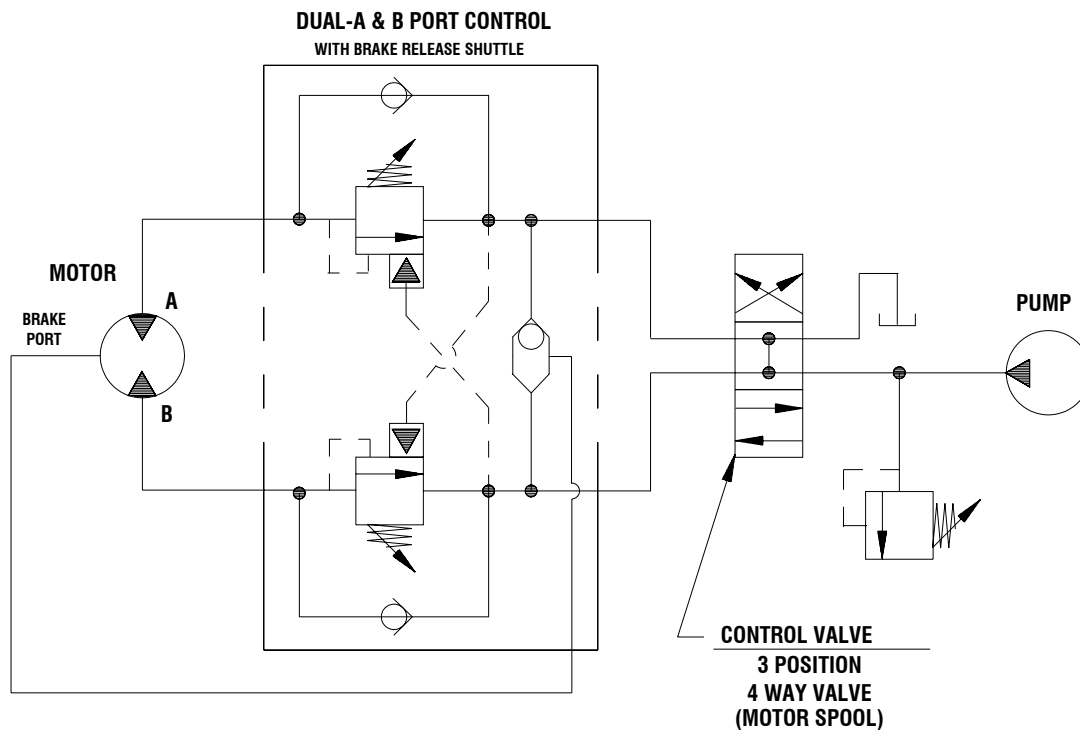

## PERFORMANCE CHARTS

(BASED ON 9.6 CU. IN./REV MOTOR)

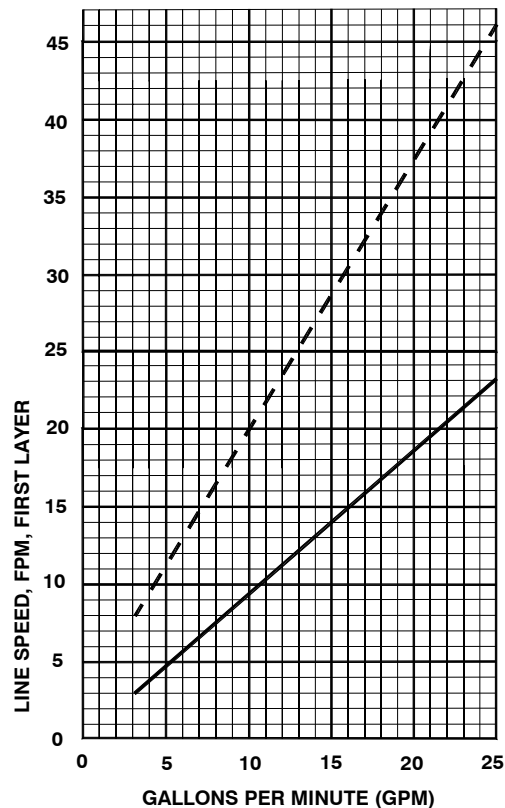
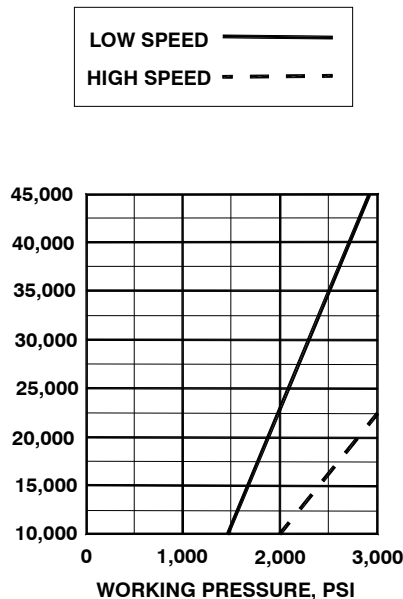

## CLUTCH OPERATION

### To engage clutch:

1. Move the clutch control valve to the "clutch engaged" position.
2. Anytime the temperature is below freezing, run the motor in the "cable out" direction only until the drum starts to turn. In extreme cold temperatures (below 0° F/-18° C), pull out on the cable by hand only until the drum starts to turn.
3. Wait at least 3 seconds for the clutch to fully engage, after which the winch is ready to winch in the cable.

**WARNING: Do not attempt to engage the clutch by first running the winch motor and then moving the clutch control valve to the "clutch-engaged" position while the motor is running. Do not start picking up the load at the same time the clutch is being engaged.**

### To disengage clutch:

1. Run the winch in the "cable out" direction until the load is off the cable.
2. Move the clutch control valve to the "clutch-disengaged" position.
3. The cable may now be pulled off by hand.

## WINCH OPERATION

The best way to get acquainted with how your winch operates is to make test runs before you use it. Plan your test in advance. Remember, you hear your winch, as well as see it operate. Learn to recognize the sounds of a light steady pull, a heavy pull, and sounds caused by load jerking or shifting. Gain confidence in operating your winch and its use will become second nature with you.

The uneven spooling of cable, while pulling a load, is not a problem, unless there is a cable pileup on one end of drum. If this happens, reverse the winch to relieve the load and move your anchor point further to the center of the vehicle. After the job is done you can unspool and rewind for a neat lay of the cable.

## MAINTENANCE

Adhering to the following maintenance schedule will keep your winch in top condition and performing as it should with a minimum of repair.

### A. WEEKLY

1. Check the oil level and maintain it to the oil level plug. If oil is leaking out, determine location and repair.
2. Check the pressure relief plug in top of the gear housing. Be sure that it is not plugged.
3. Lubricate cable with light oil.

### B. MONTHLY

1. Check the winch mounting bolts. If any are missing, replace them and securely tighten any that are loose. Use grade 5 or better bolts.
2. Inspect the cable. If the cable has become frayed with broken strands, replace immediately.

### C. ANNUALLY

1. Drain the oil from the winch annually or more often if winch is used frequently.
2. Fill the winch to the oil level plug with clean kerosene. Run the winch a few seconds with no load in the reel in direction. Drain the kerosene from the winch.
3. Refill the winch to the oil level plug with all-purpose SAE 80W-140 gear oil.
4. Inspect frame and surrounding structure for cracks or deformation.

## TROUBLESHOOTING GUIDE

CONDITIONS	POSSIBLE CAUSE	CORRECTION
OIL LEAKS FROM WINCH	<ol style="list-style-type: none"><li>1. Seals damaged or worn.</li><li>2. Too much oil.</li><li>3. Damaged gaskets.</li></ol>	<ol style="list-style-type: none"><li>1. Replace seal.</li><li>2. Drain excess oil. Refer to OPERATION.</li><li>3. Replace gaskets.</li></ol>
WINCH RUNS TOO SLOW	<ol style="list-style-type: none"><li>1. Low flow rate</li><li>2. Hydraulic motor worn out.</li></ol>	<ol style="list-style-type: none"><li>1. Check flow rate. Refer to HYDRAULIC SYSTEMS performance chart page 2.</li><li>2. Replace motor.</li></ol>
CABLE DRUM WILL NOT FREESPOOL	<ol style="list-style-type: none"><li>1. Clutch not disengaged</li></ol>	<ol style="list-style-type: none"><li>1. Check air pressure to clutch cylinder 100 PSI minimum required-Refer to page 13 for port location.</li></ol>
BRAKE WILL NOT RELEASE	<ol style="list-style-type: none"><li>1. Brake line disconnected or blocked.</li></ol>	<ol style="list-style-type: none"><li>1. Check brake function. Refer to page 12.</li></ol>

# INSTRUCTIONS FOR OVERHAUL

## DIS-ASSEMBLY

1. Drain oil from gear housing #10 by removing pipe cap #44 from pipe nipple in end bearing. Remove reducer #43 and relief fitting #39. If new air cylinder is required, remove air cylinder #34 from cover by removing (4) capscrews #23.

Remove washer #25, nut #26, setscrew #21, and insert #31 from end of air cylinder rod. Apply Loctite to threads of nut #26 and thread onto setscrew #21 to 3/8" from drive end, as shown below. Apply Loctite to threads of setscrew and thread insert #31 over end of setscrew and against nut. Use setscrew and nut to thread insert #31 into end of air cylinder rod. Tighten nut against cylinder rod, keeping 3/8" distance from drive end of setscrew to nut. If breather vent #39 is damaged, remove and replace.

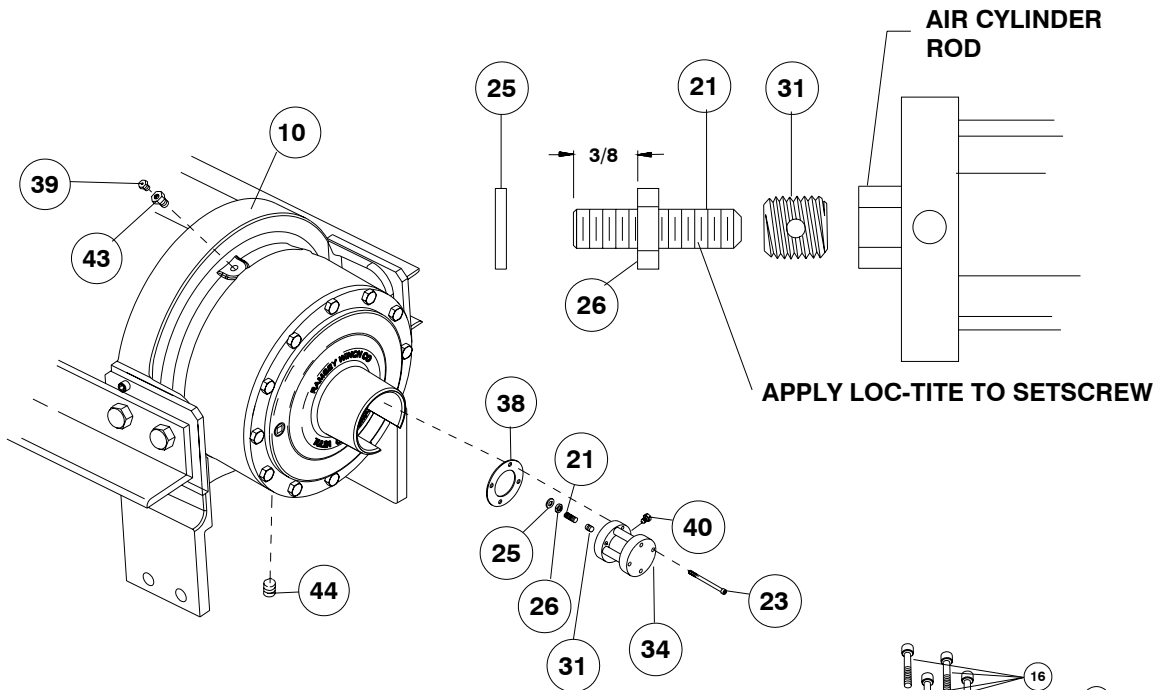

2. Disconnect tube #48 from elbow #32 on valve #49 and fitting #33 on bottom of brake #35. Remove motor #41 and gasket #35a by removing (2) capscrews #17. Remove valve #49, if needed, from motor by loosening (4) capscrews #16.

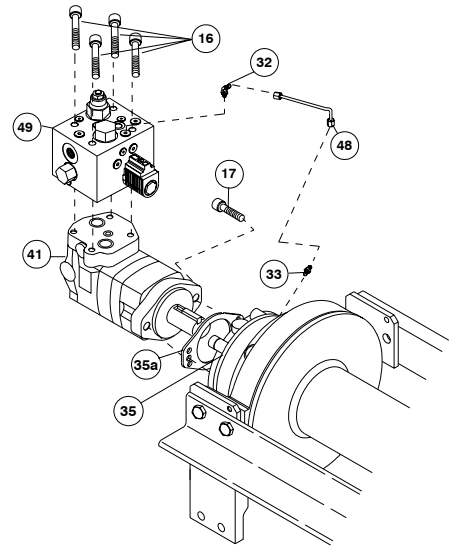

- Remove brake assembly screws #52 from brake #35a to access (2) mounting screws #20 attaching brake to end bearing #9. **Caution: Brake is spring loaded by clutch spring and must be restrained against end bearing as mounting screws are removed.** Remove coupling #8 and gasket #35e from end bearing. Take note of mounting configuration for proper mounting of parts during re-assembly.

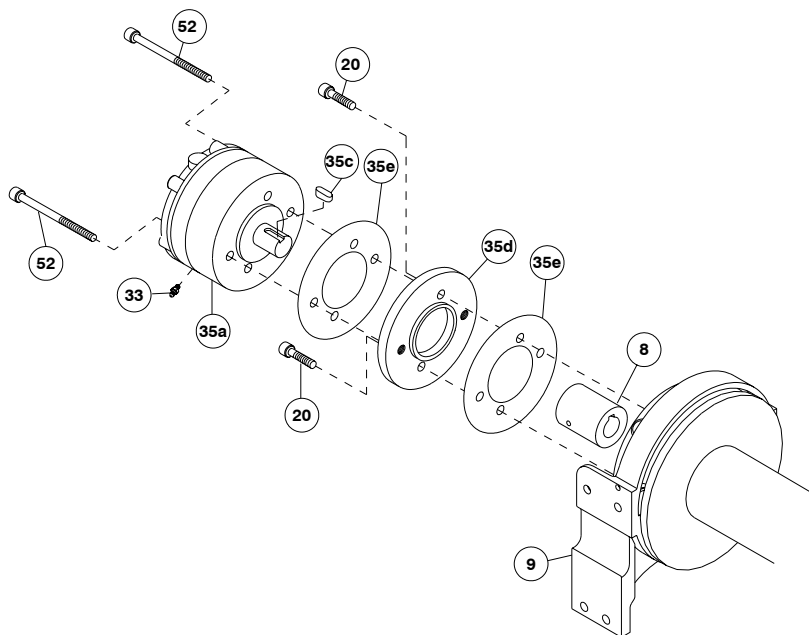

- Remove winch from tie bars #2 and #3 by removing (8) capscrews #19, (8) lockwashers #24, and (4) shoulder bolts #28. Pull motor end bearing #9 from drum assembly #1.

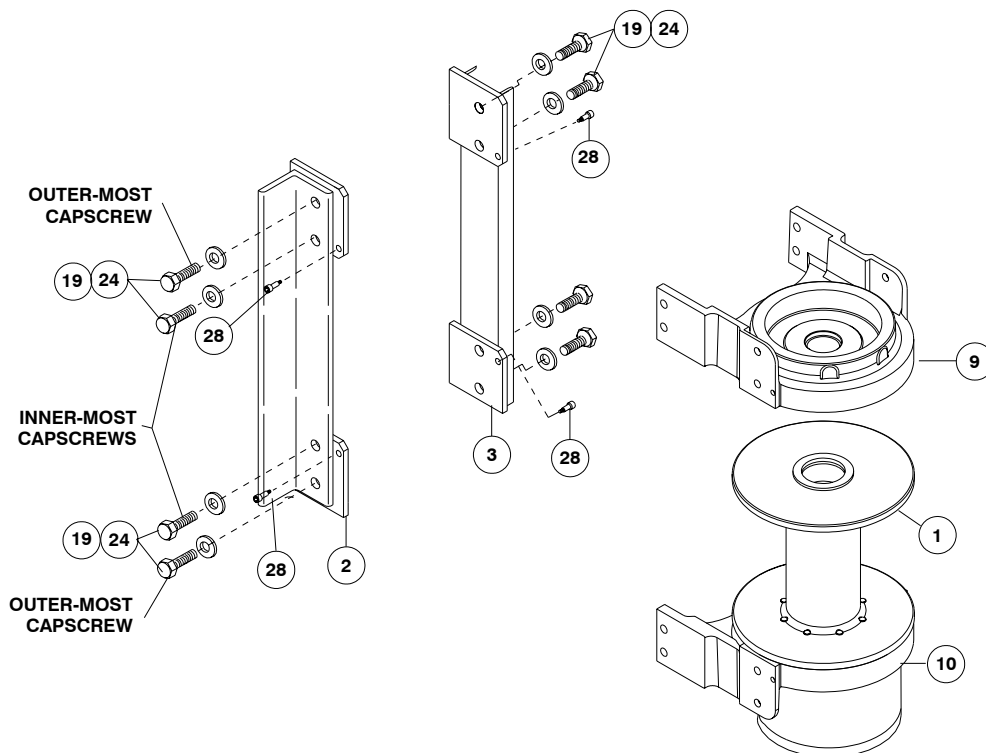



5. Pull drum assembly #1 upward from end bearing #10. Remove quad-rings #42 from grooves in drum bushings. Remove input shaft #12, clutch springs #46 & #47 and washers #27 & #29 from end bearing. Examine splined ends of input shaft for signs of wear, replace if damaged.

Examine drum assembly #1 for signs of wear. If splines inside of drum driver (332148) are damaged, drum driver must be replaced. Remove drum driver by unscrewing (8) capscrews (414978). If bushings show signs of wear, replace by pressing old bushings from drum and removing o-rings from grooves in drum and drum driver. Place well-oiled o-rings (462043) into grooves in drum and drum driver. Press new bushing (412078) into end of drum opposite drum driver and press bushing (412079) into drum driver until flange of bushings are flush against drum and driver.

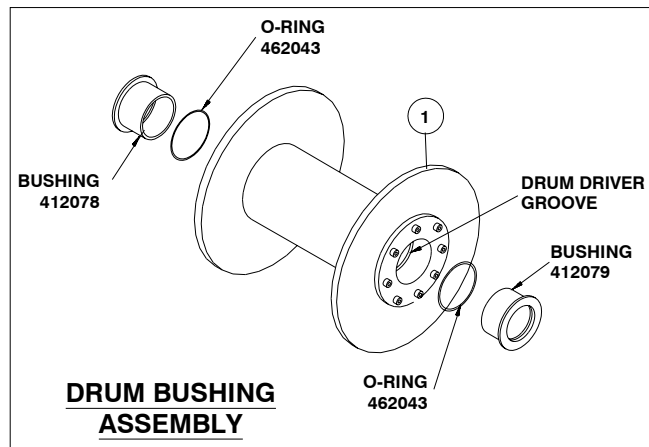
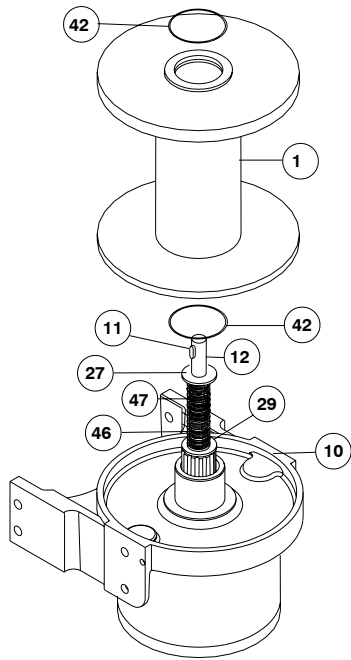

6. Remove output coupling #6 and coupling shaft #7 from end bearing #10. Examine bearings #14 pressed in output coupling for signs of wear. Replace bearings, if necessary, by pressing old bearings from coupling and press new bearings into each end of output coupling. Place coupling shaft into bearings.

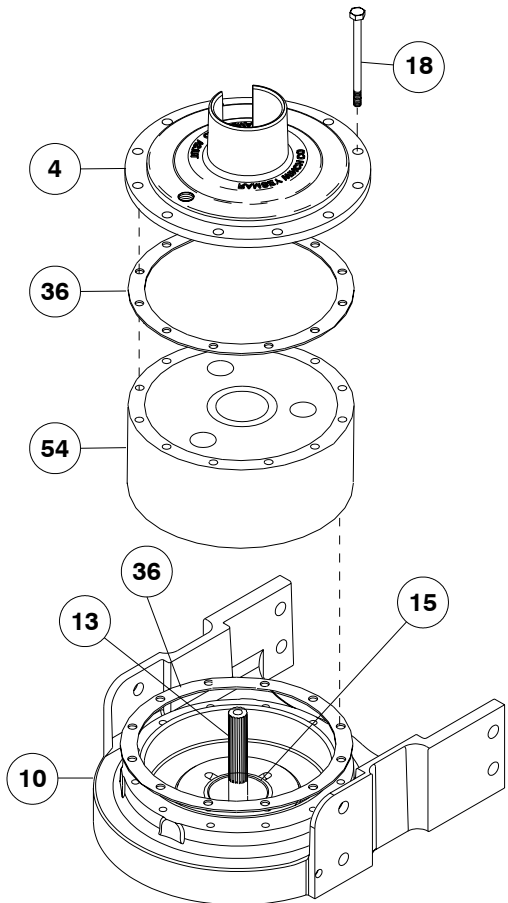
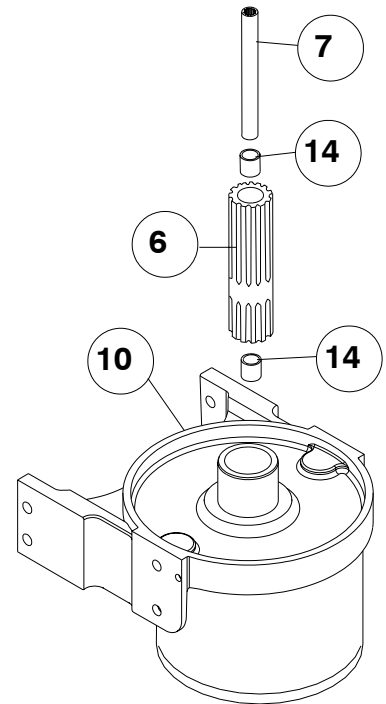

7. Remove (12) cap screws #18 to pull gear-housing cover and gasket from ring gear. Remove input thrust washer, sun gear and carrier assemblies from inside of ring gear. Remove ring gear #4 and gasket #36 from end bearing #10. Examine shifter shaft #13 for signs of wear, replace if necessary. Examine bushing #15 for signs of wear. Replace bushing, if necessary, by pressing old bushing from housing and pressing new bushing into place.

## RE-ASSEMBLY

8. **NOTE: DETERMINE MOUNTING CONFIGURATION OF WINCH (R.H. or L.H. MOUNTED) BEFORE ATTACHING UPRIGHT FRAME TO WINCH, TO ASSURE PARTS ARE MOUNTED TO PROPER SIDE, REFER TO WINCH MOUNTING CONFIGURATIONS ON PAGE 12.**

Seat well-oiled quad-ring #42 into groove of bushing in each end of drum assembly #1. Carefully set drum assembly down over motor end bearing #9. Lift gear-housing end bearing #10 and set into place on drum assembly. Attach tie bars #2 and #3 using (8) capscrews #19 and lockwashers #24. Install (4) shoulder bolts #28 and hand tighten. Tighten (4) innermost capscrews securely; check rotation of cable drum. Tighten (4) outer-most capscrews securely, check rotation of cable drum. Torque capscrews, in above innermost then outer-most pattern, to 430 ft.-lbs. each. Torque shoulder bolts to 30 ft.-lbs. each. Check rotation of cable drum assembly. It must rotate freely with no tight spots.

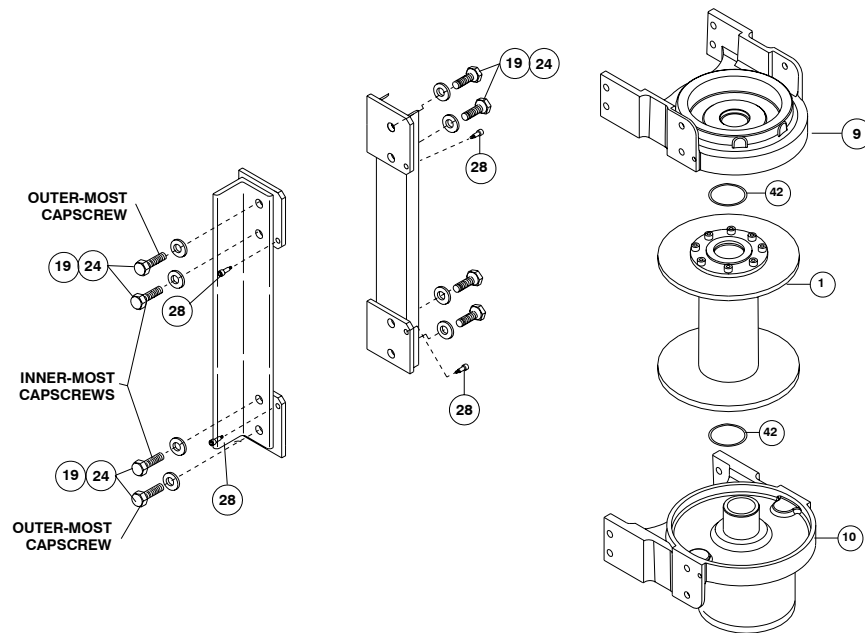

9. Place end (with longest splines) of output coupling assembly #6 through end bearing bushing #15 and mesh coupling spline with spline inside of drum. Slide clutch spacer #30 over end and against shoulder of shifter shaft #13. Place shifter shaft through washer #29 and into shaft coupling #7, meshing splines of shifter shaft with splines in shaft coupling.

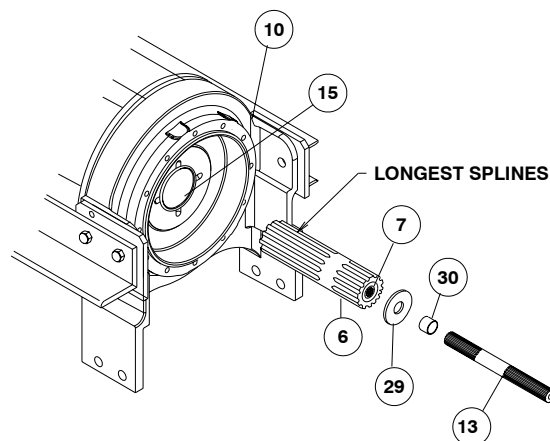

10. Set gasket #36 into place on gear housing end bearing #10. Place ring gear #54 onto end bearing, aligning holes in ring gear with holes in gasket and gear housing end bearing. Use (2) capscrews to temporarily secure ring gear to end bearing. Place (2) gear carrier assemblies into ring gear meshing carrier gears with ring gear. Slide input sun gear over shifter shaft #13 and mesh with teeth of input carrier. Apply grease to input thrust washer and place into slots of gearbox cover. Place gasket #36 into position on gearbox cover with sealer. Remove (2) temporary capscrews and attach cover #4 and gasket #36 to ring gear end bearing. Use (12) capscrews #18 to secure gearbox to gear housing end bearing. Torque capscrews to 87 ft.-lbs. each, in a criss-cross pattern.

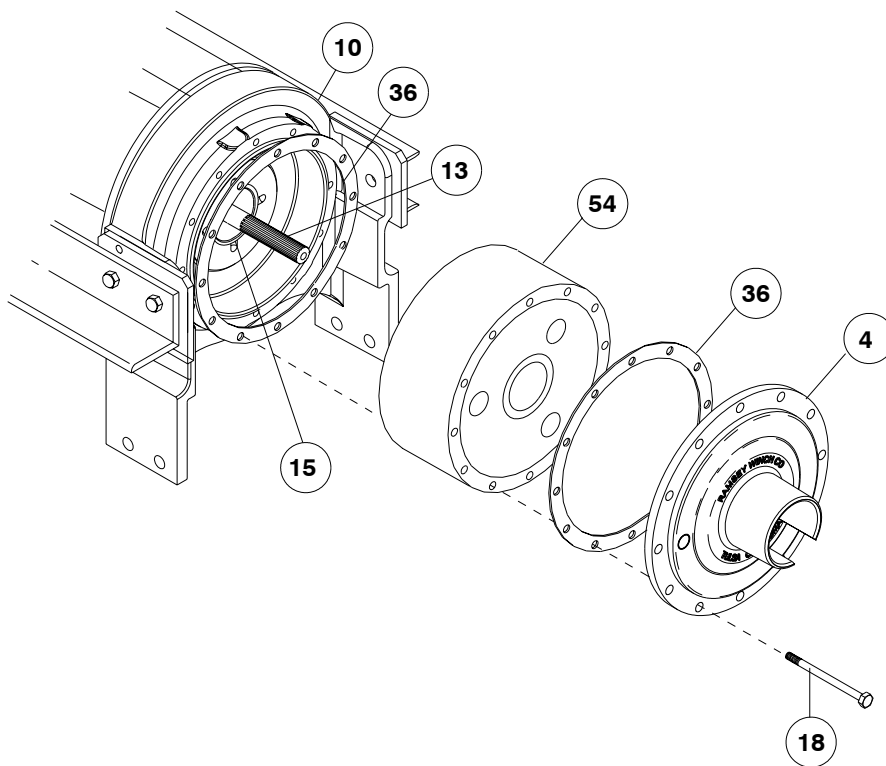

11. Pull rod from air cylinder as far as possible. Slide washer #25 over setscrew #21 and against nut attached to air cylinder rod. Place setscrew into hole of shifter shaft #13 and attach air cylinder to gearbox cover using (4) capscrews #23. Apply Loctite PST thread sealer to threads of capscrews. Torque capscrews to 5 ft.-lbs. each, in criss-cross pattern.

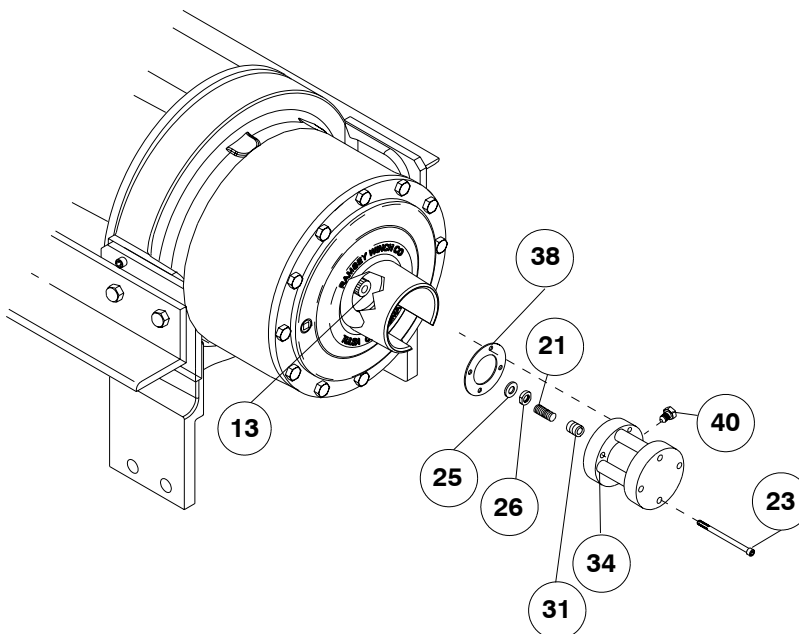

12. Gently tap key #11 into keyway of input shaft #12. Liberally apply grease to shoulder of input shaft. Place 1-3/4 OD washer #27 over end of shaft and against shoulder of shaft. Place spring #46 inside of spring #47 and place both springs over shaft and against washer #27. Slide 2-3/8 OD clutch washer #29 over splined end of shaft and against springs. Use grease to hold springs and washers in place on shaft. Place splined end of shaft through drum and into output coupling #6. Mesh spline of input shaft with internal spline of coupling shaft inside of drum.

With pin #45 installed in coupling #8, align keyway of coupling with key on end of input shaft. Slide coupling over end of shaft #12. Place gasket #35e into position on motor mounting surface of end bearing #9. Use (2) screws #20 to attach brake adapter plate #35d to motor end bearing. Torque capscrews to 85 ft.-lbs. each. Place second gasket #35e on adapter plate. Insert brake shaft with key into coupling. Use (2) screws #52 to attach brake assembly to adapter plate. Torque capscrews to 97 ft.-lbs. each.

**Note:** Care must be taken to assure cover and brake module are seated properly prior to installing 1/2-13NC assembly bolts. Damage will occur to rotor stack or shaft snap ring if not properly installed.

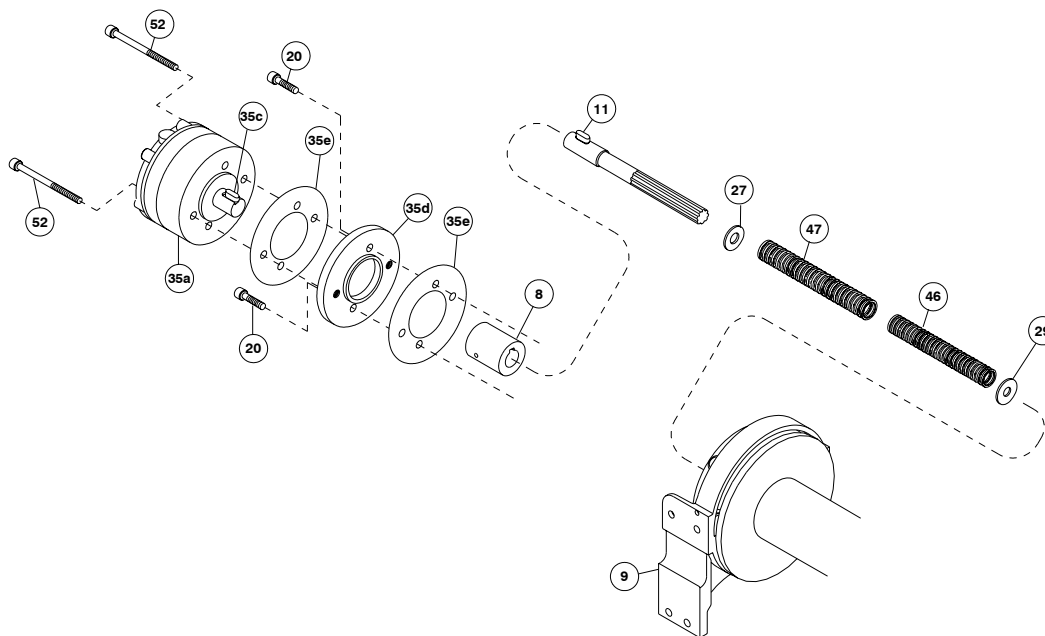

13. Attach motor #41 with well-oiled gasket #35a to brake #35. Use (2) capscrews #17 and torque to 74 ft.-lbs. each. Securely connect tube #48 to elbow #32, in top of valve #49, and fitting #33 in top of brake #35.

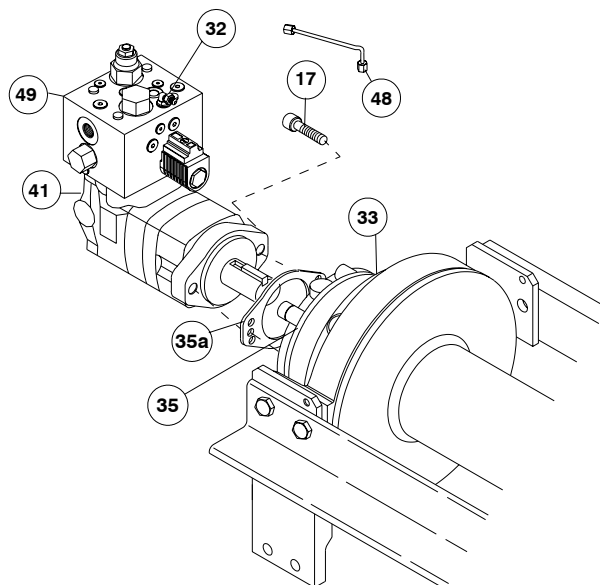

14. Apply Permatex to thread of plug #44. Thread plug into tapped hole in bottom of gear housing end bearing #10. Pour approximately 4.75 pints of SAE 80W-140 oil into end bearing. Check oil level by removing oil plug noted below. Insert relief fitting #39 and thread reducer #43 into end bearing at oil fill hole. Be sure breather vent #39 and relief fitting #43 are not damaged and in good operating condition. Replace if necessary.

Install winch and connect pressure lines. Apply at least 230 PSI pressure to release brake and verify that brake releases, by observing that the winch drum rotates.

15. Check proper operation of clutch by applying air pressure to clutch air cylinder to disengage clutch. Verify that winch freespools. Re-engage clutch. A loud noise should be heard when the clutch engages. Winch drum should not freespool.

16. Operate winch forward and reverse to verify that drum rotates.

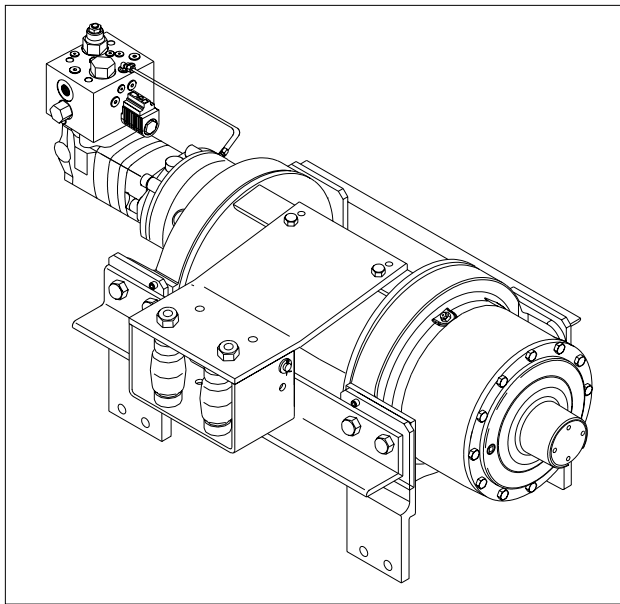
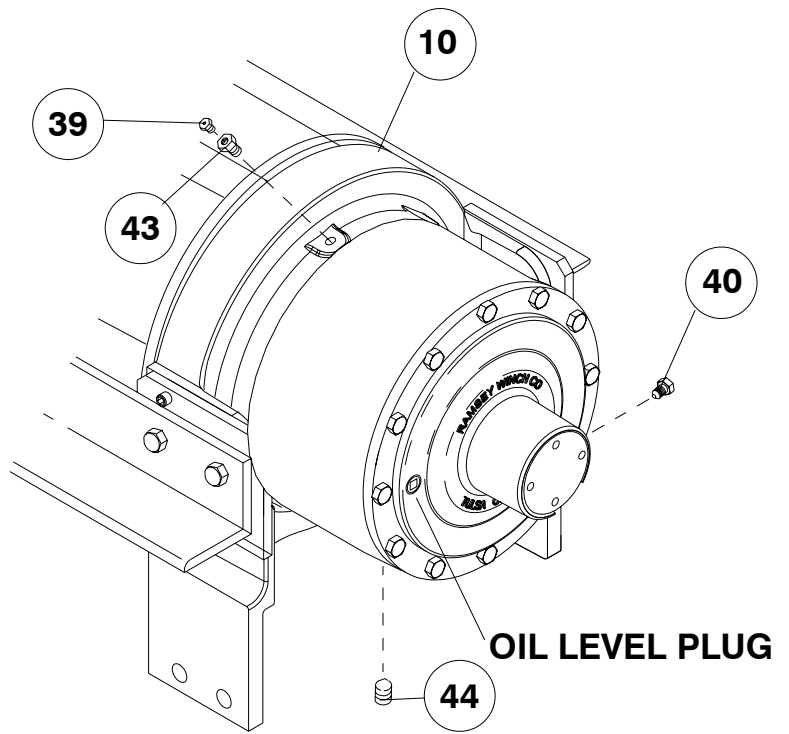

**R. H. MOUNTING  
CONFIGURATION**

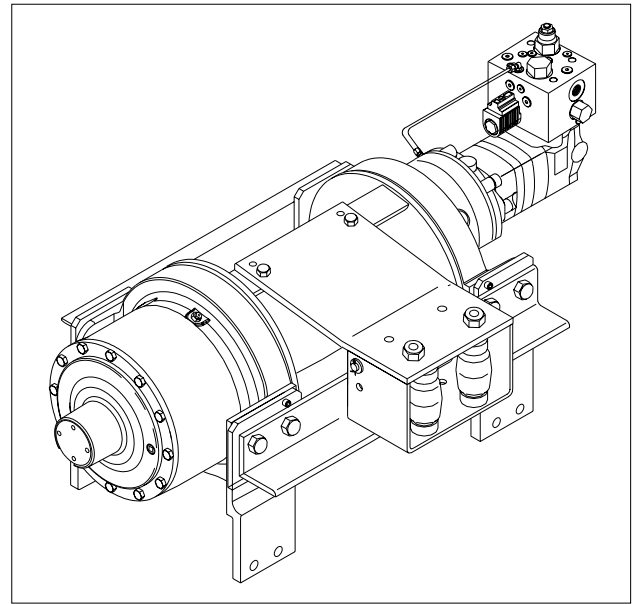

**L. H. MOUNTING  
CONFIGURATION**

## **WINCH MOUNTING CONFIGURATIONS**

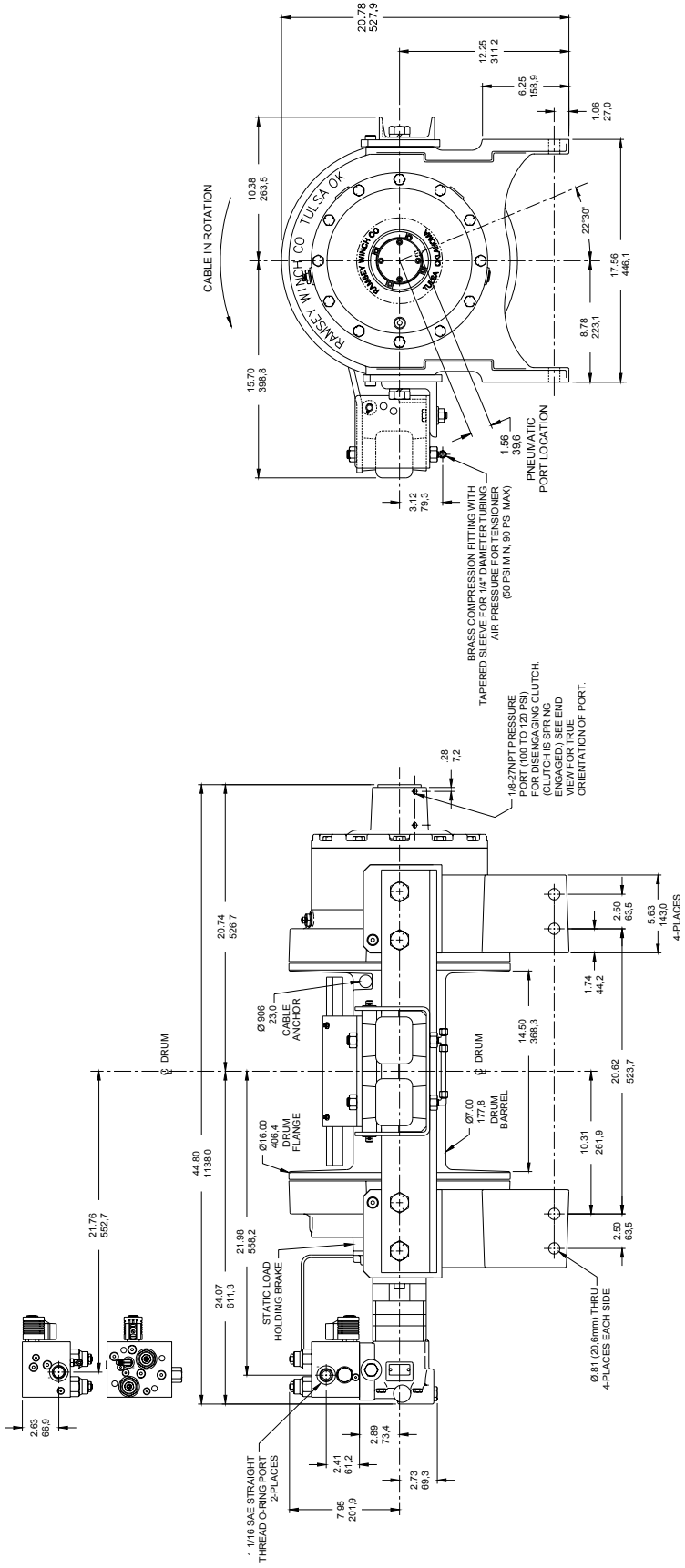

**RP45000**  
 STANDARD DRUM  
 R.H. MOUNTING CONFIGURATION  
 2-SPEED STANDARD MOTOR  
 OVER WOUND AIR TENSIONER  
 "B" ROTATION SHOWN

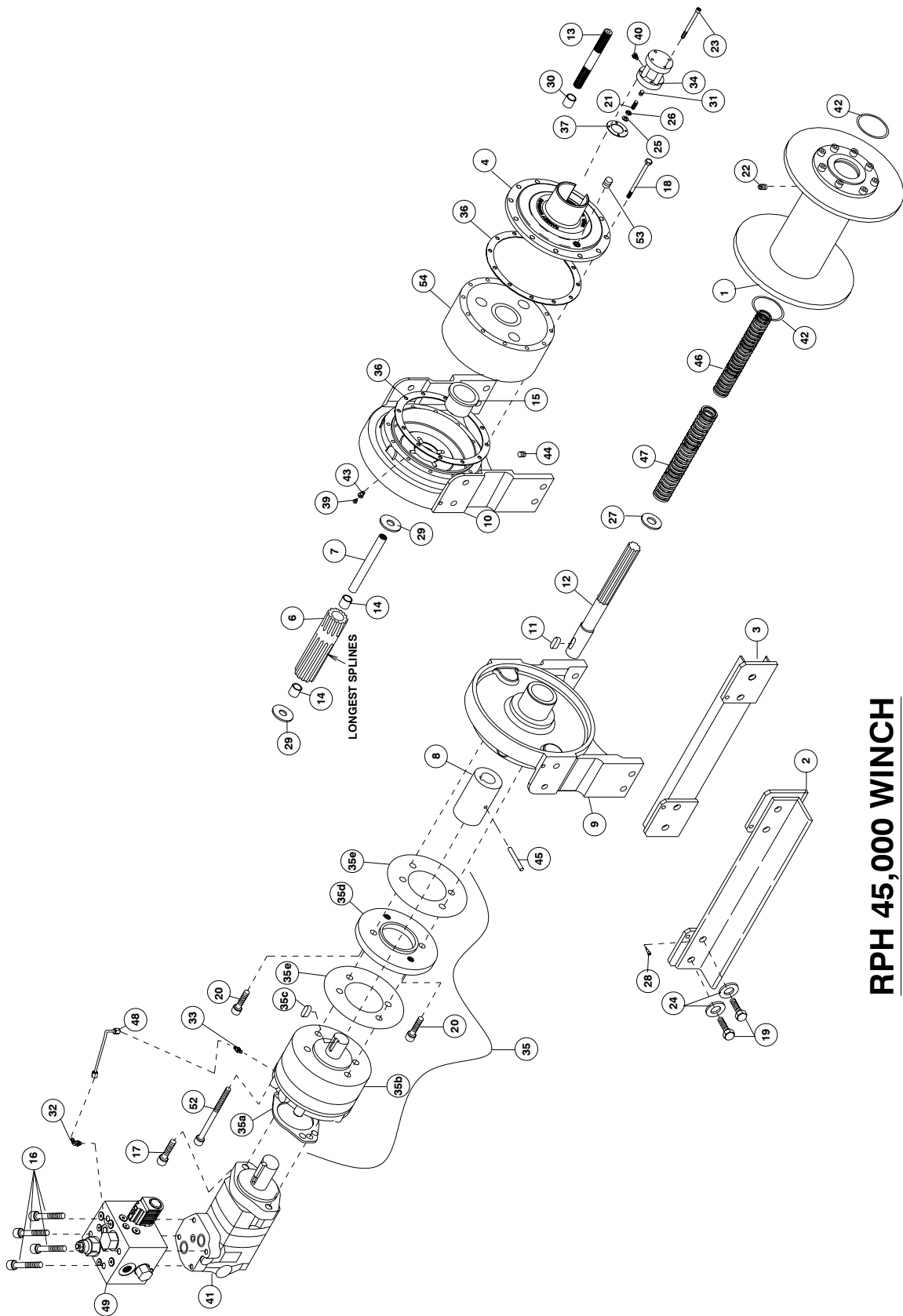

**RPH 45,000 WINCH**



**PARTS LIST – RPH 45000**

ITEM	QTY.	PART NO.	DESCRIPTION	ITEM	QTY.	PART NO.	DESCRIPTION
1	1	234156	DRUM ASSEMBLY	32	1	432018	FITTING – HYD. 7/16-20 90° ELBOW
2	1	243037	TIE BAR	33	1	432023	FITTING – 7/16-20 STRAIGHT
3	1	243038	TIE BAR	34	1	433013	AIR CYLINDER
4	1	328158	GEAR BOX COVER	35	1	438037	BRAKE ASSEMBLY
5	1	299704	TENSIONER ASSEMBLY (SEE FOLLOWING PAGE)	a	1		BRAKE
6	1	324282	COUPLING – OUTPUT	b	1		MOTOR END GASKET
7	1	324283	COUPLING – SHAFT	c	1		KEY
8	1	324284	COUPLING – BRAKE	d	1		ADAPTER PLATE
9	1	338340	END BEARING – MOTOR	e	2		ADAPTER PLATE GASKET
10	1	338341	END BEARING – GEAR	36	2	442210	GASKET – GEAR BOX
11	1	342081	KEY – RD. END	37			NOT USED
12	1	357492	SHAFT – INPUT	38	1	442217	GASKET – AIR CYLINDER
13	1	358064	SHAFT – SHIFTER	39	1	456008	RELIEF FITTING
14	2	402117	BEARING	40	1	456038	BREATHER VENT
15	1	412086	BUSHING – THRUST	41	1	458101	MOTOR – HYDRAULIC
16	4	414400	CAPSCREW 3/8-24NF X 4 HX HD	42	2	462040	QUAD. RING
17	2	414948	CAPSCREW 1/2-13NC X 1-1/4 SOC HD	43	1	468004	REDUCER
18	12	414557	CAPSCREW 1/2-13NC X 6 LG. HX HD GR 5	44	1	468019	PIPE PLUG
19	8	414784	CAPSCREW 7/8-9NC X 2 LG. HX HD GR 5	45	1	470075	PIN
20	2	414947	CAPSCREW 1/2-13 NC X 1LG. SOC HD	46	1	494106	SPRING
21	1	416051	SETSCREW 5/16-24NF X 1 LG. SOC HD	47	1	494114	SPRING – CLUTCH, OUTER
22	1	416072	SETSCREW 1/2-13NC X 3/4 LG. HX SOC HD	48	1	509122	TUBE ASSEMBLY
23	4	416211	CAPSCREW #10-24 NC X 3.25 HX SOC HD	49	1	516024	VALVE – CONTROL (INCLUDES ITEMS 50 AND 51)
24	8	418261	LOCKWASHER 7/8 MED. SECT	50*	1	516034	SOLENOID ASSEMBLY W/COIL – CC VALVE
25	1	418429	WASHER – THRUST		1	516037	SOLENOIDE ASSEMBLY W/COIL – DAMON VALVE
26	1	418430	NUT – 5/16-24NF X 1/8 THK, LOCK	51*	1	516038	COIL – SOLENOID VALVE – CC VALVE
27	1	418440	WASHER – SPRING, 1-3/4 OD		1	516039	COIL – SOLENOID VALVE – DAMON
28	4	418453	SHOULDER BOLT	52	2	414595	CAPSCREW 1/2-13NC X 3 1/2 HX HD GR8
29	2	418460	CLUTCH WASHER	53	1	468040	PIPE PLUG
30	1	426044	SPACER – CLUTCH	54	1	530123	GEAR BOX
31	1	426045	INSERT				

\* CC – Compact Controls (Use Part Number to match Control Valve [item #49] vendor)

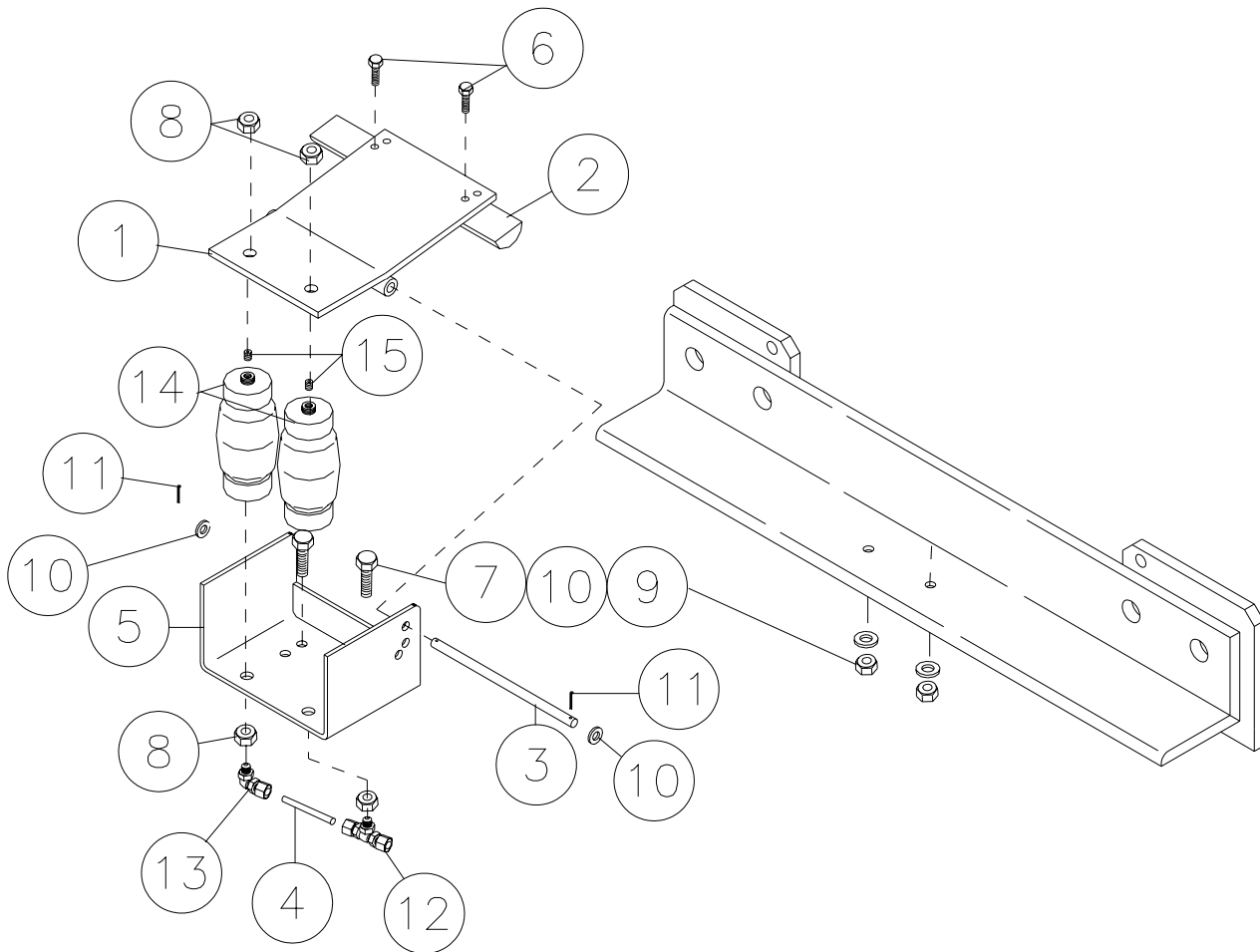

### CABLE TENSIONER (OVERWOUND) - 299704

Item No.	Qty.	Parts No.	Description
1	1	265019	TENSIONER PLATE ASSY
2	1	304167	TENSIONER BAR
3	1	346046	PIN
4	1	365038	TUBE, 1/4" DIA
5	1	408226	BRACKET ASSEMBLY
6	2	414278	CAPSCREW 3/8-16NC X 4 HX HD Z/P GR5
7	2	414548	CAPSCREW 1/2-13NC X 1-1/2 HX HD
8	4	418080	NUT 5/8-11NC REG HEX Z/P
9	2	418069	NUT 1/2-13NC HEX REG Z/P
10	2	418223	WASHER 1/2 USS A FLAT Z/P
11	2	424005	COTTER PIN 1/8 X 1
12	1	432032	FITTING
13	1	432033	FITTING
14	2	433022	AIR ACTUATOR
15	2	468016	PIPE PLUG



## LIMITED WARRANTY

RAMSEY WINCH warrants each new RAMSEY WINCH to be free from defects in material and workmanship for a period of one (1) year from date of purchase.

The obligation under this warranty, statutory or otherwise, is limited to the replacement or repair at the Manufacturer's factory, or at a point designated by the Manufacturer, of such part that shall appear to the Manufacturer, upon inspection of such part, to have been defective in material or workmanship.

This warranty does not obligate RAMSEY WINCH to bear the cost of labor or transportation charges in connection with the replacement or repair of defective parts, nor shall it apply to a product upon which repair or alterations have been made, unless authorized by Manufacturer, or for equipment misused, neglected or which has not been installed correctly.

RAMSEY WINCH shall in no event be liable for special or consequential damages. RAMSEY WINCH makes no warranty in respect to accessories such as being subject to the warranties of their respective manufacturers.

RAMSEY WINCH, whose policy is one of continuous improvement, reserves the right to improve its products through changes in design or materials as it may deem desirable without being obligated to incorporate such changes in products of prior manufacture.

If field service at the request of the Buyer is rendered and the fault is found not to be with RAMSEY WINCH's product, the Buyer shall pay the time and expense to the field representative. Bills for service, labor or other expenses that have been incurred by the Buyer without approval or authorization by RAMSEY WINCH will not be accepted.

*See warranty card for details.*



## RAMSEY WINCH COMPANY

Post Office Box 581510 Tulsa, Oklahoma 74158-1510

Telephone: (918) 438-2760 FAX: (918) 438-6688

OM-914148-0407-D